

# Pergola Aluminium 3x6M

Montageanleitung - DE

# Zusätzlich benötigte Werkzeuge und Sicherheitskleidung für die Installation (nicht enthalten)

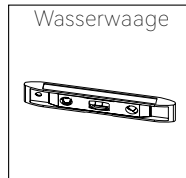
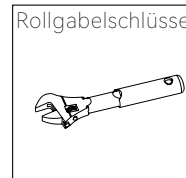
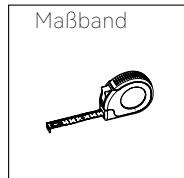
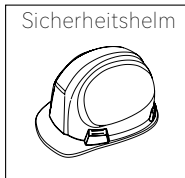
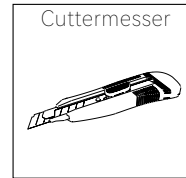
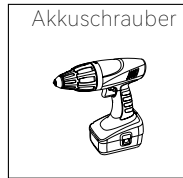
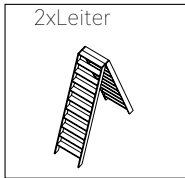

## 2D Fundamentmessung (Dimension in mm)

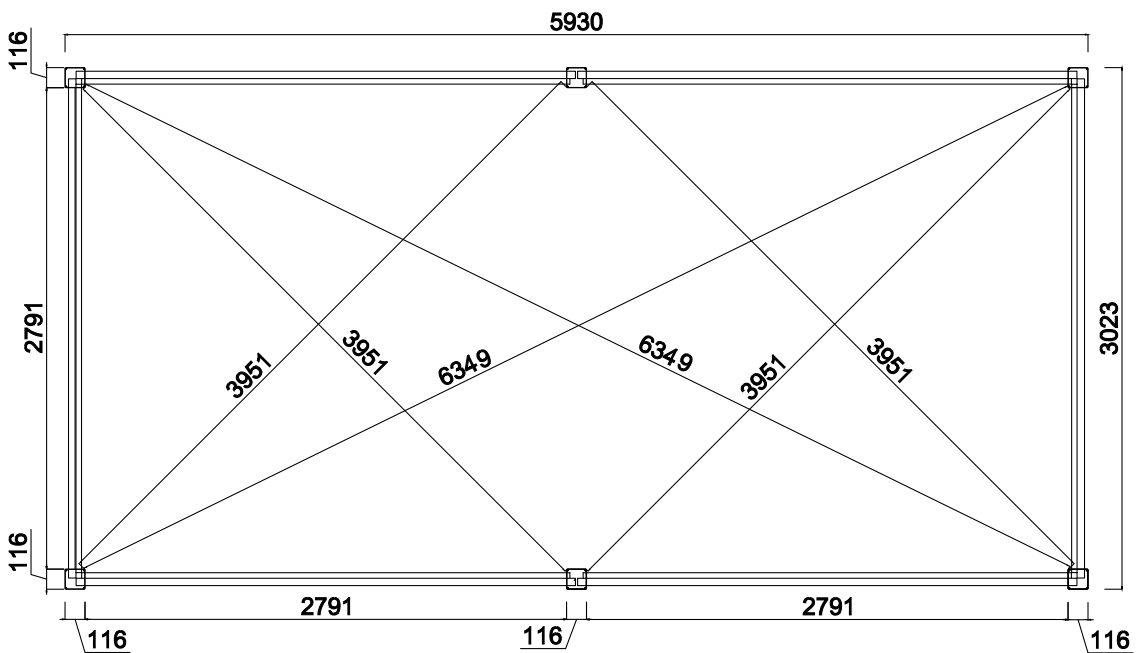

## 3D Fundamentmessung (Dimension in mm)

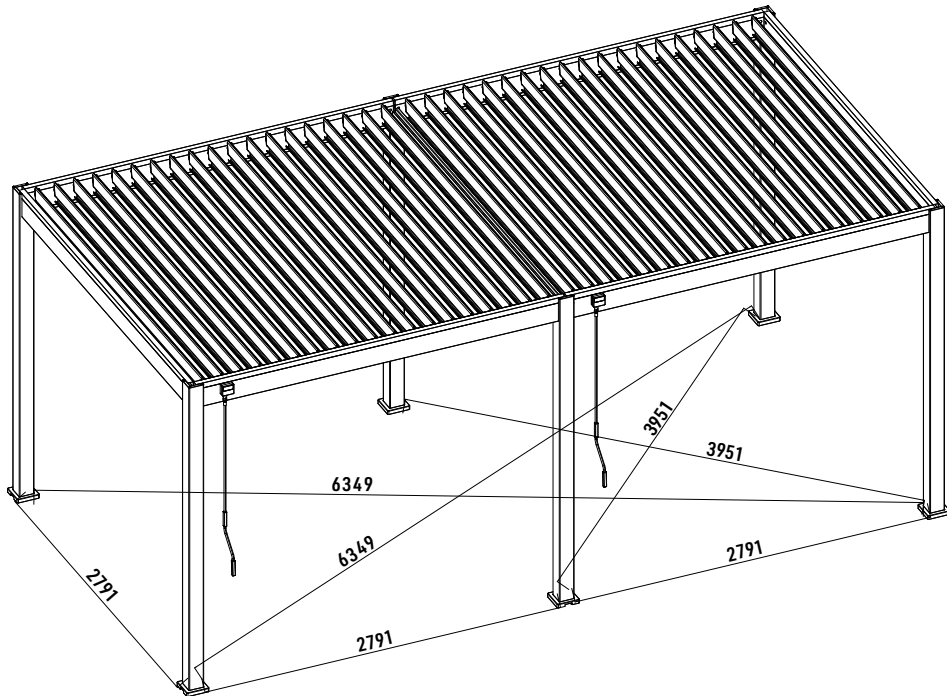

## WARNHINWEISE FÜR DEN GEBRAUCH

Dieses Produkt sollte nicht bei extremen Wetterbedingungen wie Stürmen, starkem Wind, Hagel oder Schnee verwendet werden. Wir garantieren die Beständigkeit der Pergola für Windgeschwindigkeiten bis zu 100 km/h und eine maximale Schneelast von 50 kg/m<sup>2</sup>.

Bei starkem Schneefall oder Wind öffnen Sie bitte die Lamellen, um mögliche Schäden zu vermeiden.

Entfernen Sie den Schnee regelmäßig vom Dach, um eine Überlastung des Daches zu verhindern.

Unsere Pergola kann starke Regenfälle standhalten, es kann jedoch keine vollständige Wasserdichtigkeit garantiert werden. Bei außergewöhnlichen Wetterereignissen kann die Wasserdichtigkeit beeinträchtigt werden. Lassen Sie keine feuchtigkeitsempfindlichen Produkte unter der Pergola stehen

Wir raten davon ab, auf das Dach oder das Gestell der Pergola zu klettern. Es besteht die Gefahr von Schäden und Verletzungen.

## Tipps und Sicherheitshinweise

Je nach Standort und Fläche kann es sein, dass für den Bau eine Baugenehmigung oder ein Antrag auf Baugenehmigung erforderlich ist. Wir empfehlen Ihnen, sich vor dem Aufbau an Ihre Stadtverwaltung zu wenden, um die entsprechenden Informationen zu erhalten.

Produktmontage:

- Es werden 2-3 Personen benötigt
- Entfernen Sie vor der Installation die Schutzfolie von allen Teilen
- Lassen Sie Kinder nicht in der Nähe des Montagebereichs spielen
- Achten Sie auf die Klemmgefahr
- Ziehen Sie die Schrauben nicht vollständig an, bevor Sie die entsprechenden Teile zusammen gebaut haben
- Alle Aufbauschnitte müssen genau befolgt werden
- Diagonalen und Auslotungen kontrollieren
- Befestigen Sie die Pergola erst nach dem Zusammenbau

Es dürfen keine Veränderungen am Produkt vorgenommen werden. Vom Benutzer abgeänderte Produkte, fallen nicht mehr unter die Garantie des Herstellers.

Der Standort sollte mit Bedacht gewählt sein. Es wird empfohlen die Pergola nicht bei Regen, in der Hauptwindrichtung oder unter einem Baum aufzustellen.

Die Pergola muss auf einem ausreichend stabilen und ebenen Fundament errichtet werden. Es wird empfohlen sie auf einer Betonplatte oder auf 25 x 25 cm großen Betonklötzen an jedem Pfosten zu errichten.

Wenn Sie ihre Pergola in der Nähe des Hauses oder eines Gebäudes aufstellen möchten, achten Sie darauf, dass Regenrinnen vorhanden sind, damit Regenwasser abfließen kann. Die Pergola ist nicht dafür ausgelegt, Wasser aufzunehmen, das von Ihrem Haus in sie hineinläuft.

Falls diese Hinweise nicht oder nur teilweise befolgt werden, erlischt die Garantie des Verkäufers.

## Wartung

Eine regelmäßige Pflege des Produkts ist nötig, um eine Langlebigkeit des Produkts zu gewährleisten.

Empfehlungen:

- Reinigen Sie die Pergola 1-2-mal im Jahr mit Süßwasser und einem Schwamm oder Tuch. Verwenden Sie keine aggressiven Reinigungs- oder Scheuermittel.
- Überprüfen Sie regelmäßig (min 1x im Jahr) ob die Schrauben fest angezogen sind.
- Ölen Sie die Befestigungen regelmäßig (mindesten 1x pro Jahr)
- Achten Sie darauf, dass nichts den Wasserabfluss in den Regenrinnen behindert (Blätter, Äste)
- Entfernen Sie Wasser, das sich an den Füßen der Pergola herum sammelt (heben Sie die Abdeckungen an)

# Garantie

Die Garantie umfasst nicht:

- Normale Gebrauchsspuren des Produkts
- Verlust oder Bruch von Teilen beim Auspacken oder bei der Montage
- Mangel an vernünftiger Sorgfalt, Vernachlässigung, Vandalismus, Einwirkung
- Schäden durch Fremdkörper, Gewaltanwendung, Kontakt mit Schleifmitteln oder ästhetische Beeinträchtigungen
- Ausbau, Wiederaufbau oder Verlegung des Standorts.
- Höhere Gewalt: Hagel, starke Winde, Stürme, Schnee, Überschwemmungen,
- Blitzschlag...
- Veränderung des Produkts durch den Benutzer.

Die Garantie umfasst nur den Ersatz des Ersatzteils oder des gelieferten Produktes, unter Ausschluss jeglicher Kosten und Entschädigungen jeglicher Art.

Die Garantie muss bei der Verkaufsstelle (Geschäft oder Internetseite) beantragt werden, bei der Sie Ihr Produkt gekauft haben.

## Teileliste pro Karton

Bevor Sie mit dem Aufbau beginnen, bitten wir Sie alle aufgeführten Bauteile auf Vollständigkeit zu prüfen. Zudem bitten wir Sie nachzuschauen, dass keine Schäden an den Teilen vorhanden sind. Fehlende oder beschädigte Teile müssen binnen 10 Werktagen nach Anlieferung beim Hersteller reklamiert werden.



Sie können hierzu gerne unseren Kundenservice kontaktieren.



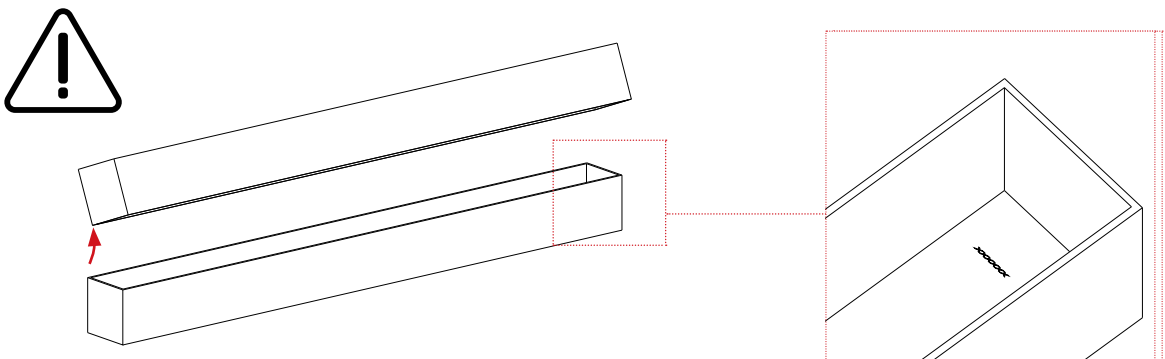





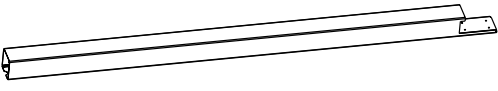

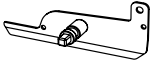

Entsorgen Sie die Verpackung nicht, ohne sicherzustellen, dass das Produkt richtig funktioniert.

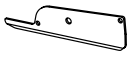

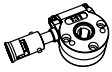











Auf der Innenseite des Kartons befindet sich eine Produktverfolgungsnummer (siehe Abbildung unten). Für einen besseren und effizienteren Kundendienst in der Zukunft machen Sie bitte ein Foto der Tracking-Nummer, bevor Sie den Karton entsorgen, und speichern Sie dieses

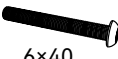



# KARTON 1/5



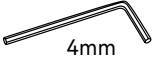

Nr.	Profil	Bild	Maße	Menge
AO			116X116 L=2550mm	4
AO-1			116X116 L=2550mm	2

Nr.	Bild	Menge
IO		6
JO		6
KO		2
LO		36
LO-1		38
EO-1		2
MO		74
NO		2
OO		2
PO		2
QO	  6mm	24
RO		24
SO		76

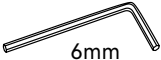

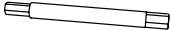







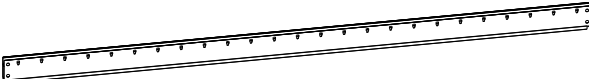

Nr.	Bild	Menge
TO	 10x80	24
UO	 lock nut	112
WO	  4x16 PH2	152
WO-1	  5x19 8mm	6
XO	  6x40 4mm	74
XO-1	  6x35 4mm	24
XO-3	  6x16 4mm	4
VO		38
YO	  6x45 4mm	6

## KARTON 1/5

Nr.	Bild	Menge
ZO-1	 4mm	1
ZO-2	 4mm	1
ZO-3	 6mm	1

Nr.	Bild	Menge
ZO-4	 6mm	1
ZO-5	 10mm	1
ZO-6	 PH2	1
ZO-7	 8mm	1

## KARTON 2/5

Nr.	Profil	Bild	Maße	Menge
BO			75X153 L=3809mm	2
BO-1			75X153 L=3809mm	2
CO			95X153 L=2894mm	2
EO			111X64 L=2855mm	1
DO			42X54 L=3809mm	2
FO			27X8 L=2744mm	2
HO			L=1300mm	2





**ATTENTION!**

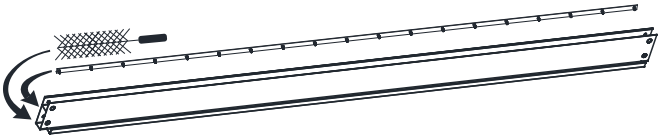

Verbindungsstangen (FO) und Bürste innen!





## KARTON 3/5

Nr.	Profil	Bild	Maße	Menge
GO			166X30 L=2855mm	13

## KARTON 4/5

Nr.	Profil	Bild	Maße	Menge
GO			166X30 L=2855mm	13

## KARTON 5/5

Nr.	Profil	Bild	Maße	Menge
GO			166X30 L=2855mm	12

## Montageanleitung

Schritt 1: Rahmen





Schritt 2: Lamellen

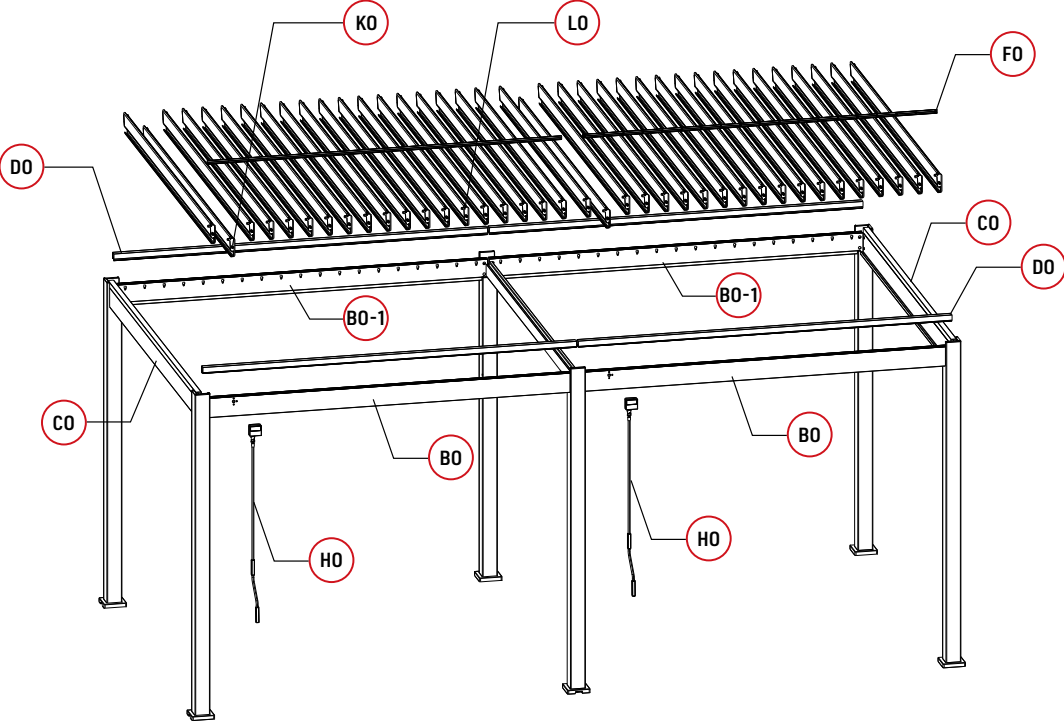

Schritt 3: Verbindungen

# MONTAGEBILD



1

AO		4
IO		4
JO		4
XO-1	 6x35  4mm	16

ZO-1	 4mm	1
ZO-2	 4mm	1

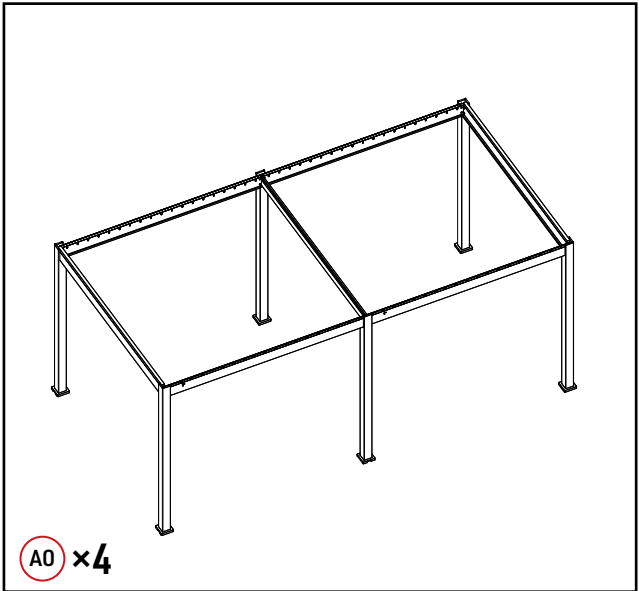

AO x4



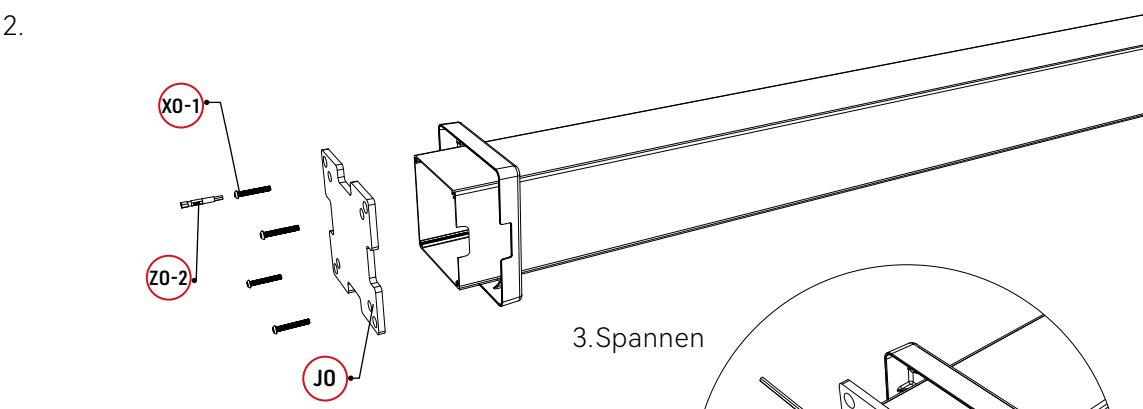
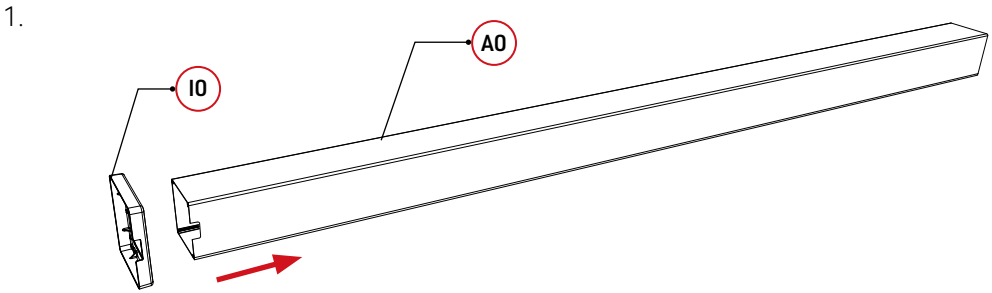

Diagramm zur Fertigstellung.

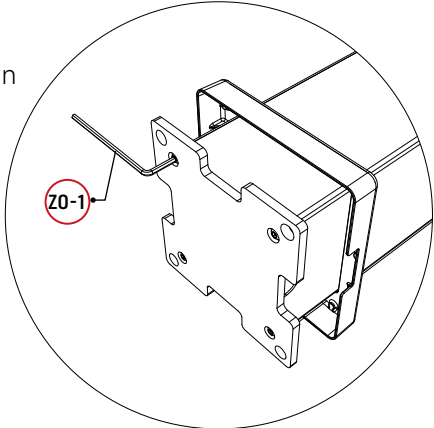



3. Spannen



1

AO-1		2
IO		2
JO		2
XO-1	 $\phi \times 35$ 4mm	8

ZO-1	 4mm	1
ZO-2	 4mm	1

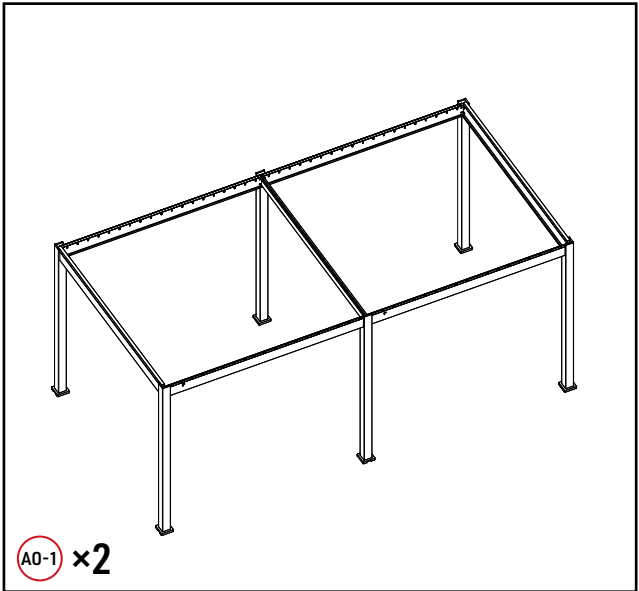

AO-1 x2

Diagramm zur Fertigstellung.

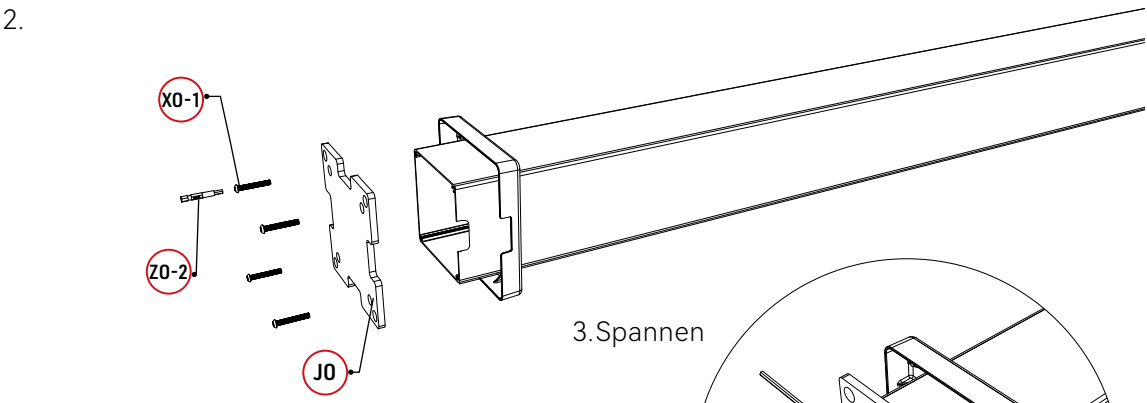
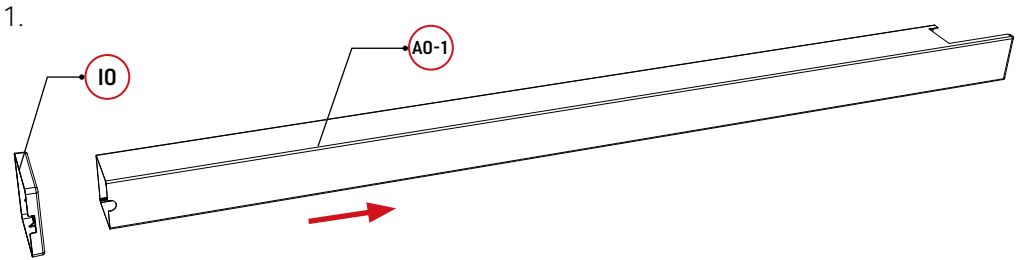

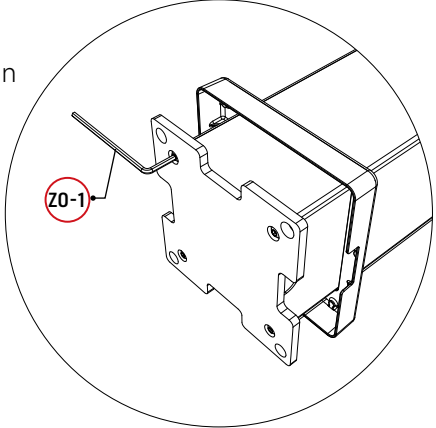

3. Spannen



1

CO		2
----	---	---

QO		8
----	---	---

ZO-3		1
ZO-4		1

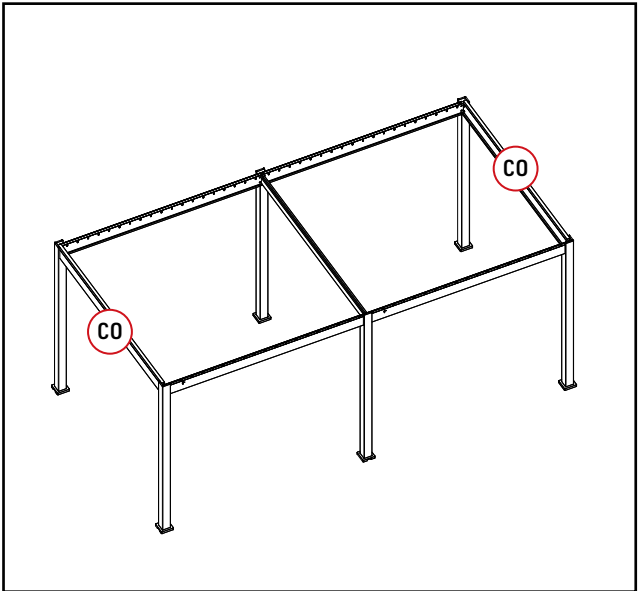

Balken mit Pfosten verbinden.

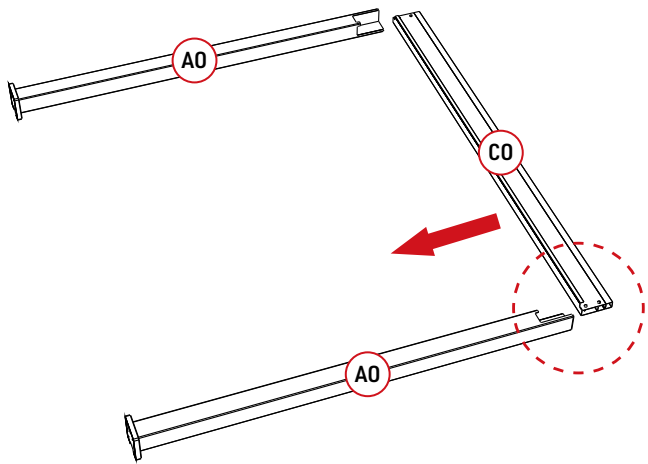

1.

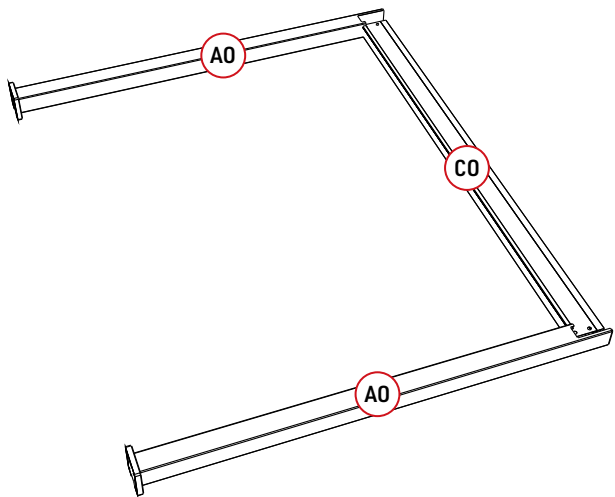
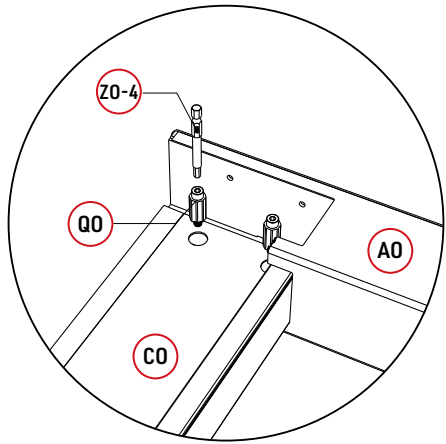

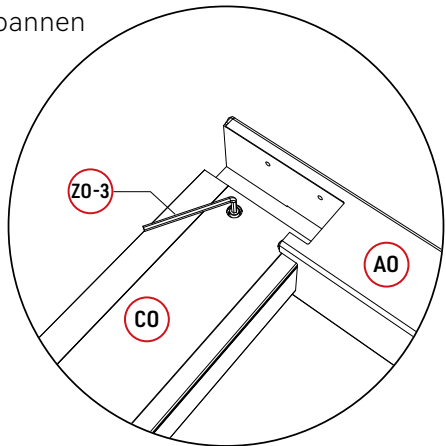

2. Spannen

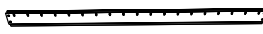

1

BO		2
BO-1		2

QO		16
----	---	----

ZO-3		1
ZO-4		1

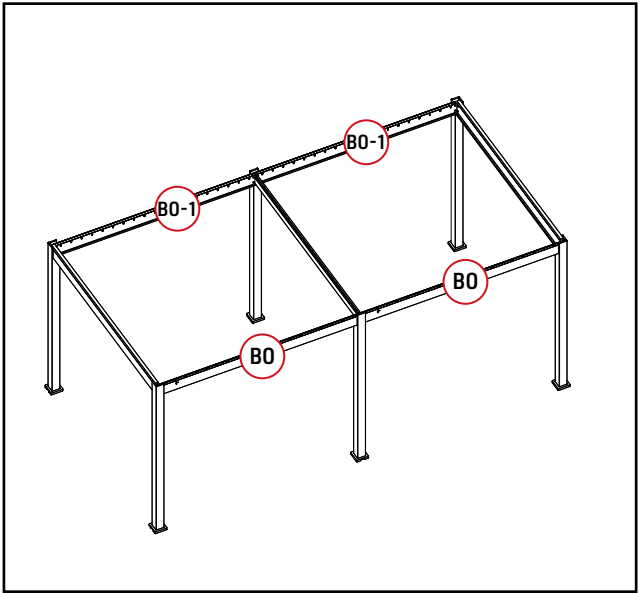

Balken mit Pfosten verbinden.

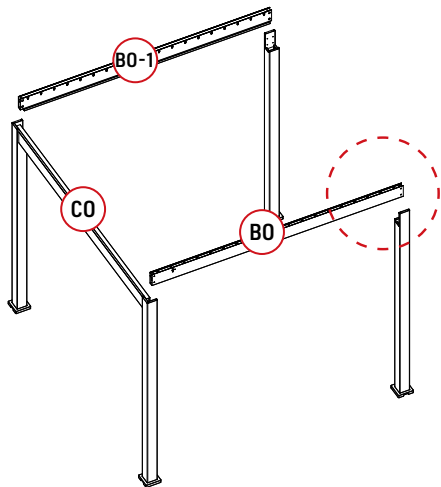
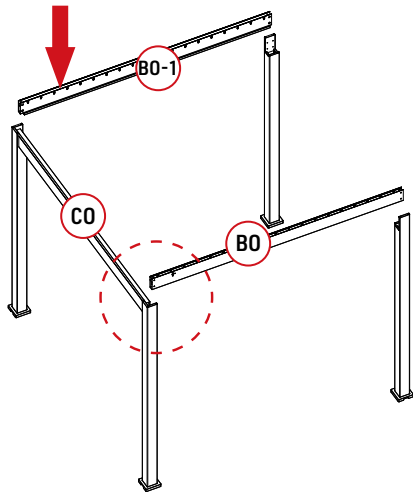

1.

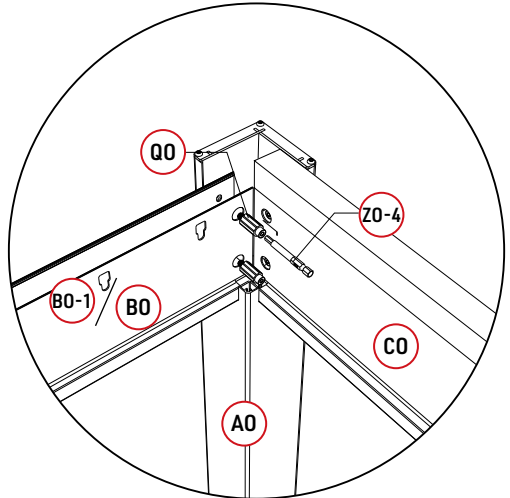

2.

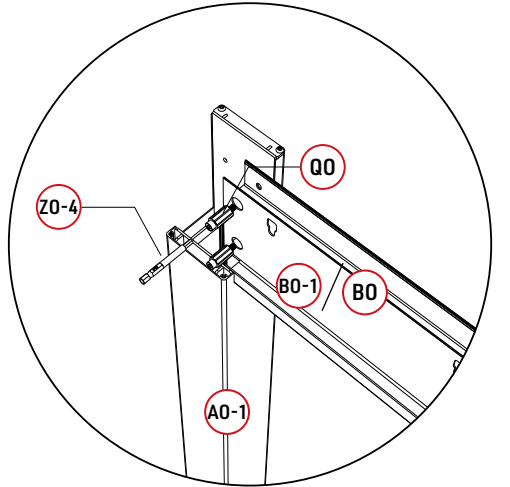

1

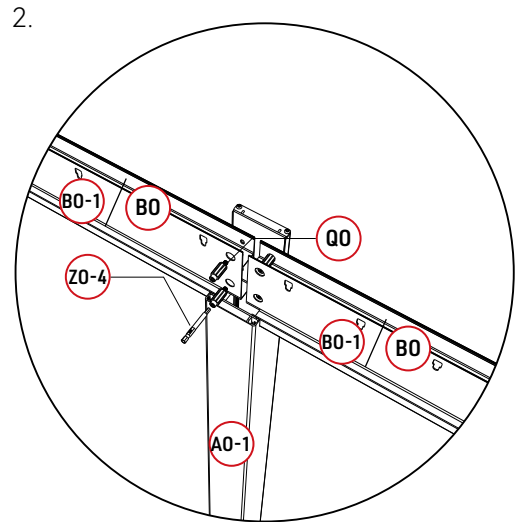
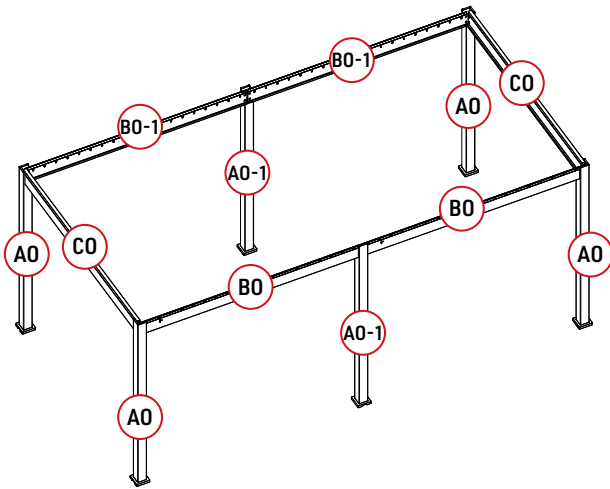
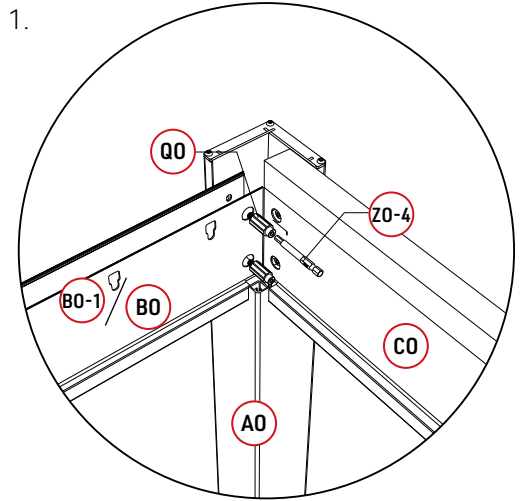
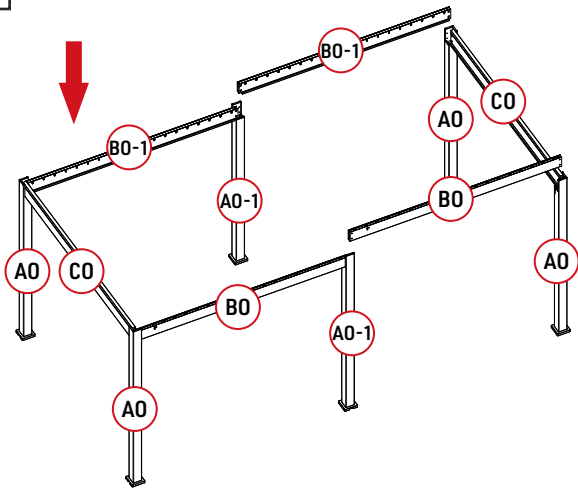

Spannen

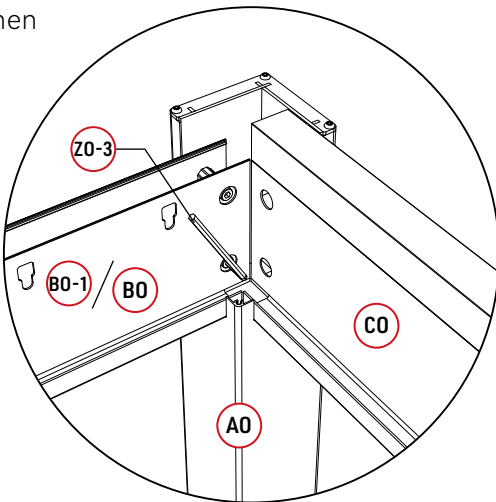



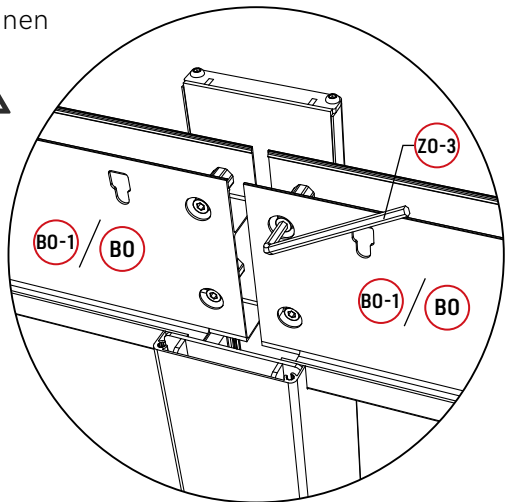





Spannen



1

EO		1
----	---	---

EO-1		2
WO-1	 	6
XO-3	 	4

ZO-1		1
ZO-2		1
ZO-7		1

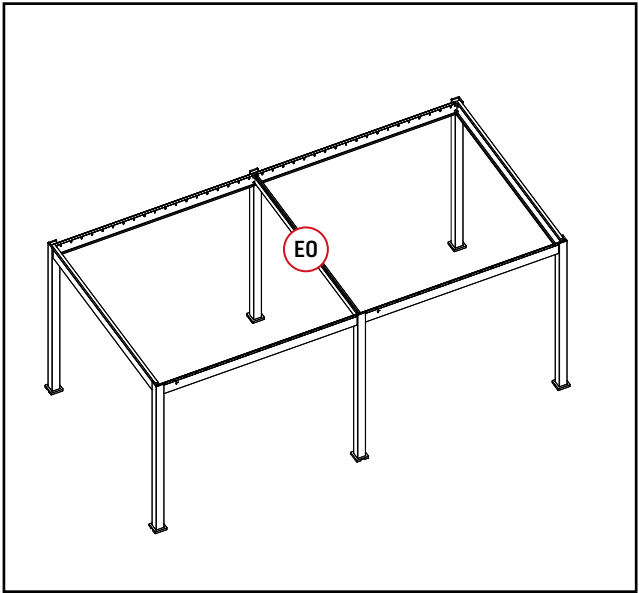



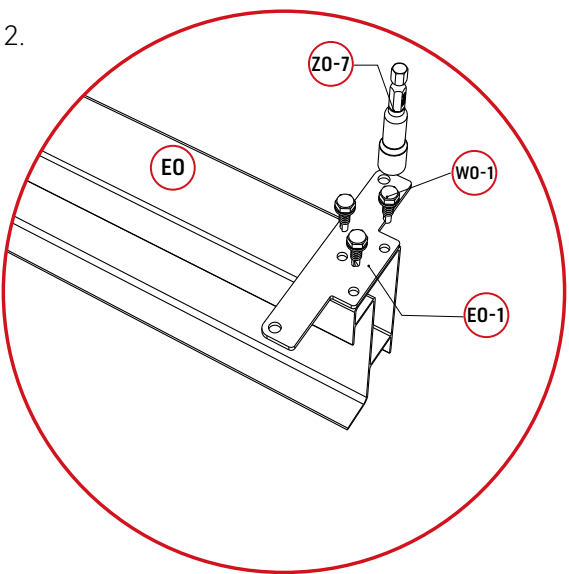
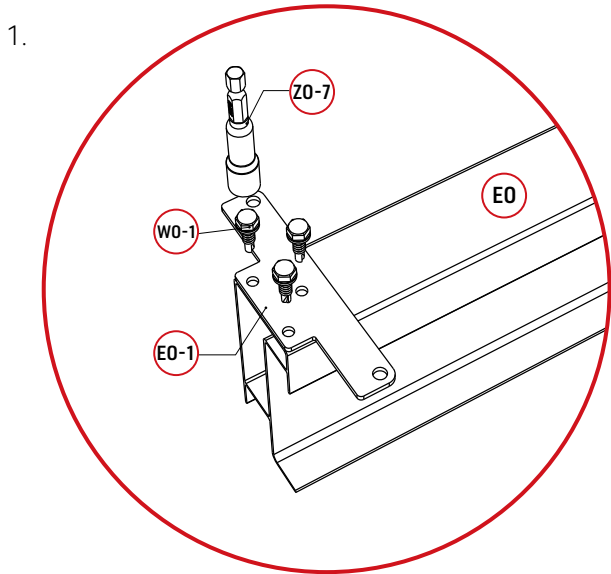
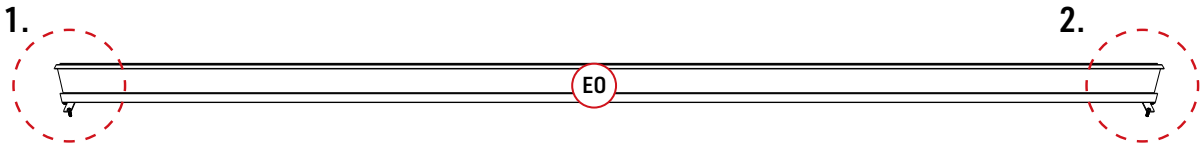

Balken mit Pfosten verbinden.

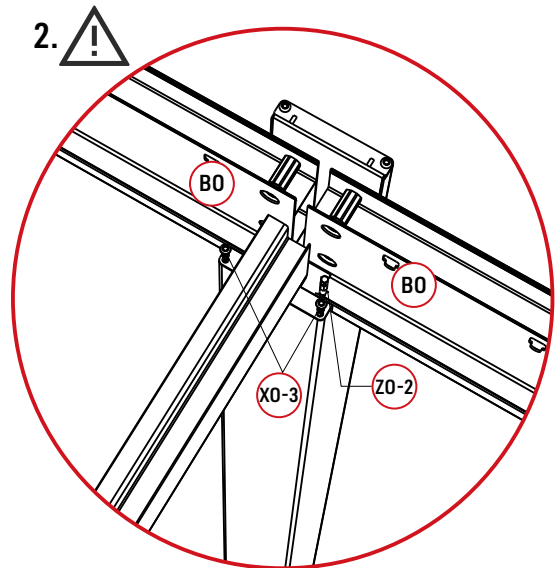
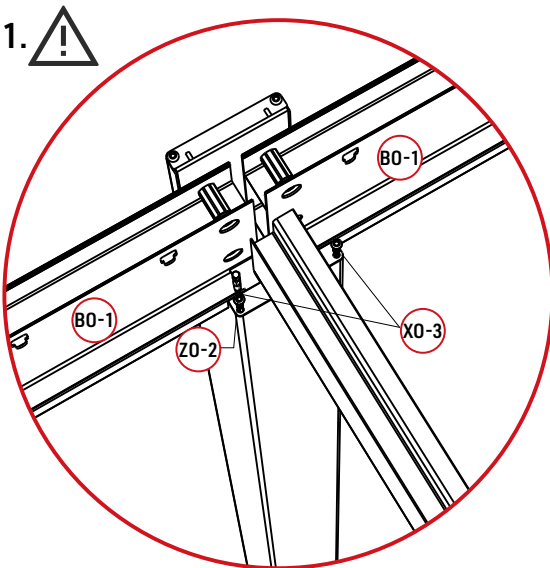
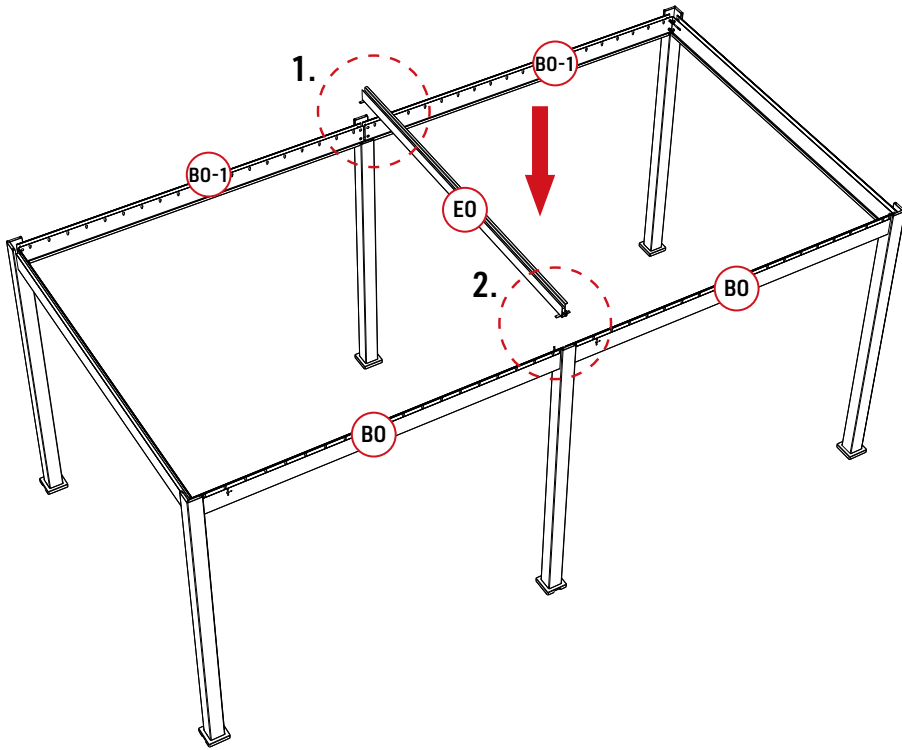



1



2

LO		36	XO		74
LO-1		38	UO		74
MO		74			

ZO-3		1
ZO-4		1

Die Abbildung zeigt einen manuellen Schraubenschlüssel, der durch einen elektrischen P-Bit ersetzt werden kann.

Montieren Sie die Antriebe für die Lamellenabdeckung auf beiden Seiten der Lamellen.  
Hinweis: Um ein Brechen der Kunststoffteile (MO) zu vermeiden, verringern Sie bitte die Drehkraft des Akkuschraubers, wenn Sie ihn verwenden.

LO ×36

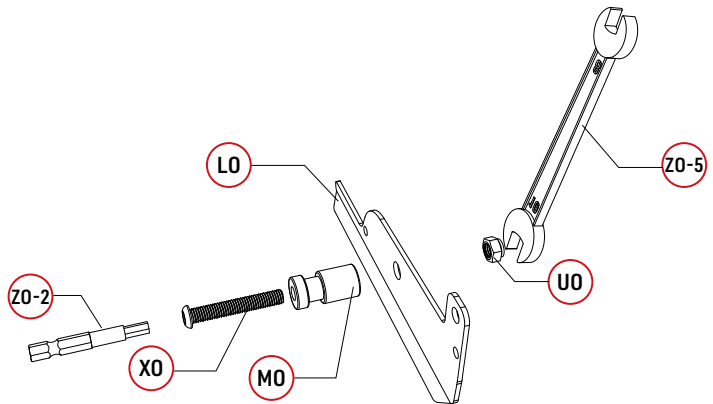
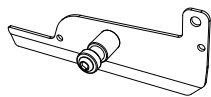



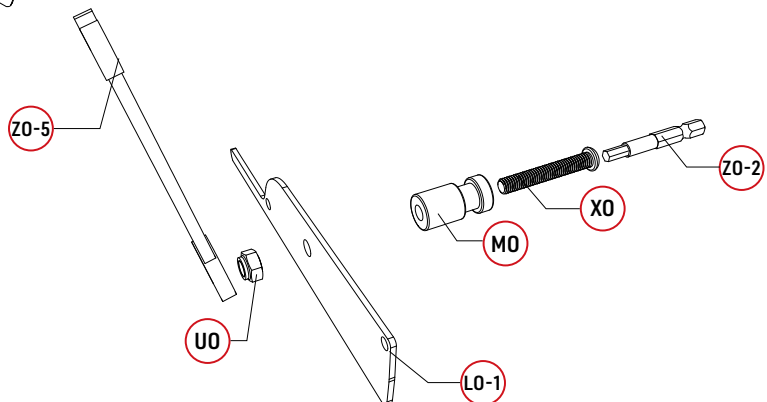
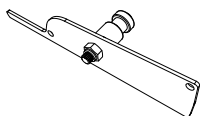

Montieren Sie die Antriebe für die Lamellenabdeckung auf beiden Seiten der Lamellen.



LO ×38



2

GO		38
----	---	----

KO		2
LO		36
LO-1		38
WO		152

ZO-1		1
ZO-2		1
ZO-6		1

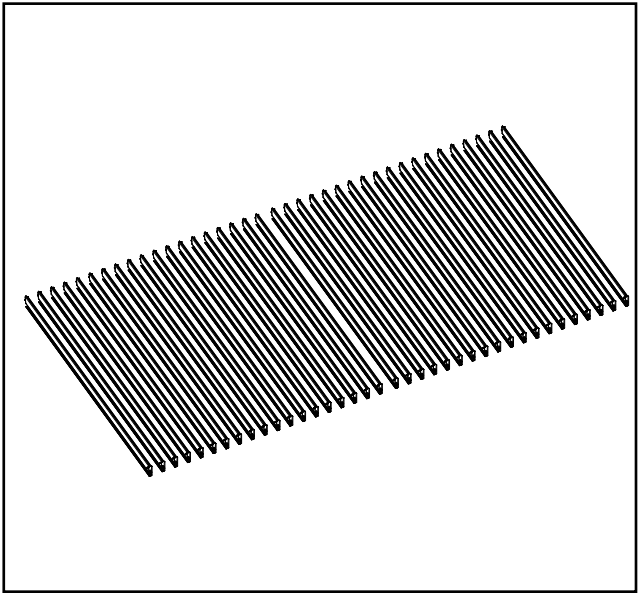

Anschluss der Lamellen.

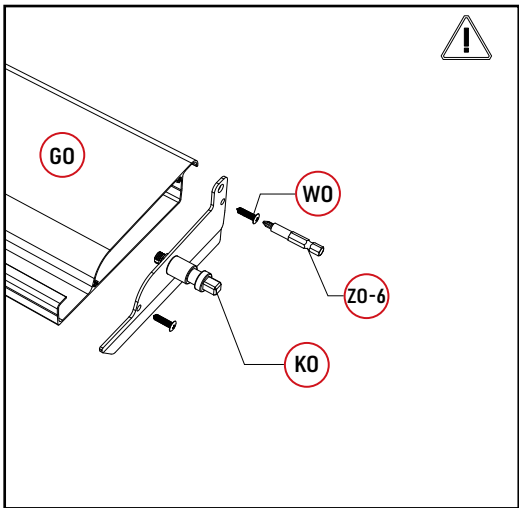
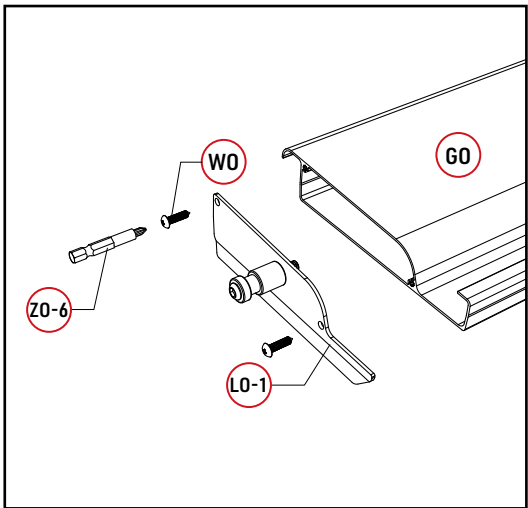
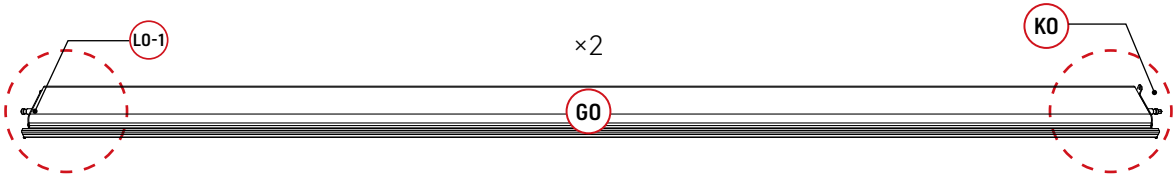

2

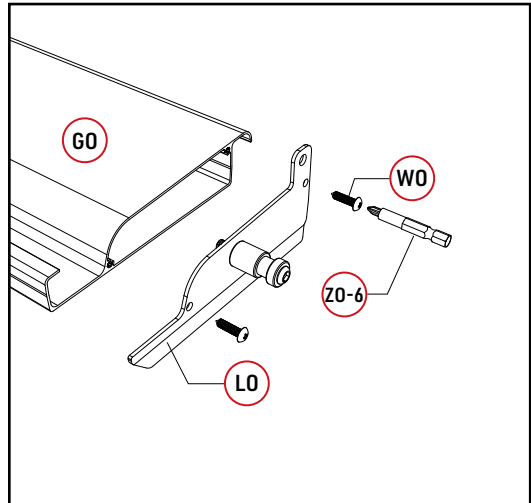
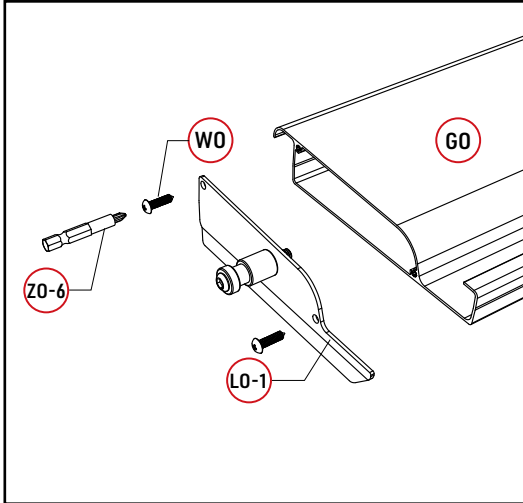
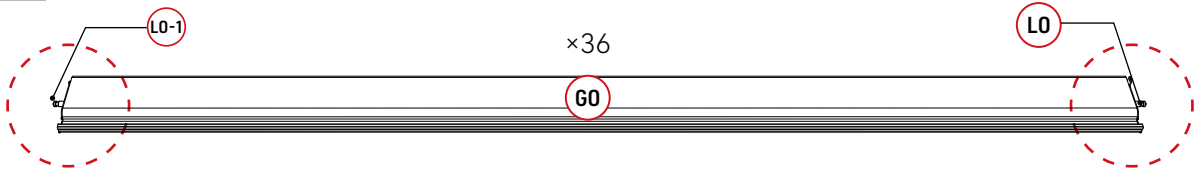

3

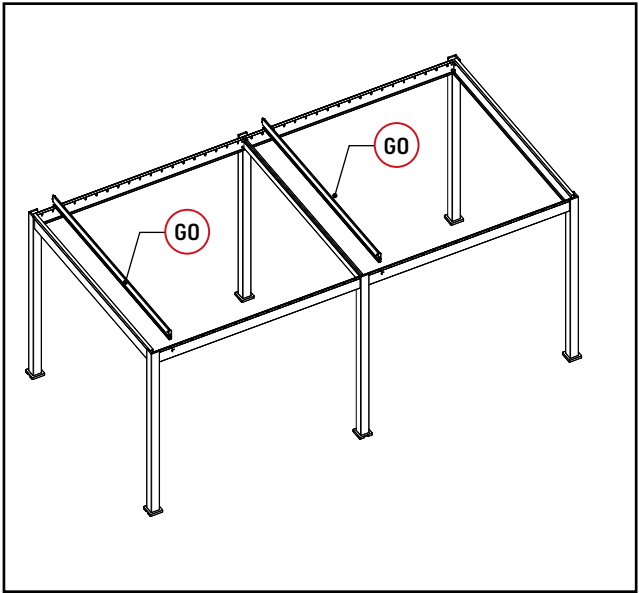

Befestigen Sie die Gummistopfen an beiden Enden der Lamellen.

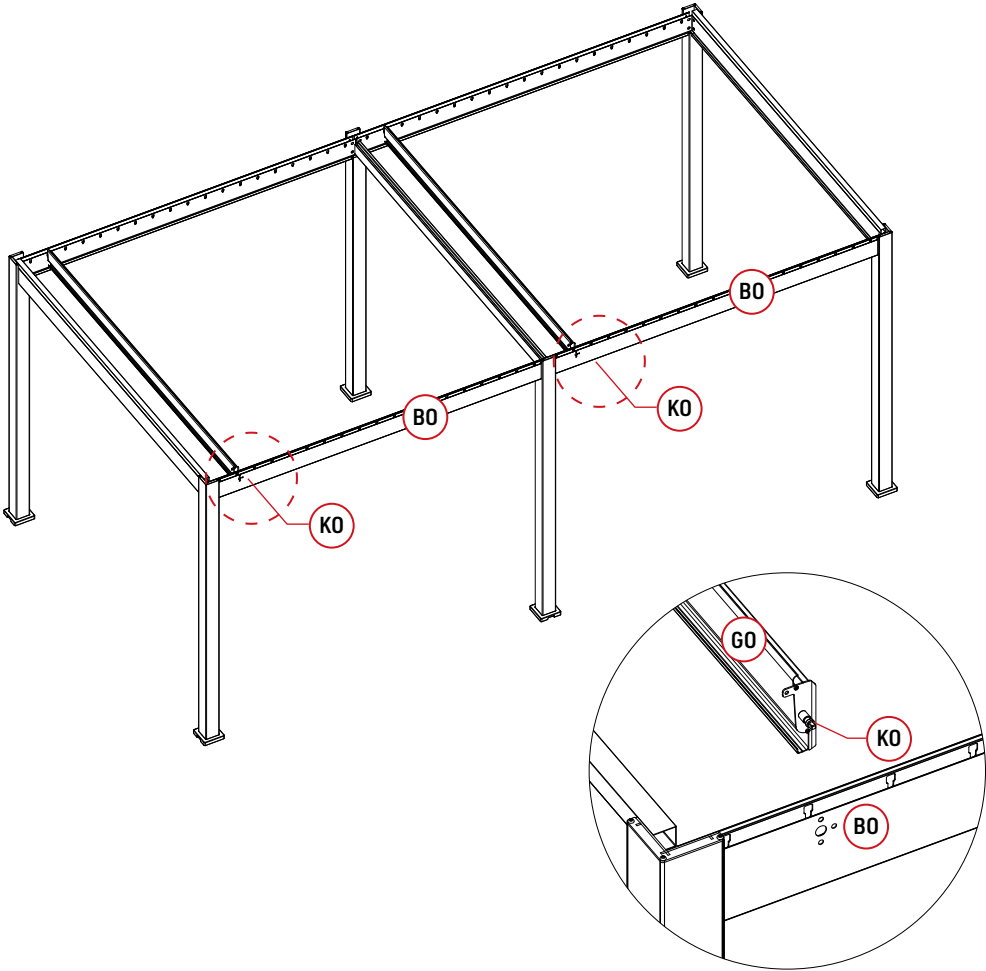

3

1

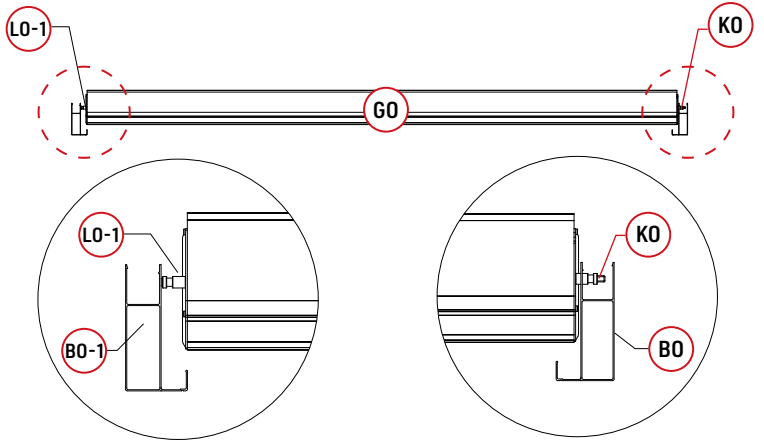
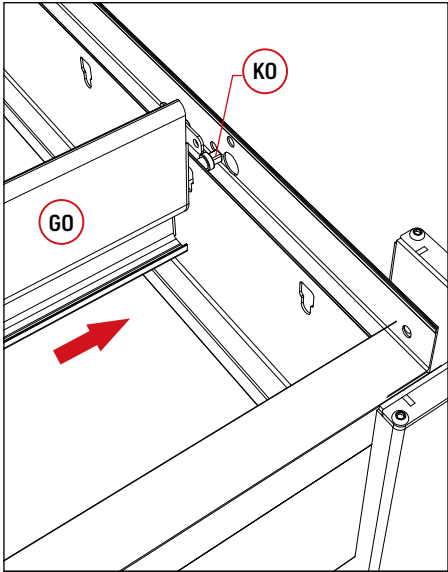

2

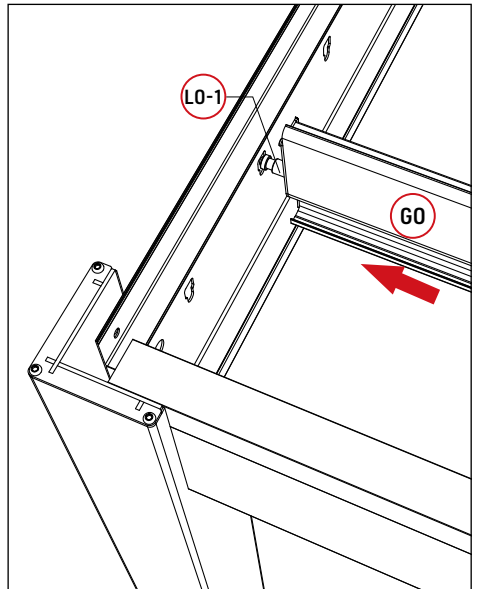
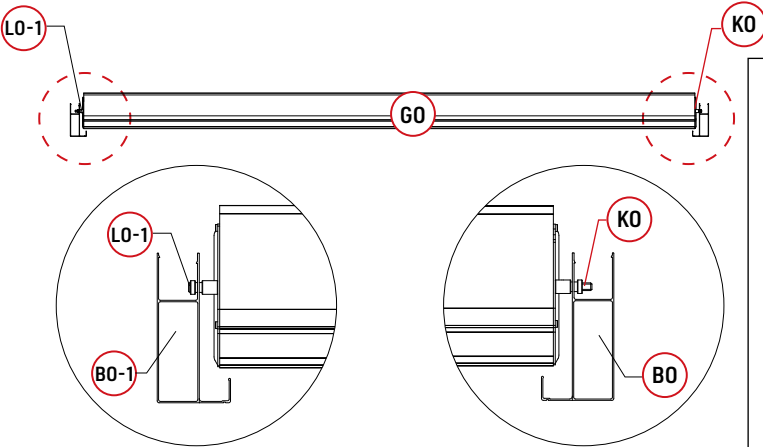

3

SO		76
----	---	----

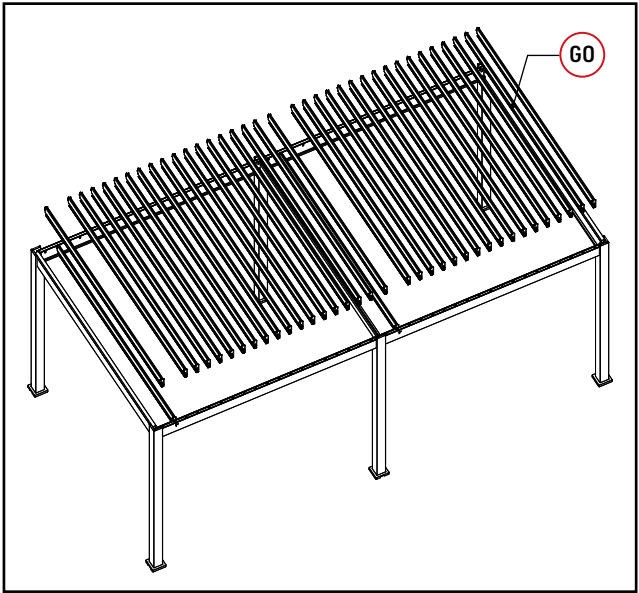

Setzen Sie die anderen Lamellen ein und verschließen Sie die Endkappen.



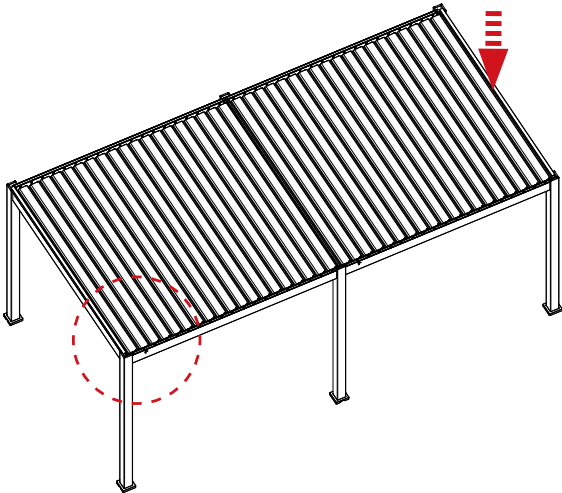

1

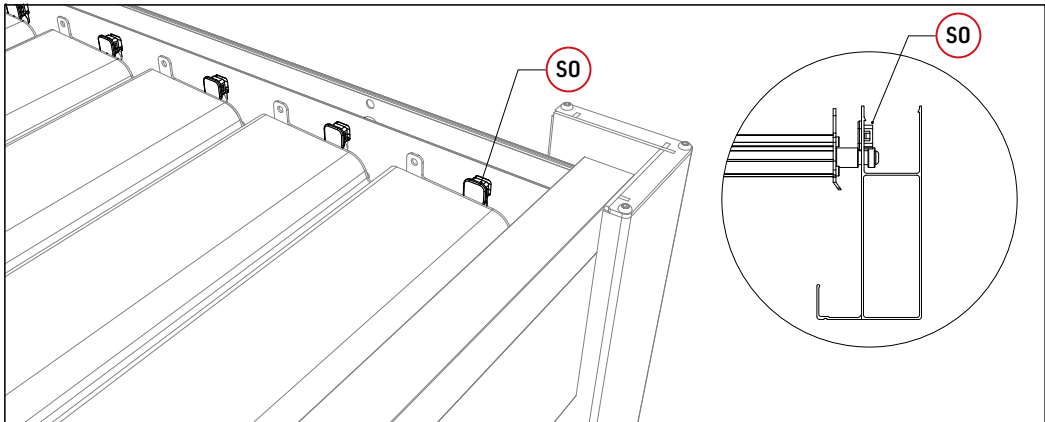



2

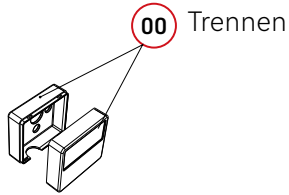

3

HO		2
NO		2
OO		2
PO		2
YO		6



ZO-1		1
ZO-2		1

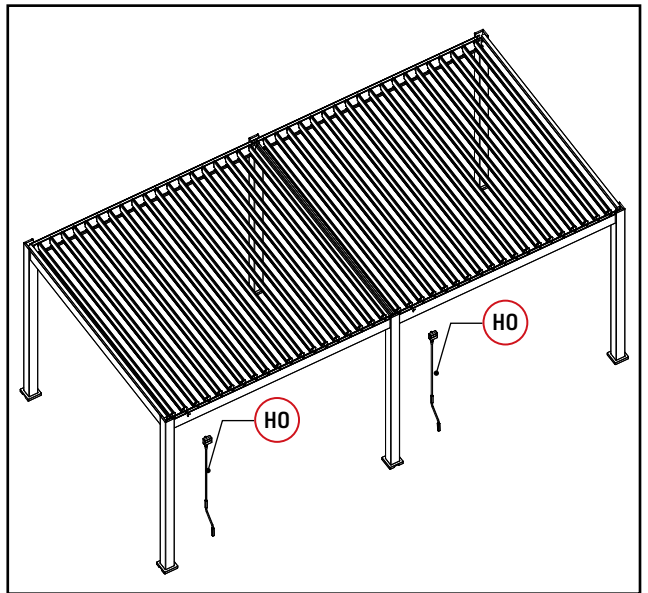

Schließen Sie die Verbindung der Lamellen ab.

1

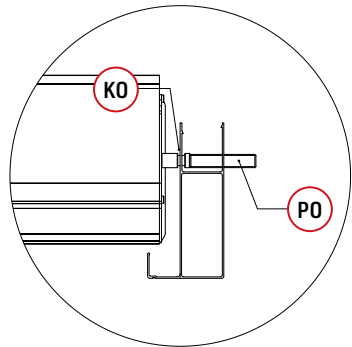
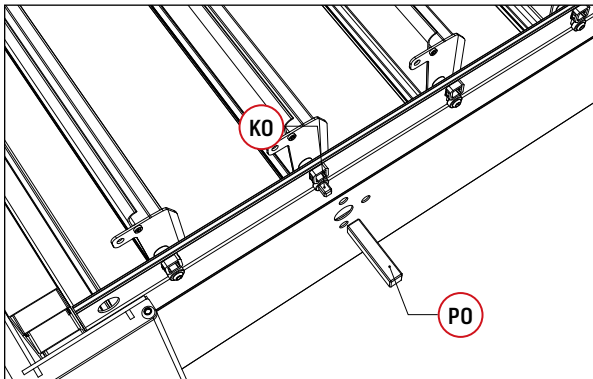

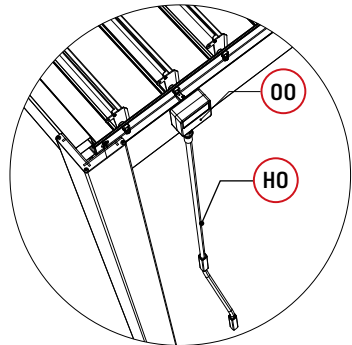
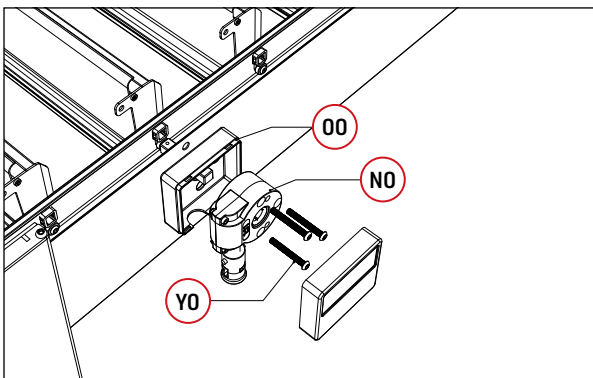

2



3

FO		2
----	---	---

VO		38
UO		38

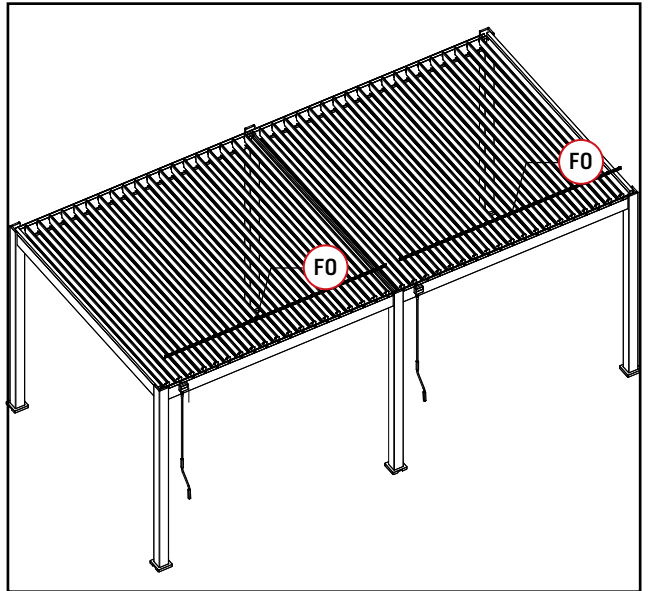

ZO-1		1
ZO-2		1
ZO-5		1

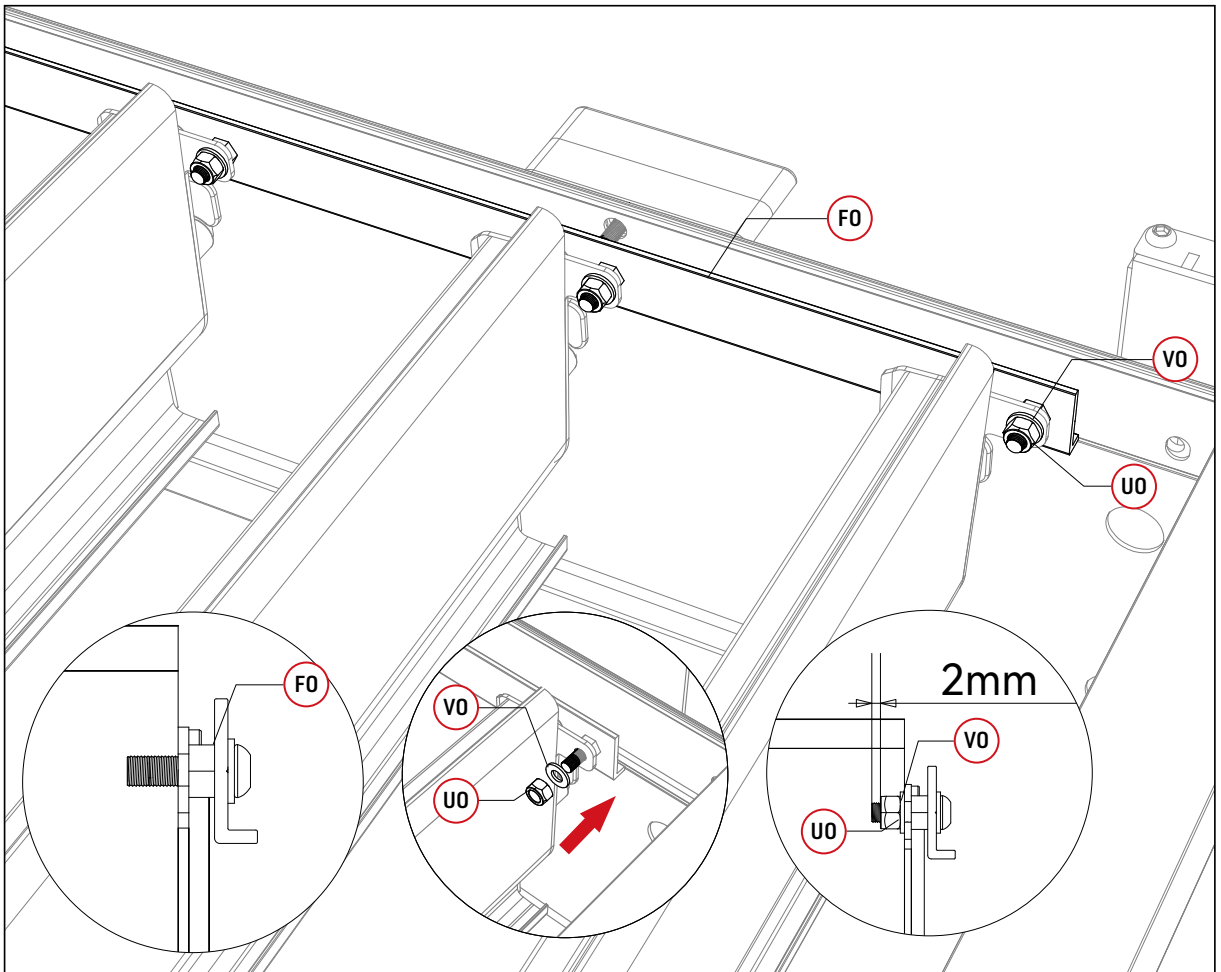

Schließen Sie die Verbindung der Lamellen mit dem FO-Teil ab.



3

DO			4
RO		24	
TO		24	

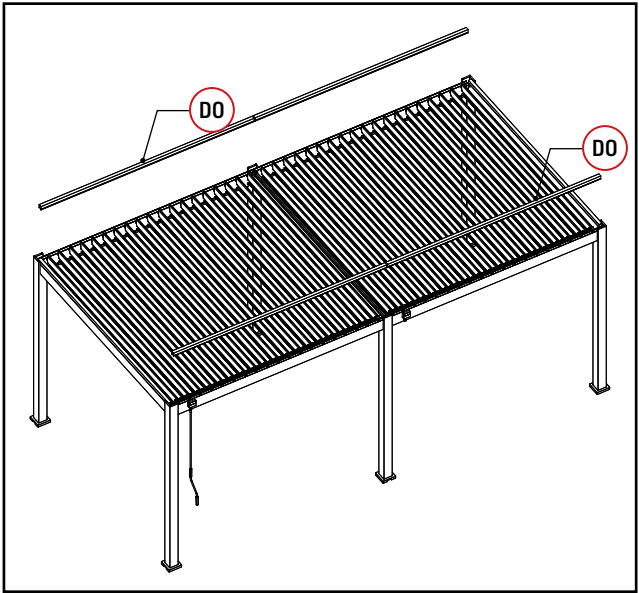

Schließen Sie die Abdeckung, um die Befestigung der Pergola zu beenden.

1

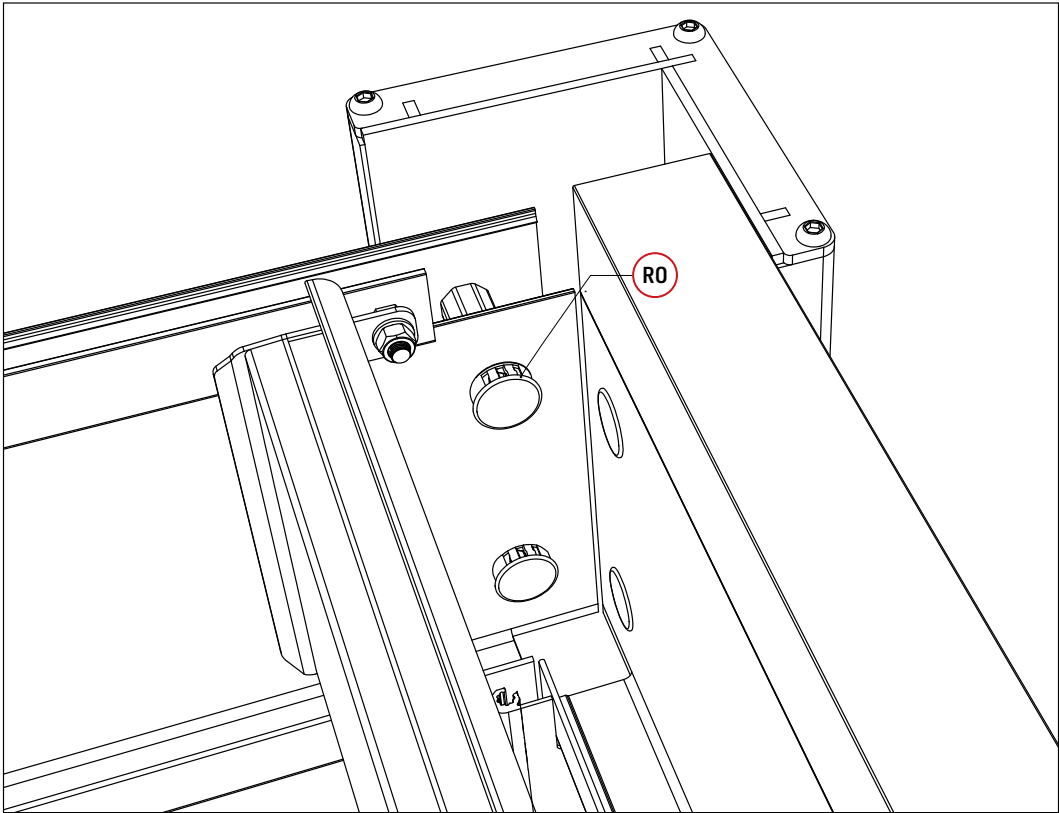

2

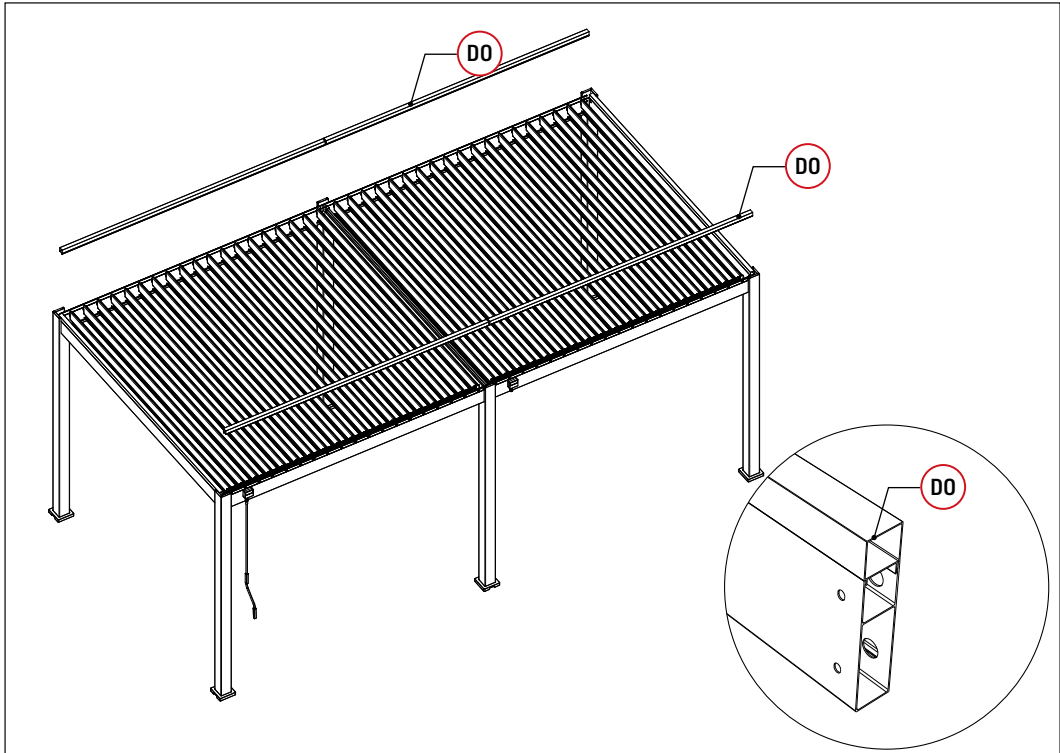

Nach Überprüfung der Maße die Dehnschrauben auf der Platte befestigen.

3

