

4x6 Meter Wand Pergola Aluminium

Montageanleitung - DE

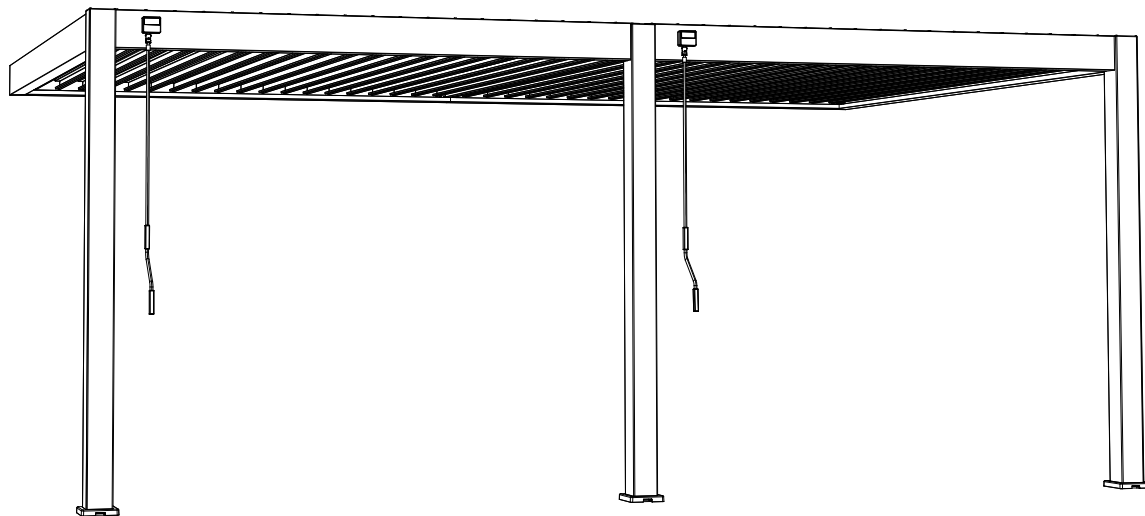

Deluxe Aluminium Wand Pergola 4x6 Meter

Bewahren Sie die Anleitung während der gesamten Lebensdauer des Produkts auf. Bitte lesen Sie die Anleitung vor dem Zusammenbau aufmerksam durch. Der Nutzer haftet für Schäden oder Verletzungen, die durch unsachgemäße Verwendung verursacht werden.

Zusätzlich benötigte Werkzeuge und Sicherheitskleidung für die Installation (nicht enthalten)



Sicherheitsbrille
und
Arbeitshandschuhe



2x Leiter



Bohrmaschine
+ 12 mm Bohrer



Akkuschrauber

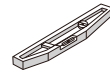

Wasserwaage



Cuttermesser



Sicherheitshelm

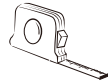

Maßband



Kleber

2D Fundamentmessung (Dimension in mm)

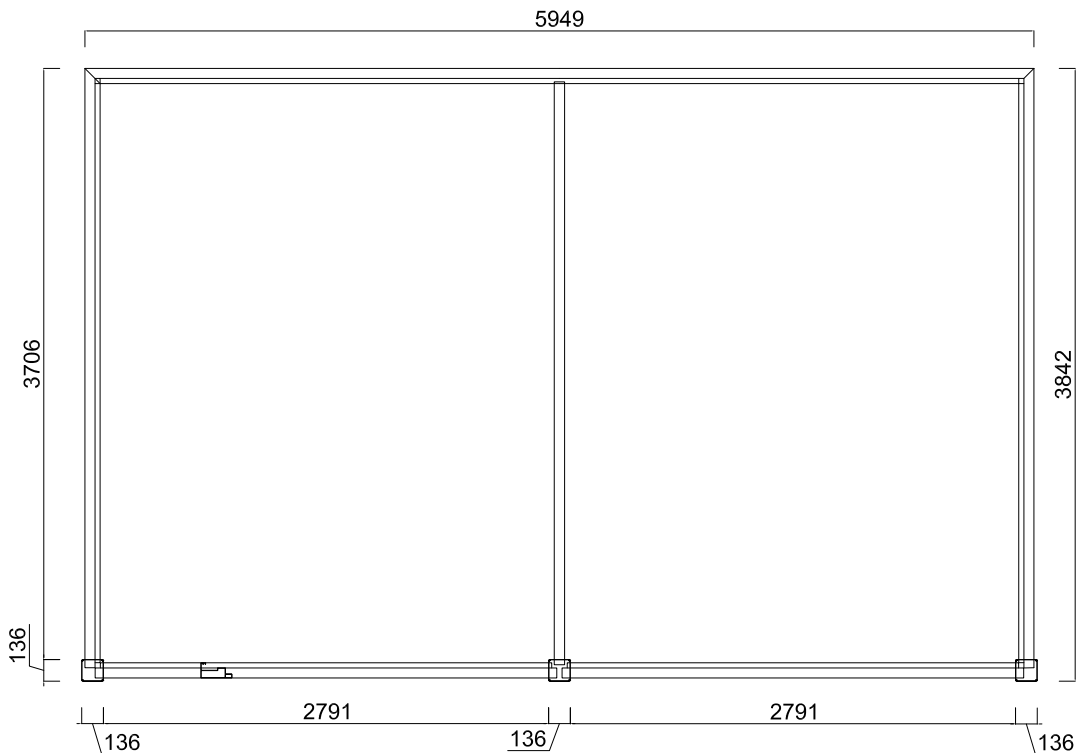

3D-Fundamentmessung (Dimension in mm)

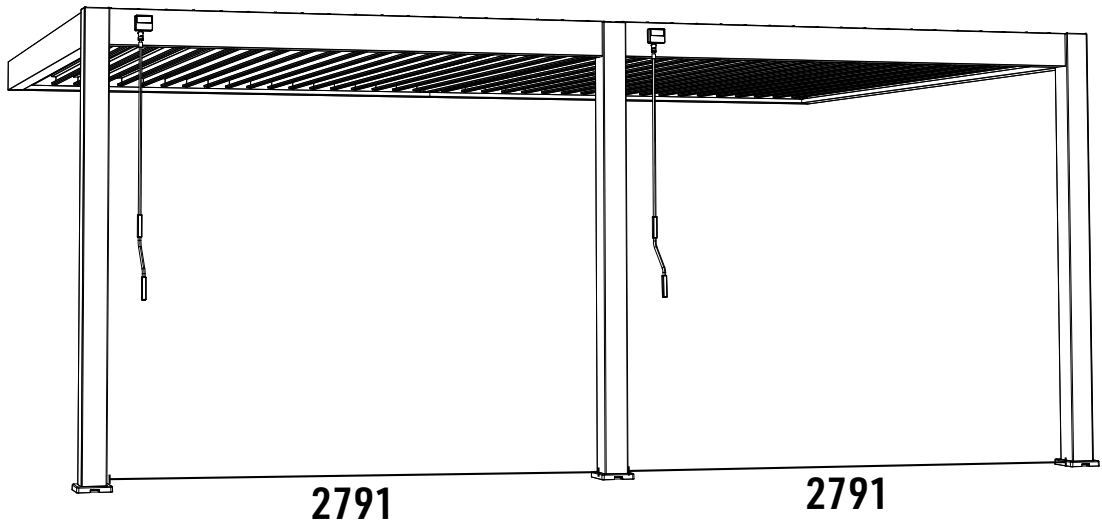

VORSICHTSHINWEISE FÜR DEN GEBRAUCH

Dieses Produkt sollte nicht bei extremen Wetterbedingungen verwendet werden: Stürme, heftiger Wind, Hagel und Schnee. Wir garantieren die Beständigkeit der Pergola für Windgeschwindigkeiten bis zu 100 km/h und eine maximale Schneelast von 50 kg/m².

Bei starkem Schneefall oder Wind, weisen wir ausdrücklich darauf hin die Lamellen zu öffnen. Bitte nicht vergessen, den Schnee vom Dach zu entfernen, um eine starke Überlastung vom Dach zu vermeiden.

Unsere Pergola kann starke Regenfälle standhalten, aber wir können keine absolute Wasserdichtigkeit garantieren. Bei außergewöhnlichen Wetterereignissen kann die Wasserdichtigkeit beeinträchtigt werden. Lassen Sie keine feuchtigkeitsempfindlichen Produkte unter der Pergola stehen.

Wir raten davon ab, auf das Dach oder das Gestell der Pergola zu klettern. Es besteht die Gefahr von Schäden und Verletzungen.

Tipps und Sicherheitshinweise

Je nach Standort und Fläche kann es sein, dass für den Bau eine Baugenehmigung oder ein Antrag auf Baugenehmigung erforderlich ist. Wir empfehlen Ihnen vor dem Aufbau sich an Ihre Stadtverwaltung zu wenden, um die entsprechenden Informationen zu erhalten.

Produktmontage:

- Es werden 2-3 Personen benötigt
- Entfernen Sie vor der Installation die Schutzfolie von allen Teilen
- Lassen Sie Kinder nicht in der Nähe des Montagebereichs spielen
- Achten Sie auf die Klemmgefahr
- Ziehen Sie die Schrauben nicht vollständig an, bevor Sie die entsprechenden Teile zusammen gebaut haben
- Alle Aufbauschnitte müssen genau befolgt werden
- Diagonalen und Auslotungen kontrollieren
- Befestigen Sie die Pergola erst nach dem Zusammenbau

Es dürfen keine Veränderungen am Produkt vorgenommen werden. Vom Benutzer abgeänderte Produkte, fallen nicht mehr unter die Garantie des Herstellers.

Der Standort sollte mit Bedacht gewählt sein. Es wird empfohlen, die Pergola nicht bei Regen, in der Hauptwindrichtung oder unter einem Baum aufzustellen.

Die Pergola muss auf einem ausreichend stabilen und ebenen Fundament errichtet werden. Es wird empfohlen sie auf einer Betonplatte oder auf 25 x 25 cm großen Betonklötzen an jedem Pfosten zu errichten. Wir bitten Sie, die Pergola mit Hilfe von TO-Teilen korrekt im Boden zu verankern.

Wenn Sie ihre Pergola in der Nähe des Hauses oder eines Gebäudes aufstellen möchten, achten Sie darauf, dass Regenrinnen vorhanden sind, damit Regenwasser abfließen kann. Die Pergola kann es nicht aushalten wenn Wasser von Ihrem Haus in die Pergola fließt.

Falls diese Hinweise nicht oder nur teilweise befolgt werden, erlischt die Garantie des Verkäufers.

Wartung

Eine regelmäßige Pflege des Produkts ist nötig um eine Langlebigkeit des Produkts zu gewährleisten.

Empfehlungen:

- Waschen Sie die Pergola 1–2-mal im Jahr mit Süßwasser und einem Schwamm oder Tuch. Verwenden Sie keine aggressiven Reinigungs- oder Scheuermittel.
- Überprüfen Sie regelmäßig (min 1x im Jahr) ob die Schrauben fest angezogen sind.
- Ölen Sie die Eisenwaren regelmäßig (mindestens 1x pro Jahr)
- Achten Sie darauf, dass nichts den Wasserabfluss in den Regenrinnen behindert (Blätter, Äste)
- Entfernen Sie Wasser, das sich an den Füßen der Pergola herum sammelt (heben Sie die Abdeckungen an)

Garantie

Die Garantie umfasst nicht:

- Normale Gebrauchsspuren des Produkts
- Verlust oder Bruch von Teilen beim Auspacken oder bei der Montage
- Mangel an vernünftiger Sorgfalt, Vernachlässigung, Vandalismus, Einwirkung fremder Gegenstände, Gewaltanwendung, Kontakt mit Schleifmittel, Ästhetik, Ausbau, Wiederaufbau oder Verlegung des Standorts.
- Höhere Gewalt: Hagel, starke Winde, Stürme, Schnee, Überschwemmungen, Blitzschlag...
- Veränderung des Produkts durch den Benutzer.

Die Garantie umfasst nur den Ersatz des Ersatzteils oder des gelieferten Produktes, unter Ausschluss jeglicher Kosten und Entschädigungen jeglicher Art.

Die Garantie muss bei der Verkaufsstelle (Geschäft oder Internetseite) beantragt werden, bei der Sie Ihr Produkt gekauft haben.



Teileliste pro Karton









Bevor Sie mit dem Aufbau beginnen, bitten wir Sie alle aufgeführten Bauteile auf Vollständigkeit zu prüfen. Zudem bitten wir Sie nachzuschauen, dass keine Schäden an den Teilen vorhanden sind. Fehlende oder beschädigte Teile müssen binnen 10 Werktagen beim Hersteller reklamiert werden nach Anlieferung der Ware.



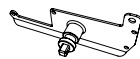
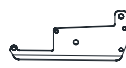
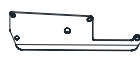
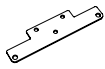
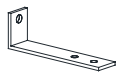



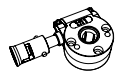

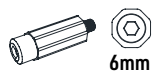





Sie können hierzu gerne unseren Kundenservice kontaktieren.

Entsorgen Sie die Verpackung nicht, ohne sicherzustellen, dass das Produkt richtig funktioniert.

KARTON 1/6 (Pfosten und lose Teile)





Referenz	Teile	Menge
A0		2
A0-1		1





Referenz	Teile	Menge
I0		3
J0		3
K0		2
L0		32
L0-1		34
EO-1		1
EO-2		1
EO-4		2
EO-5		1
M0		74
M0-1		74
N0		2
O0		2
P0		2
Q0		6

Referenz	Teile	Menge
Q0-1		6
Q0-2		6
Q0-3		6
R0		12
S0		76
T0		12
T0-1		12
U0	 lock nut	112
U0-1	 plastic nut	38
V0		188
W0		274
W0-1		24
X0		74
X0-1		12
X0-2		38







Referenz	Teile	Menge
XO-3	 6x16	2

Referenz	Teile	Menge
YO	 6x45 4mm	6

Referenz	Teile	Menge
ZO-1	 4mm	1
ZO-2	 4mm	1
ZO-3	 6mm	1
ZO-4	 6mm	1

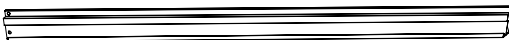
Referenz	Teile	Menge
ZO-5	 10mm	1
ZO-6	 T20	1
ZO-7		1
ZO-8		1

KARTON 2/6 (Balken)

Referenz	Teile	Menge
BO		1
BO-1		1
BO-2		1
CO-1		1
CO-2		1
EO		1
FO		2
HO		2



KARTON 3/6 (Lamellen)

Referenz	Teile	Menge
GO		10

KARTON 4/6 (Lamellen)

Referenz	Teile	Menge
GO		10

KARTON 5/6 (Lamellen)

Referenz	Teile	Menge
GO		10

KARTON 6/6 (Lamellen)

Referenz	Teile	Menge
GO		8

Schritt 1- Rahmen

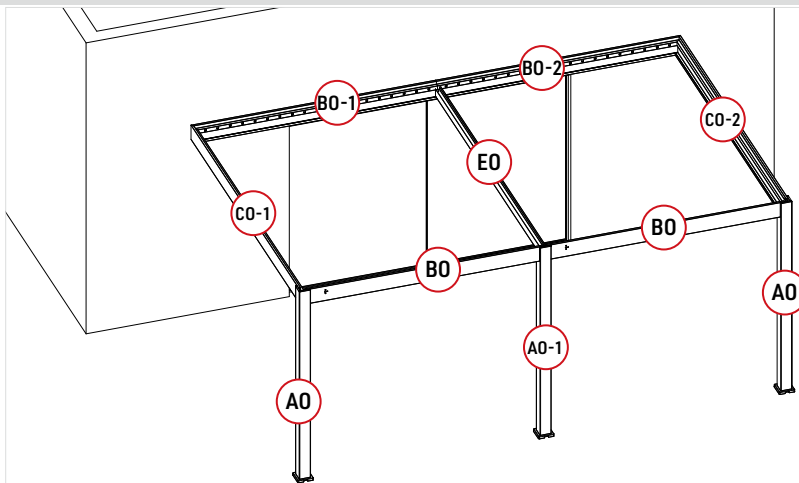

TEILE

Referenz	Teile	Menge
A0		2
A0-1		1





Referenz	Teile	Menge
B0		1
B0-1		1
B0-2		1
C0-1		1
C0-2		1
EO		1

Referenz	Teile	Menge
IO		3
JO		3
QO		6
QO-1		6
QO-2		6
QO-3		6
EO-1		1



Referenz	Teile	Menge
EO-2		1
EO-4		12
EO-5		1
TO-1		12
XO-1		12
WO-1		31

Schritt 1-1 Rahmen

Teile

A0		2
IO		2
J0		2
X0-1	 6x35  4mm	8

Werkzeuge

Z0-1	 4mm	1
Z0-2	 4mm	1

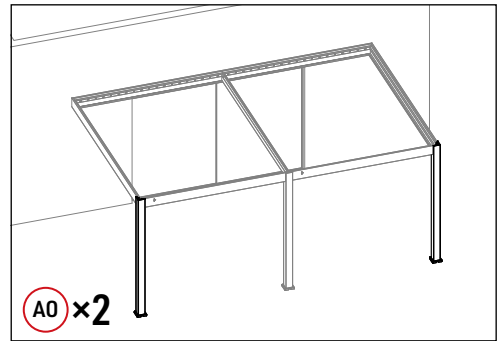

Fertigstell Diagramm

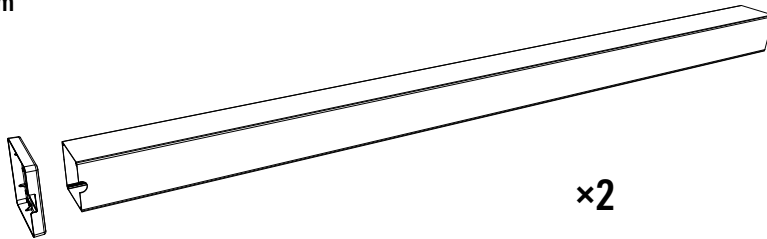

1

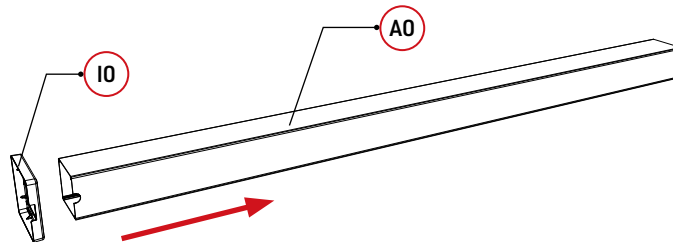

1. Platzieren Sie **IO** in **A0**, stellen Sie sicher, dass die Kerbe um die Säulen **IO** mit dem Abflussauslass ausgerichtet zum Boden der **A0**-Säule ist und platzieren Sie es in der Säule.



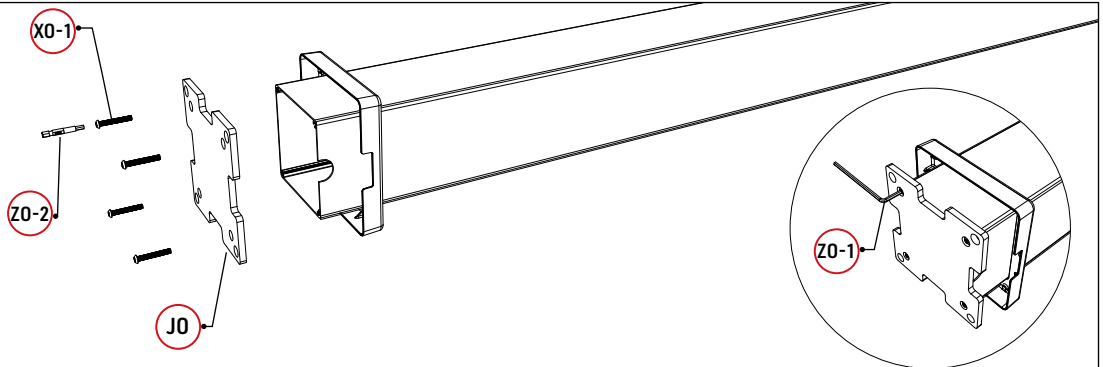

2





2. Befestigen Sie die **J0**-Grundplatte mit **X0-1** an der Unterseite der Säule und ziehen Sie sie mit dem Sechskantschlüssel **Z0-1** manuell fest.

Schritt 1-2 Rahmen

Teile

A0-1		1
IO		1
JO		1
X0-1	 6x35 4mm	4

Werkzeuge

Z0-1	 4mm	1
Z0-2	 4mm	1

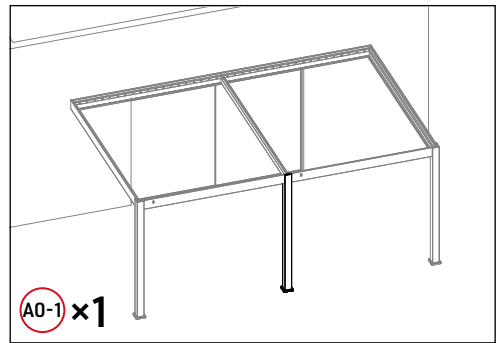

Fertigstell Diagramm

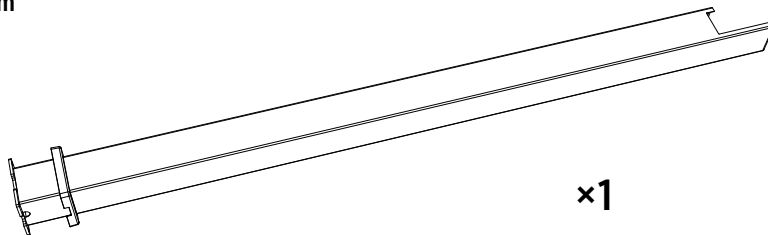

1

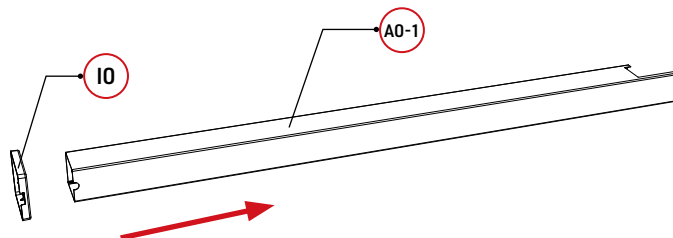

1. Platzieren Sie **IO** in **A0-1**, stellen Sie sicher, dass die Kerbe um die Säulen **IO** mit dem Abflussauslass ausgerichtet zum Boden der **A0**-Säule ist und platzieren Sie es in der Säule.

2

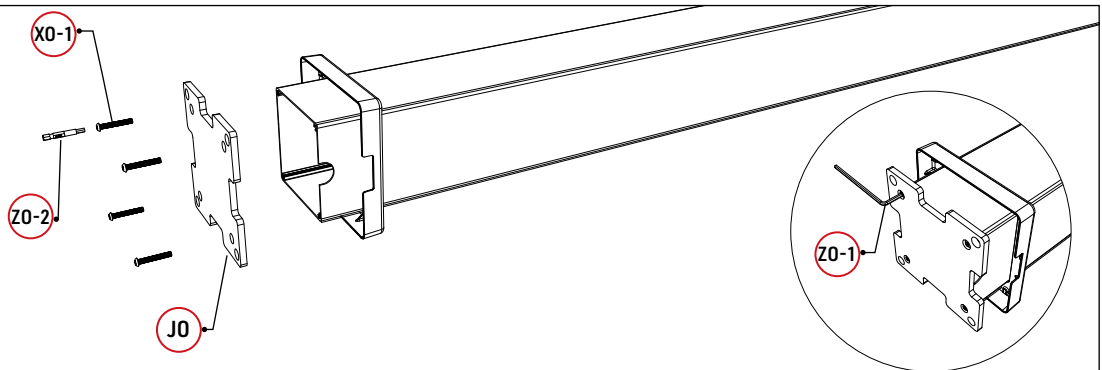



2. Befestigen Sie die **JO**-Grundplatte mit **X0-1** an der Unterseite der Säule und ziehen Sie sie mit dem Sechskantschlüssel **Z0-1** manuell fest.

Schritt 1-3 Rahmen

Teile

B0-1		1
B0-2		1

E0-4		2	WO-1		20
E0-5		1			

Werkzeuge

Z0-7		1
------	---	---

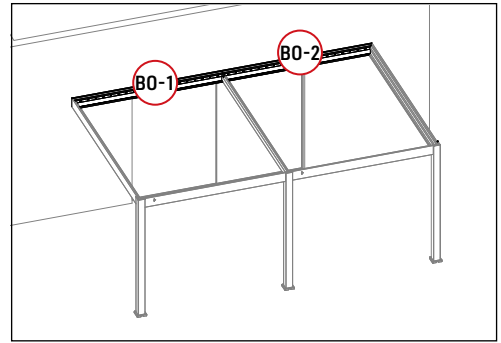

Fertigstell Diagramm

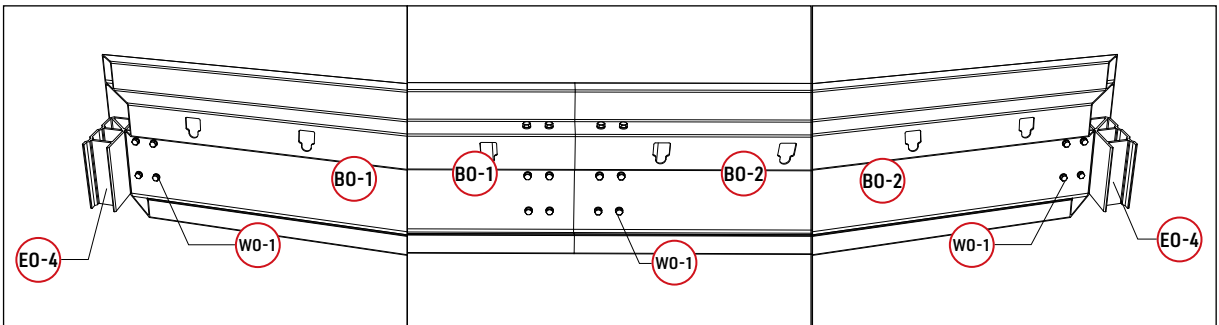
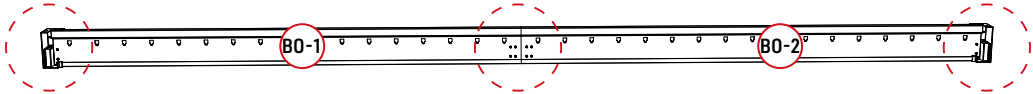

1. Setzen Sie **E0-5** in den Hohlraum von **B0-1** und sichern Sie es mit **WO-1**. Verbinden Sie **B0-2** mit **B0-1** und sichern Sie es mit **WO-1**.

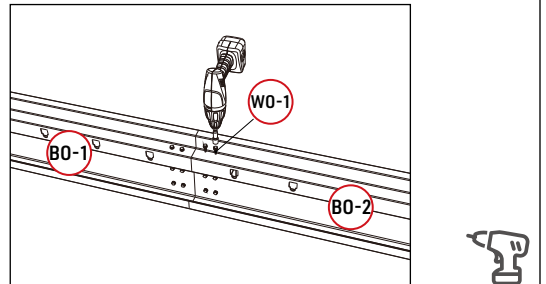
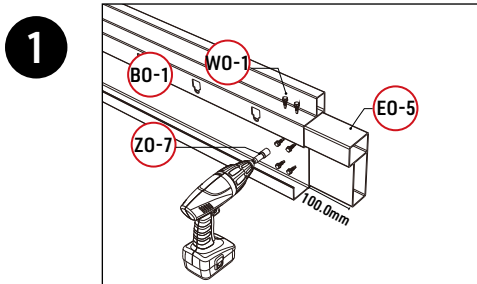

2. Fixieren Sie **E0-4** auf beiden Seiten von **B0-1** & **B0-2** und verwenden Sie dann **Z0-7**, um **E0-4** und **B0-1** mit **WO-1** zu fixieren. Fixieren Sie **E0-3** auf beiden Seiten von **B0-1** & **B0-2**.

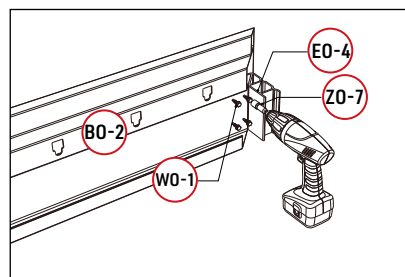
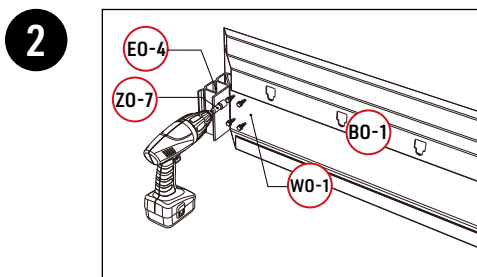

Schritt 1-4 Rahmen

Teile

T0-1		12
------	---	----

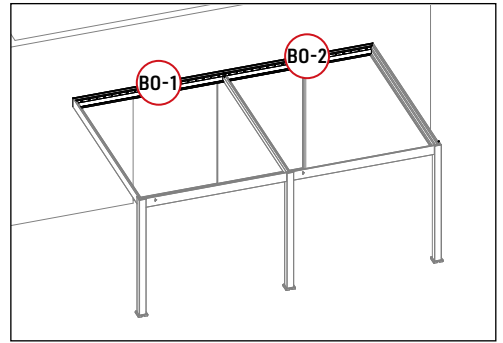

1. Platzieren Sie den Boden von **BO-1** & **BO-2** auf einer Höhe von **2370** (mm) und halten Sie ihn gerade.

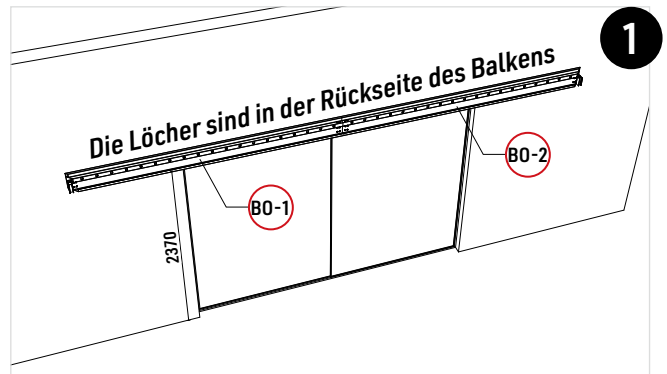
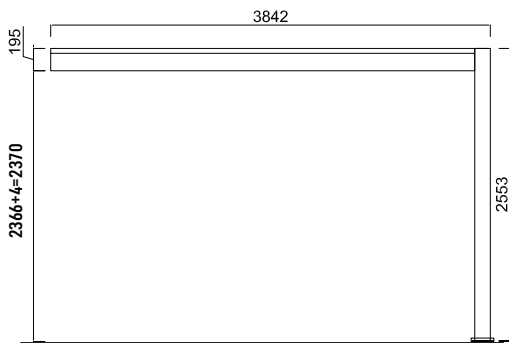

2. Suchen Sie mit einem Marker die Position des Lochs auf der Rückseite von **BO-1** & **BO-2** und markieren Sie es. Verwenden Sie zum Bohren eine Schlagbohrmaschine mit einem **M8x150 Bit**.

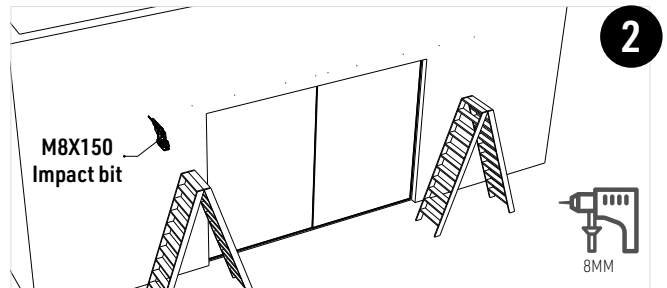
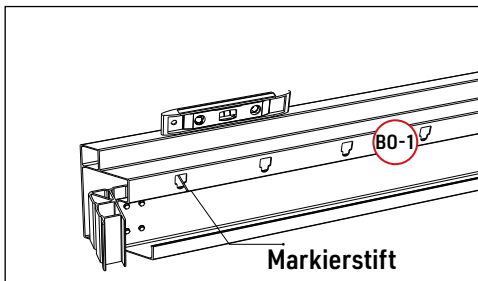



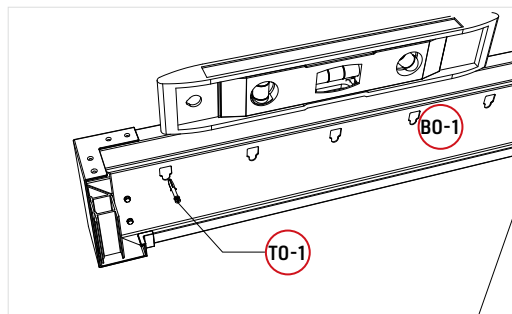



3. Führen Sie die Dehnschraube **T0-1** durch **BO-1** und befestigen Sie **BO-1** an der Wand.

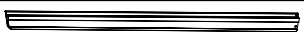





Schritt 1-5 Rahmen

Teile

CO-1		1			
CO-2		1			
QO	 6mm	4	QO-2		4
QO-1	 6mm	4	QO-3		4
			WO-1	 5x19	8

Werkzeuge

ZO-3	 6mm	1
ZO-4	 6mm	1
ZO-7		1
ZO-8		1

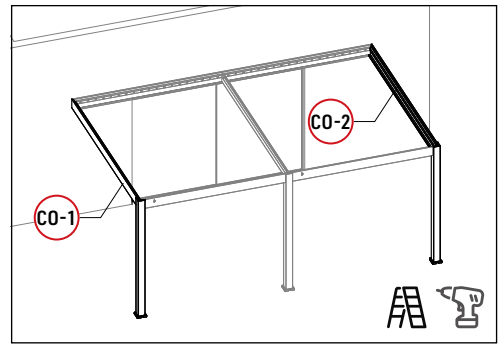

1. Verbinden Sie **CO-1** mit **AO** und fügen Sie dann das Ganze in **BO-1** ein.

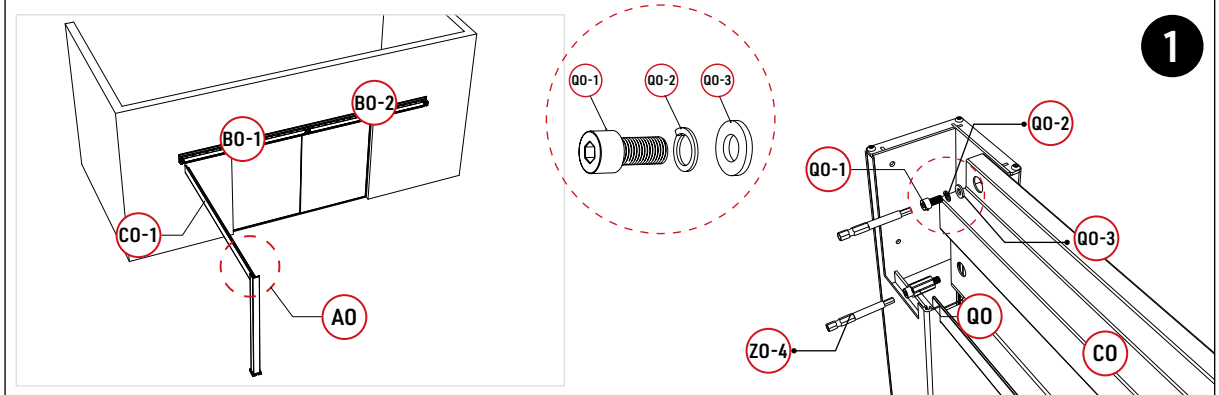

2. Verwenden Sie **WO-1**, um **CO-1** auf **BO-1** zu fixieren.

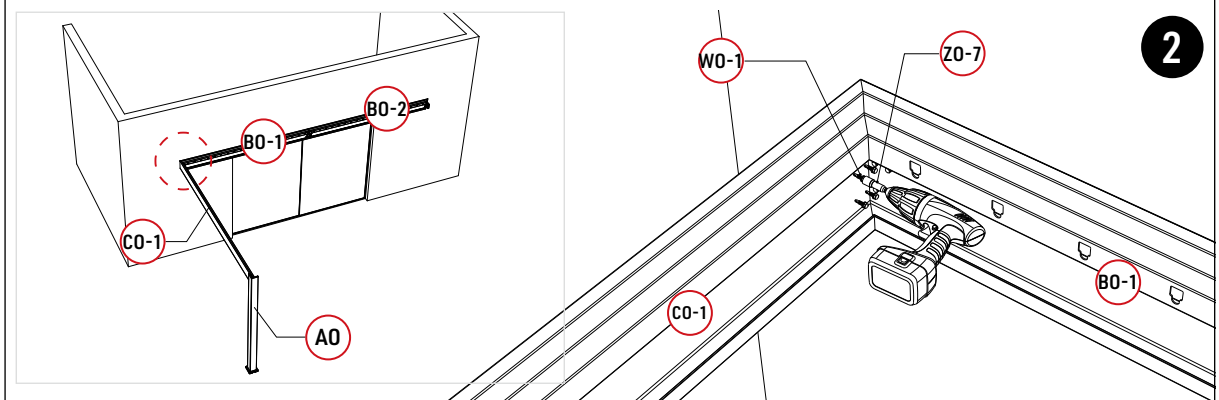

3. Wiederholen Sie den oben genannten Vorgang und befestigen Sie **CO-2** auf **BO-1** entsprechend. Verwenden Sie **ZO-3** zum manuellen Festziehen. Tragen Sie Kleber **ZO-8** Nähte auf.

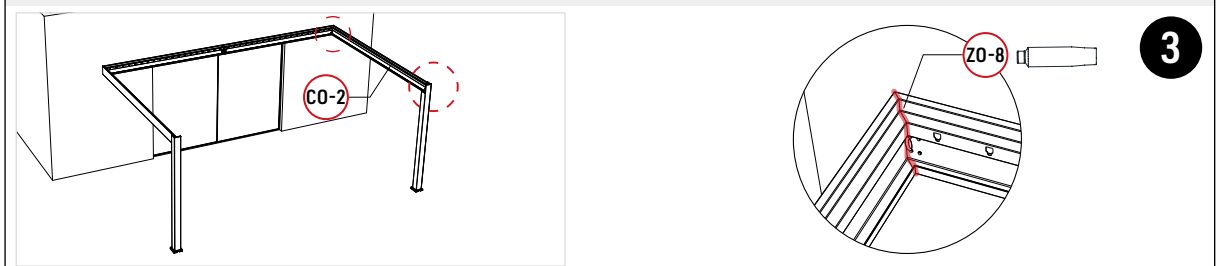

Schritt 1-6 Rahmen

Teile

A0-1		1
BO		2
Q0		4
Q0-1		4
Q0-2		4
Q0-3		4
WO-1		8

Werkzeuge

Z0-3		1
Z0-4		1
Z0-7		1
Z0-8		1

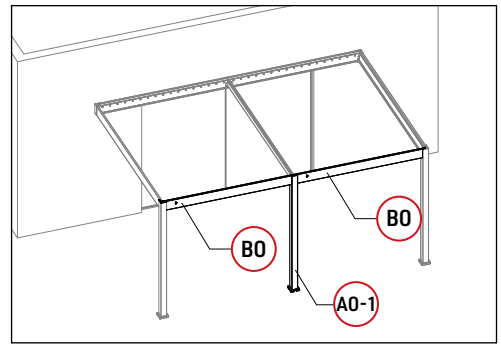

Fertigstell Diagramm

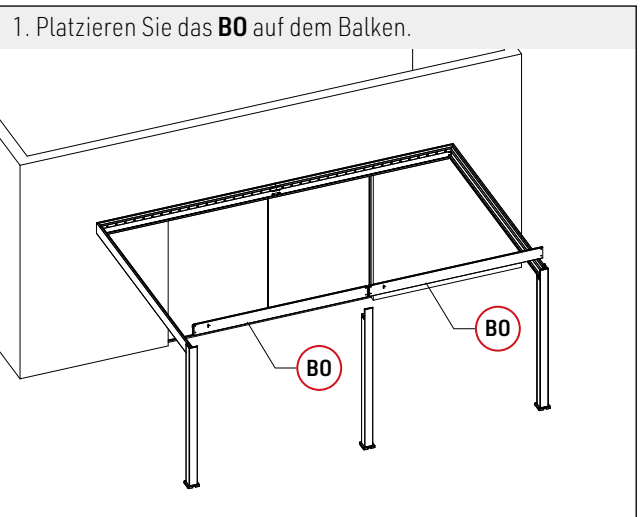
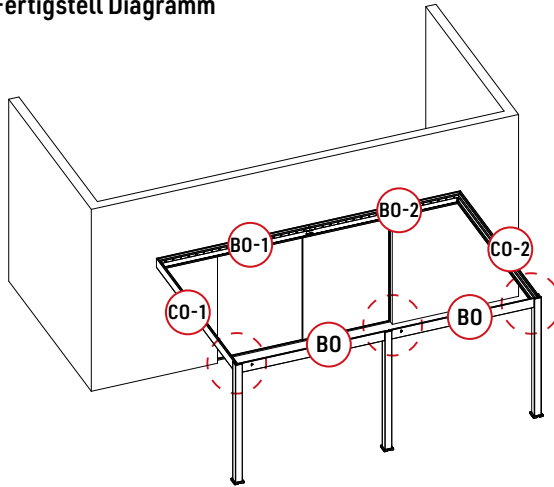



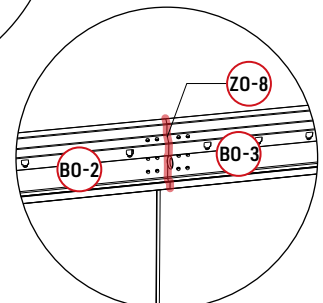
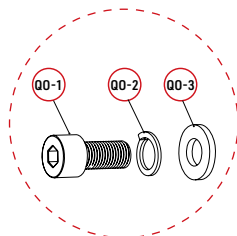
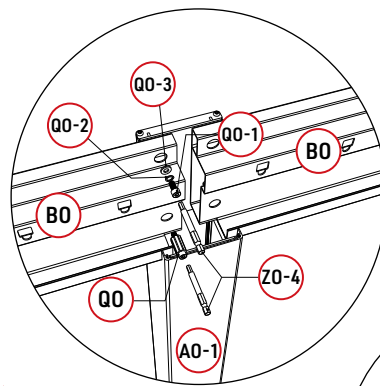
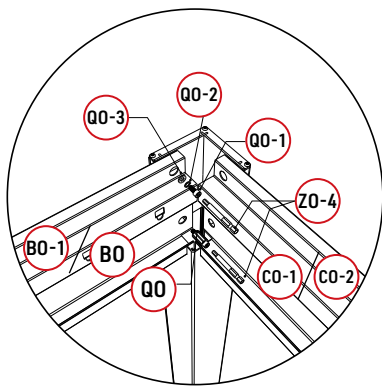



2. Verbinden Sie **BO** an beiden Enden mit **CO-1** und **CO-2**, wie in der Abbildung gezeigt. Zum Schluss mit **Z0-3** manuell festziehen. Tragen Sie Glaskleber **Z0-8** auf die Nähte auf.





Schritt 1-7 Rahmen

Teile

EO		1		
EO-1		1	XO-3	 6x16
EO-2		1		
WO	 4x12 T20	2		
WO-1	 5x19	4		

Werkzeuge

ZO-1	 4mm	1
ZO-2	 4mm	1
ZO-7	 4mm	1

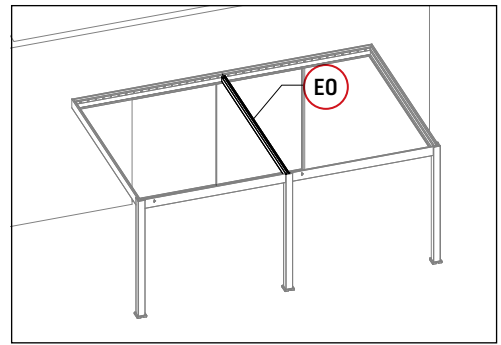

Fertigstell Diagramm

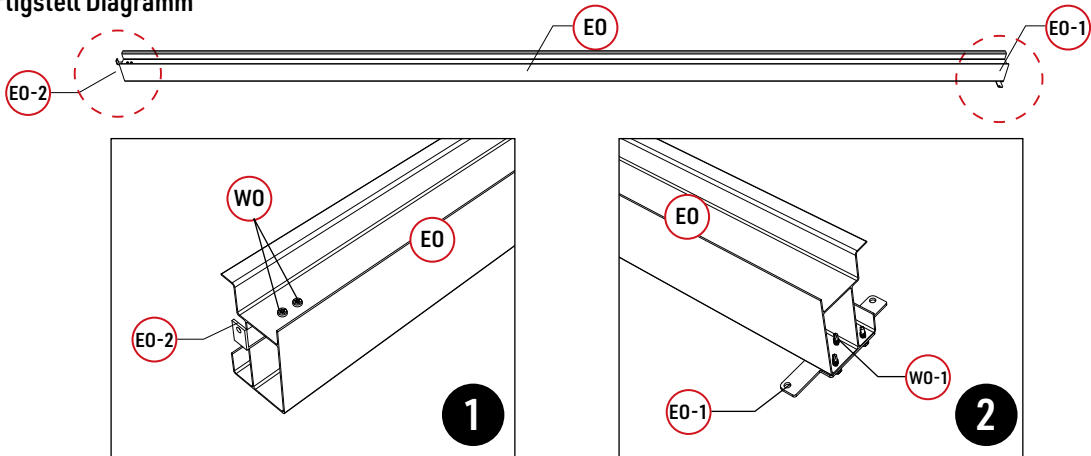

1. EO-2 auf EO fixieren.

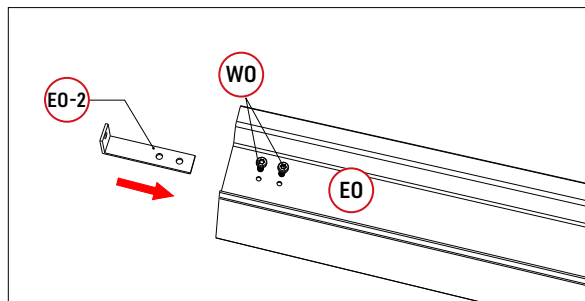

1

2. EO-1 auf EO fixieren.

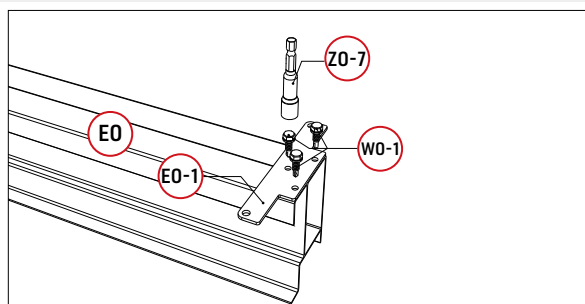

2

3. Achten Sie auf die Richtung der **EO**-Platzierung und platzieren Sie es gemäß dem Diagramm.

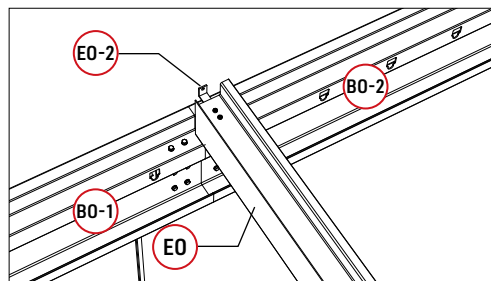
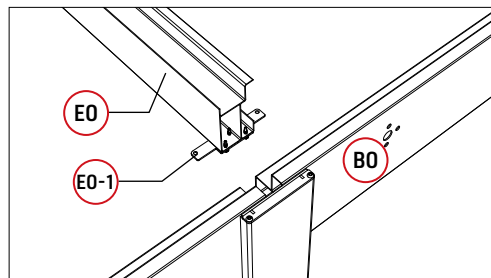
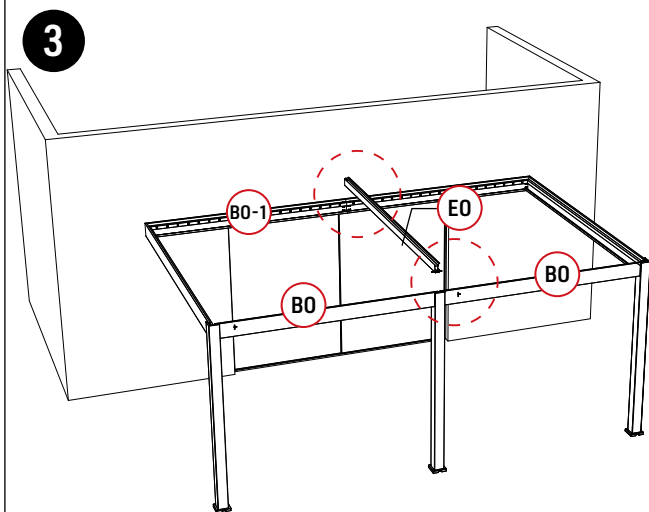

4. Verwenden Sie **XO-3**, um **EO** auf **A0-1** zu fixieren.

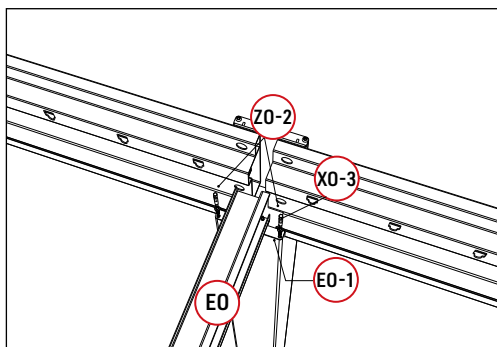
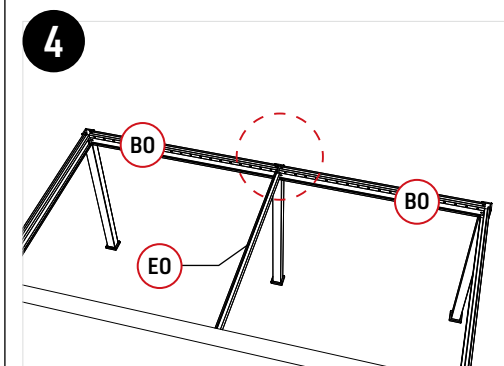

5. Verwenden Sie **WO-1**, um **EO** auf **A0-1** zu fixieren.

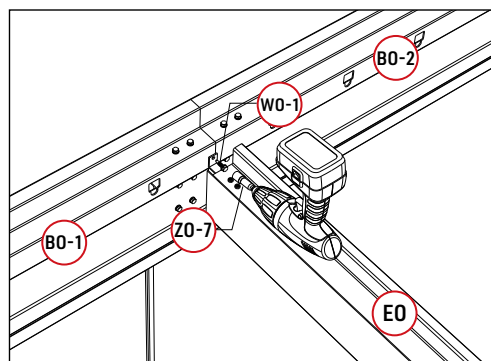
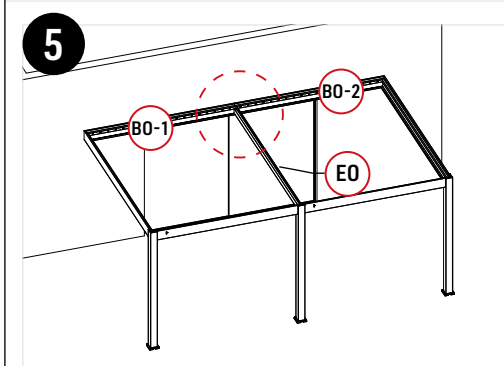



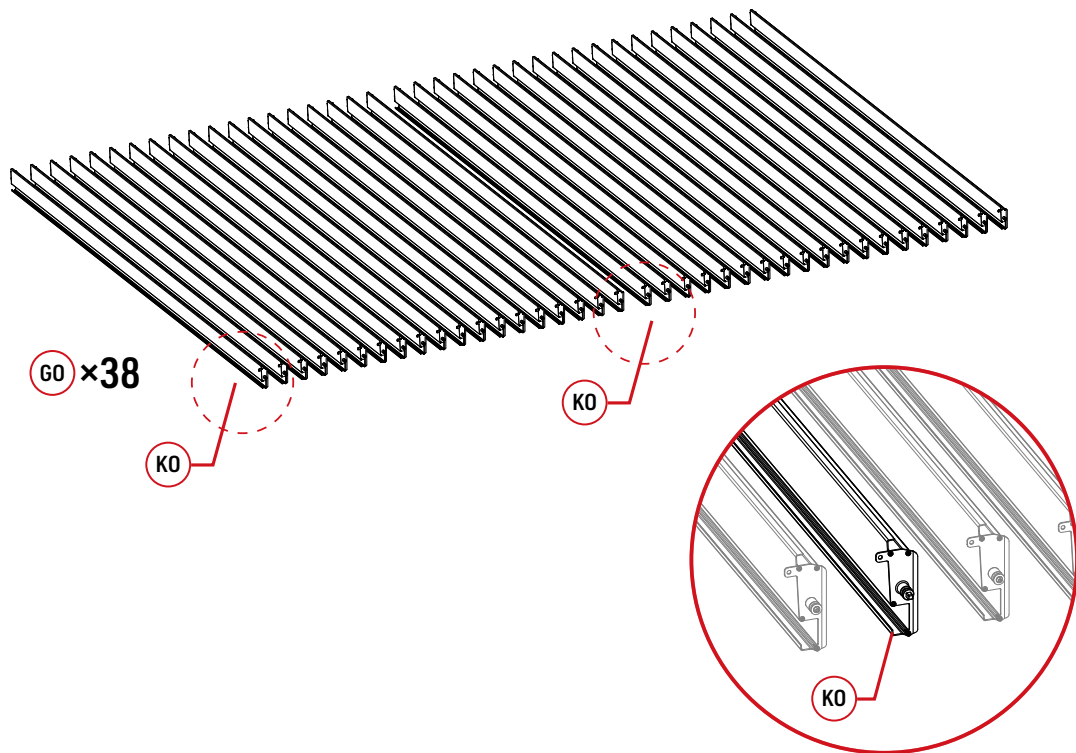





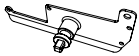

Schritt 2 (Lamellen)



TEILE

Referenz	Teile	Menge
GO		38

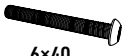
Referenz	Teile	Menge
KO		2
LO		36
LO-1		38
MO		74
MO-1		74

Referenz	Teile	Menge
VO		74
WO	 4x12  T20	304
UO	 lock nut	74
XO	 6x40  4mm	74

Schritt 2-1 (Lamellen)

Teile

LO		36	UO		lock nut	74
LO-1		38	VO			74
MO		74	XO		6x40 4mm	74
MO-1		74				

Werkzeuge

ZO-1		4mm	1
ZO-2		4mm	1

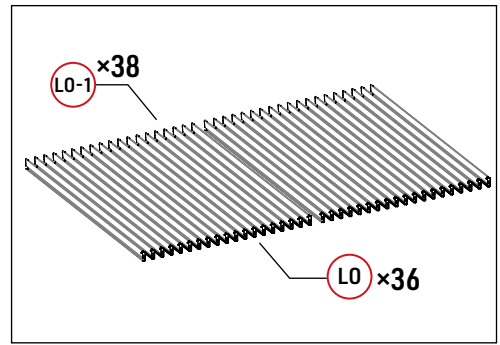

Fertigstell Diagramm

Lamellendichtungsplatte **LO-1** Anzeige

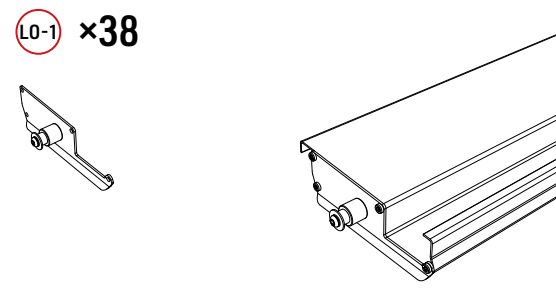

Lamellendichtungsplatte **LO** Anzeige

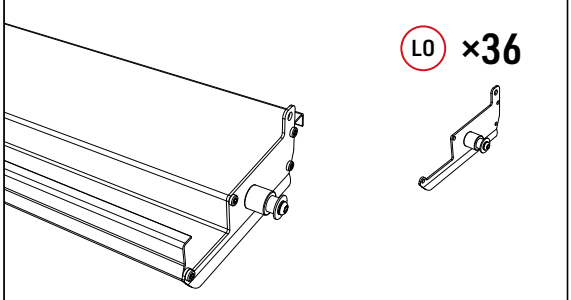

Bauen Sie die Zubehörteile gemäß den Anweisungen ein, verbinden Sie dann die gesamten Zubehörteile mit der LO-Dichtungsplatte und ziehen Sie sie mit den Kontermuttern fest.

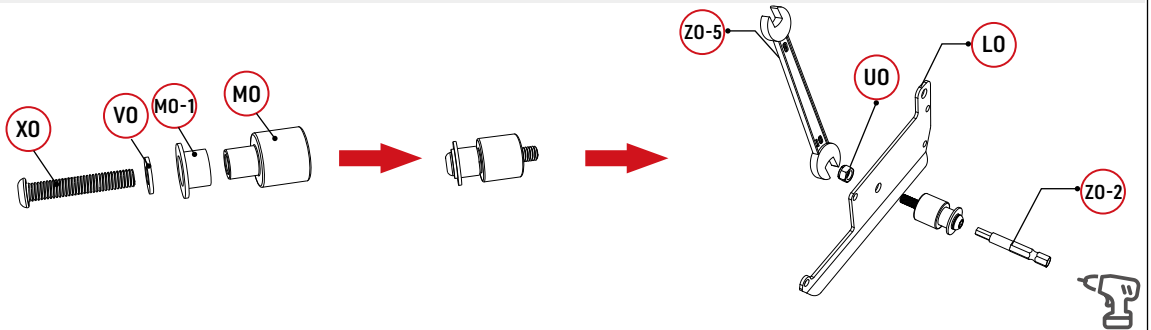

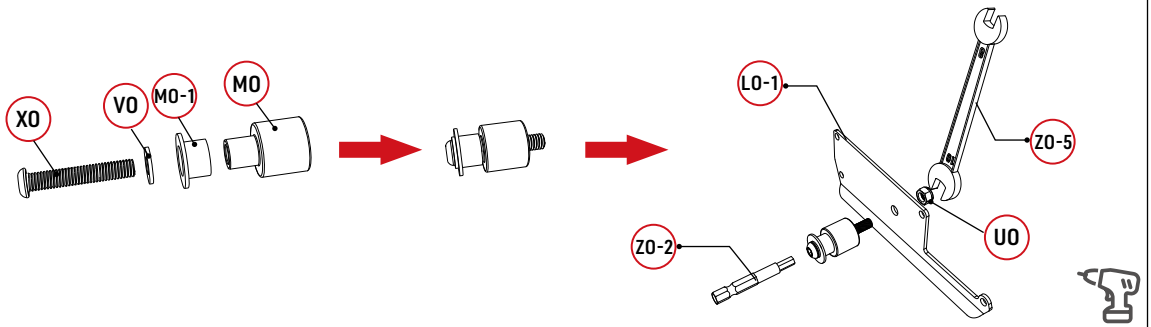

Bauen Sie die Zubehörteile gemäß den Anweisungen ein, verbinden Sie dann die gesamten Zubehörteile mit der LO-1-Dichtungsplatte und ziehen Sie sie mit den Kontermuttern fest.



Schritt 2-2 (Lamellen)

Teile

KO		2
LO-1		2
WO		16

Werkzeuge

ZO-6		1
------	---	---

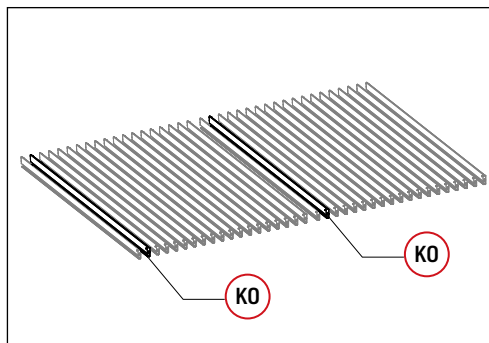

Fertigstell Diagramm

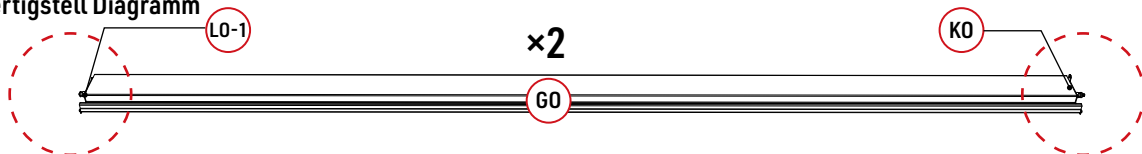

Verwenden Sie **ZO-6** mit **WO**, um **KO** an den Lamellen zu verriegeln.

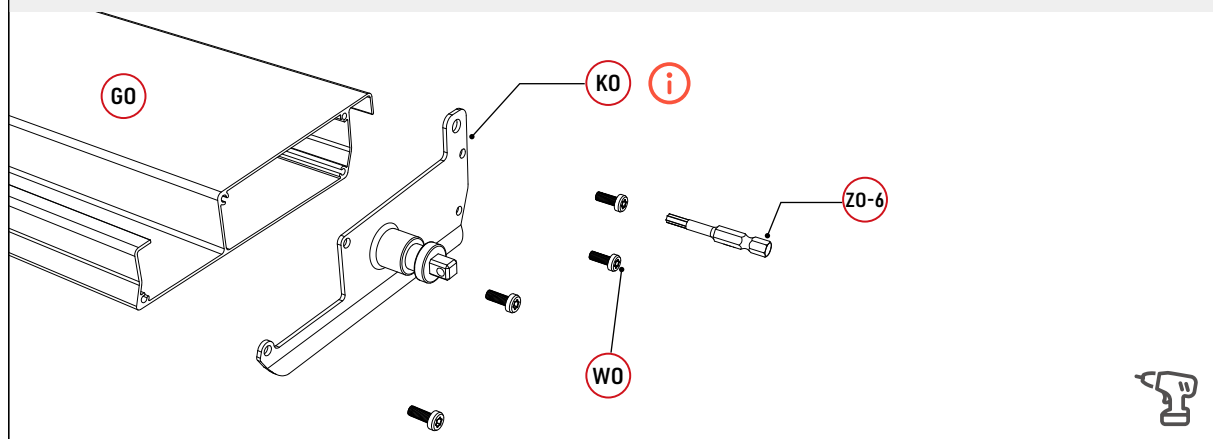



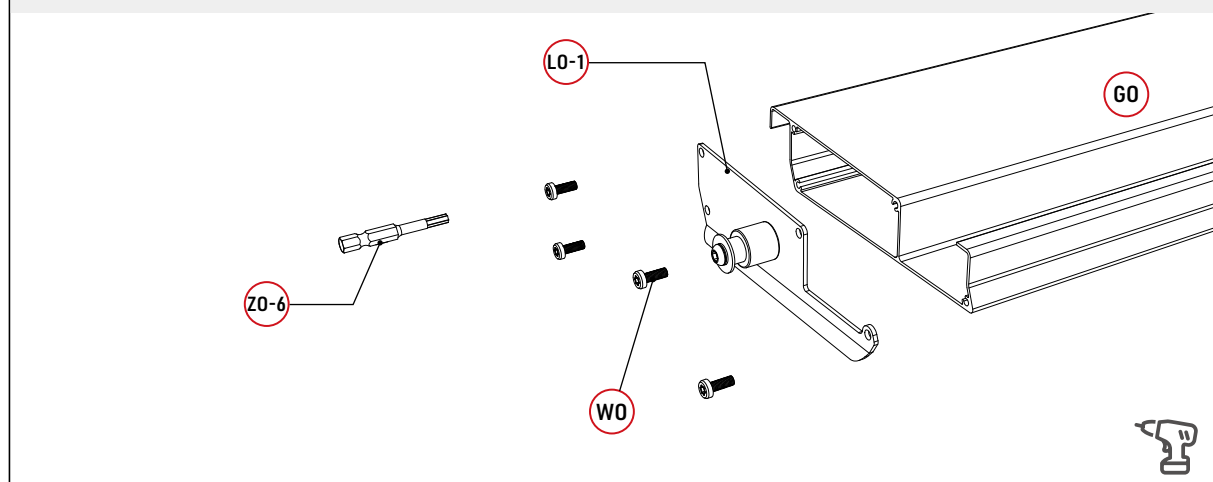

Verwenden Sie **ZO-6** mit **WO**, um **LO-1** an den Lamellen zu verriegeln.



Schritt 2-3 (Lamellen)

Teile

LO		36
LO-1		36
WO	 	288

Werkzeuge

ZO-6		1
------	---	---

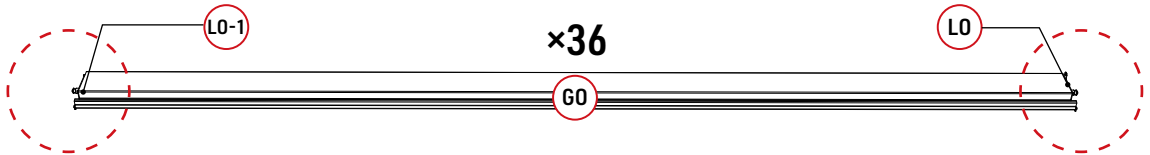
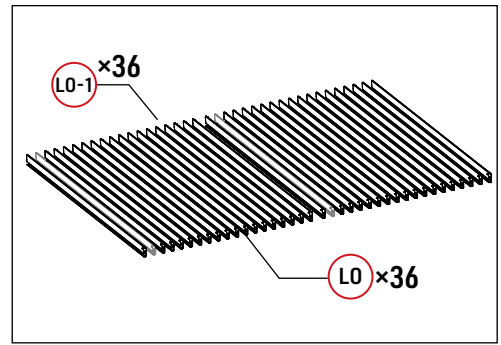

Verwenden Sie **ZO-6** mit **WO**, um **KO** an den Lamellen zu verriegeln.

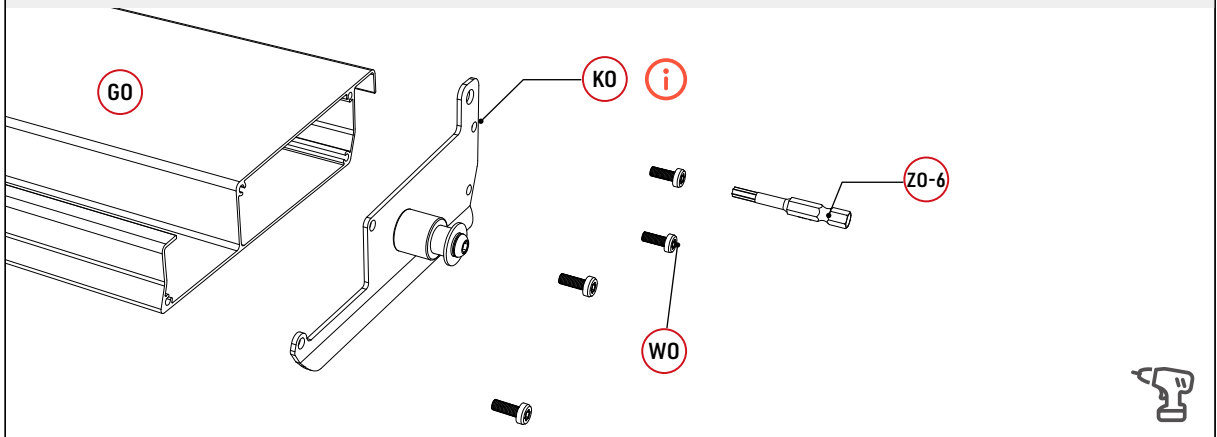

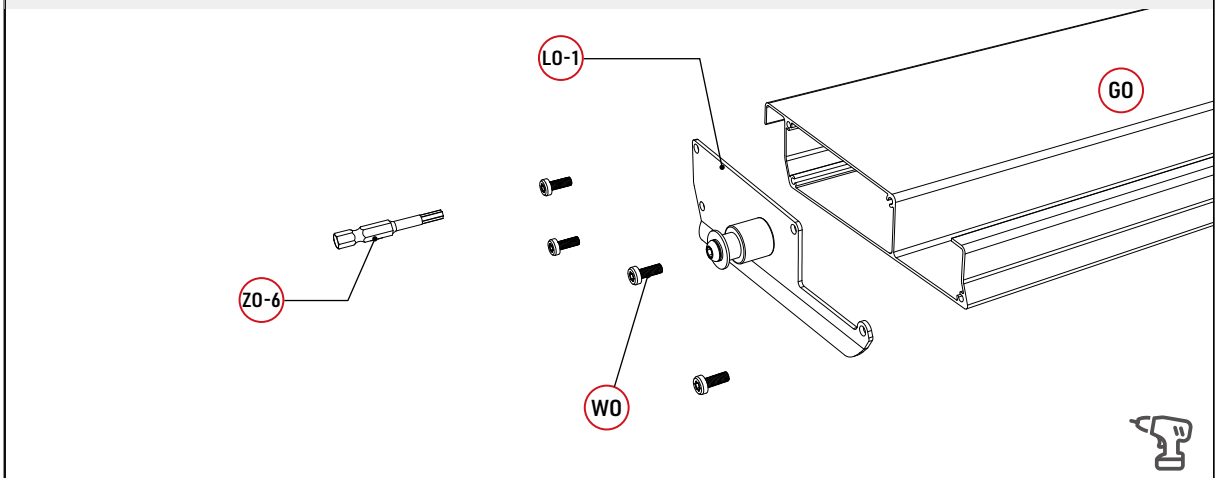

Verwenden Sie **ZO-6** mit **WO**, um **LO-1** an den Lamellen zu verriegeln.

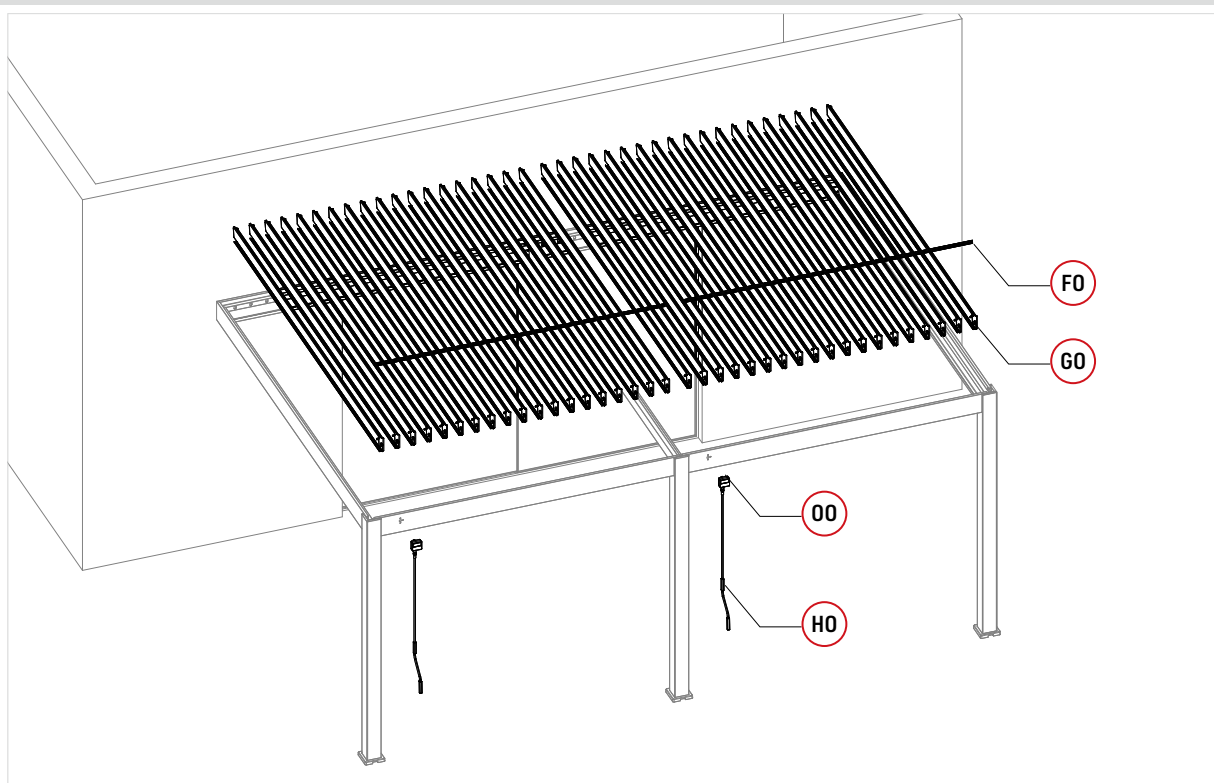

Schritt 3 (Verbinden)

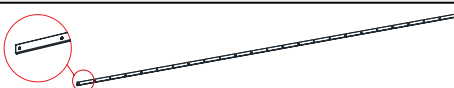

TEILE

Referenz	Teile	Menge
FO		2
HO		2

Referenz	Teile	Menge
NO		2
OO		2
PO		2
RO		12
SO		76

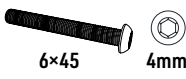
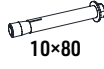
Referenz	Teile	Menge
VO		114
YO		6
TO		12

Schritt 3-1 (Verbinden)

Teile

SO



76

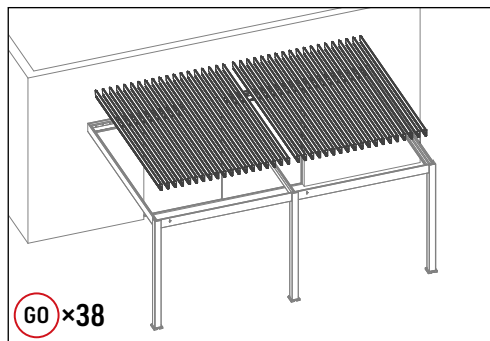

Fertigstell Diagramm

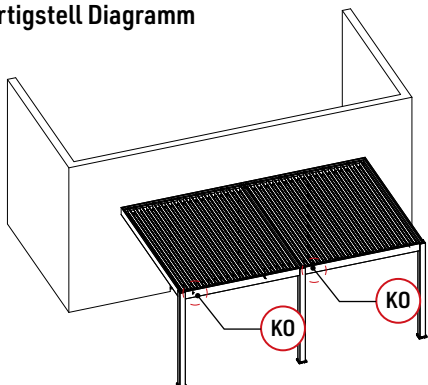

Setzen Sie zuerst die Lamellen mit integrierter Kappe (Hauptlamelle) auf den Balken.

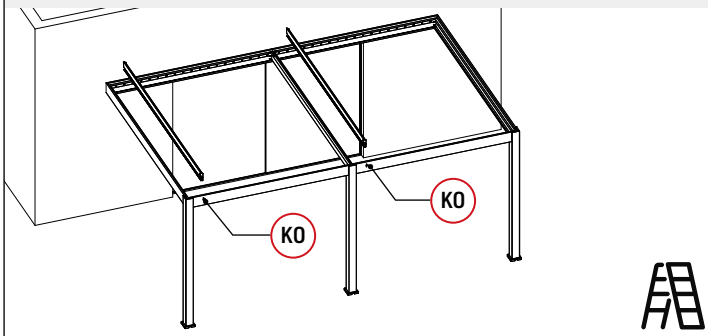

Schieben Sie zunächst die Lamelle in der Nähe des **BO**-Abschnitts in das Loch.

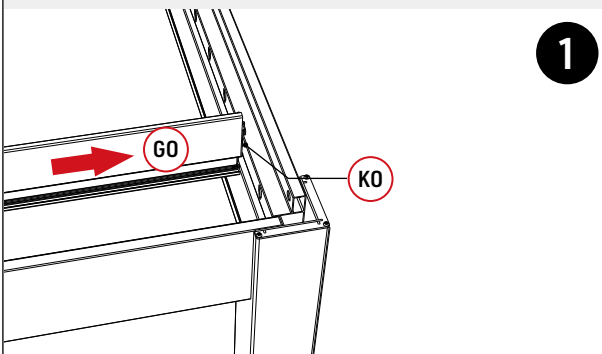

Stecken Sie dann einen weiteren Abschnitt in das Loch an der Seite von **BO-1**.

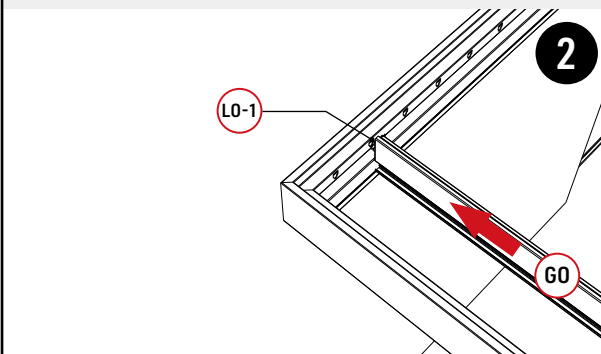

Bedecken Sie beide Enden der Lamellen mit **SO**.

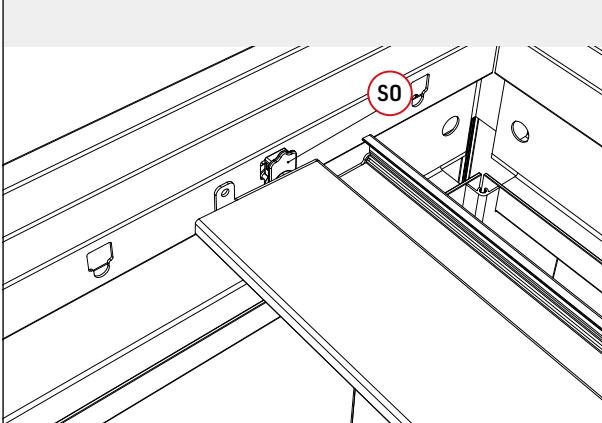

Installieren Sie nacheinander weitere Lamellen.

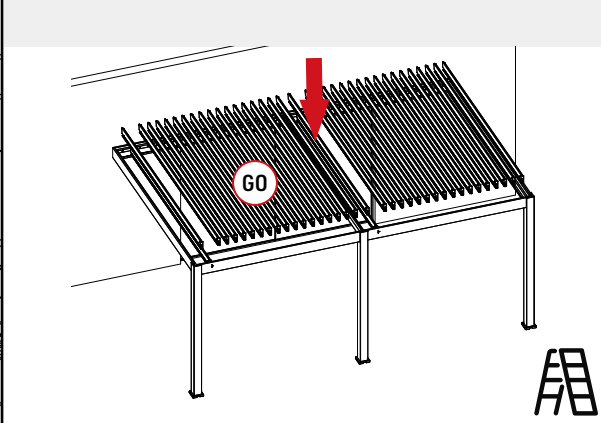

Schritt 3-2 (Verbinden)

Teile

HO		2
NO		2
OO		2
PO		2

Werkzeuge

ZO-1		1
ZO-2		1

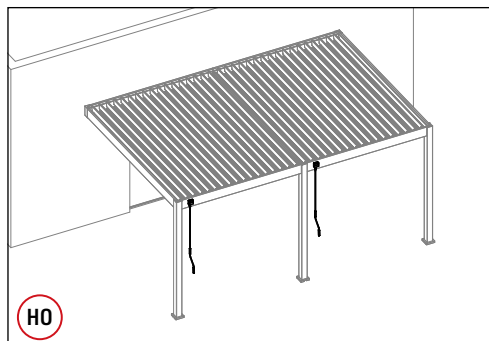

Fertigstell Diagramm

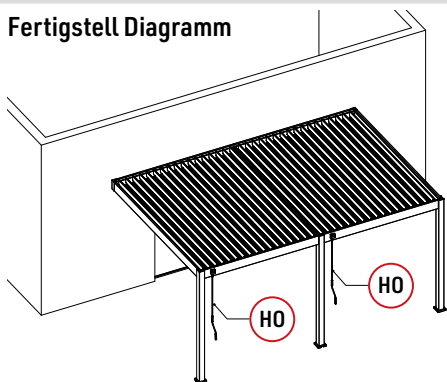

1. Setzen Sie die **PO**-Spindel in das Loch ein.

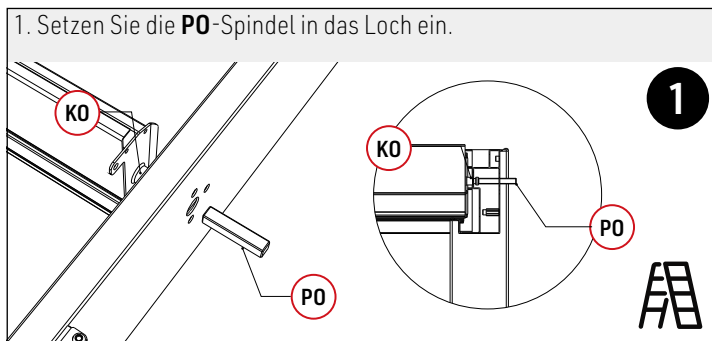

2. Platzieren Sie zuerst **OO**, dann montieren Sie **NO** und befestigen Sie es anschließend mit **YO**.

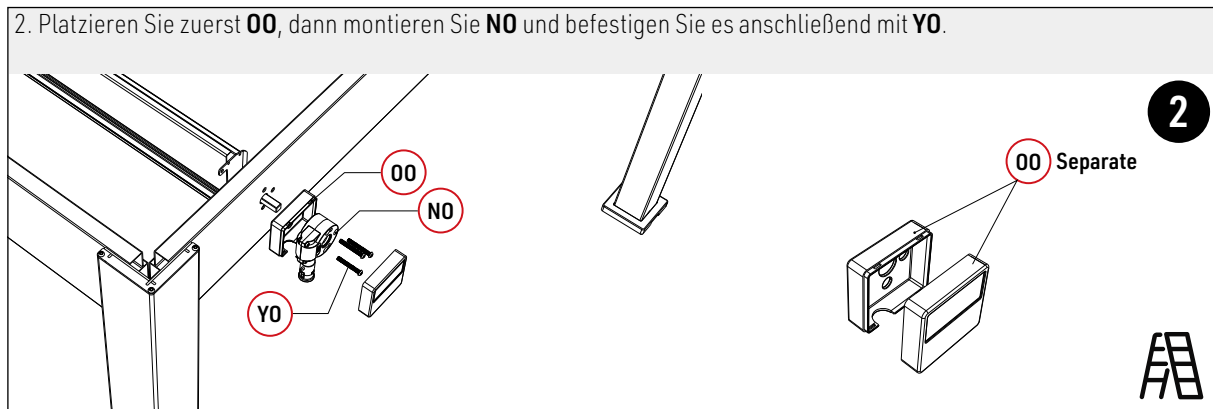



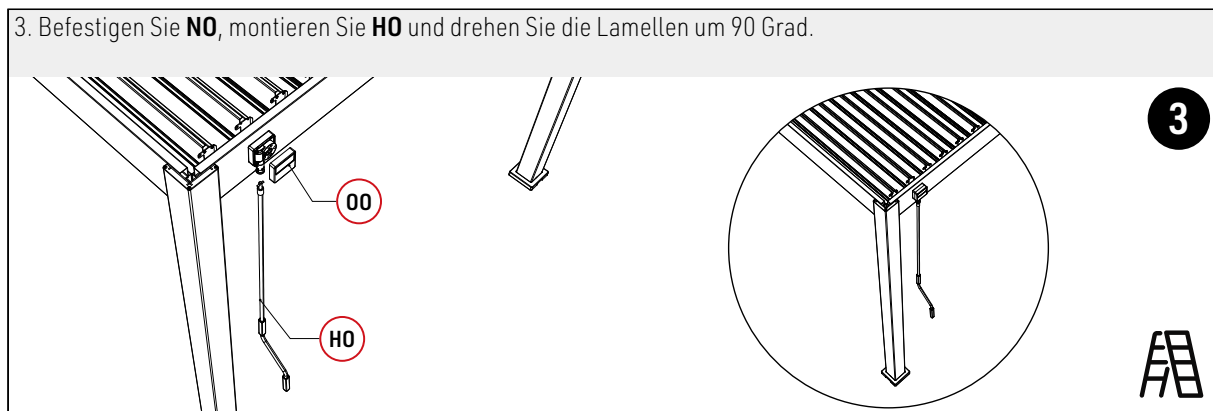

3. Befestigen Sie **NO**, montieren Sie **HO** und drehen Sie die Lamellen um 90 Grad.





Schritt 3-3 (Verbinden)

Teile

FO		2
UO	 lock nut	38
UO-1	 plastic nut	38
VO		114

Werkzeuge

Z0-1	 4mm	1
Z0-2	 4mm	1

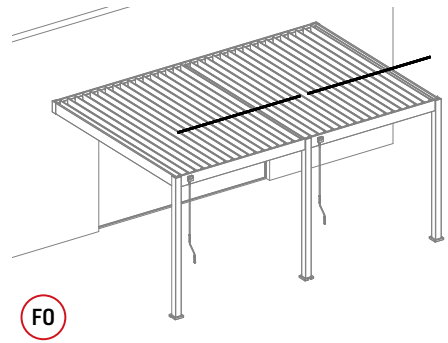

1. Verwenden Sie zunächst **X0-2**, um die beiden **VO**-Stücke durchzuziehen, und verwenden Sie **UO-1**, um sie an der Lamellenkappe zu befestigen.

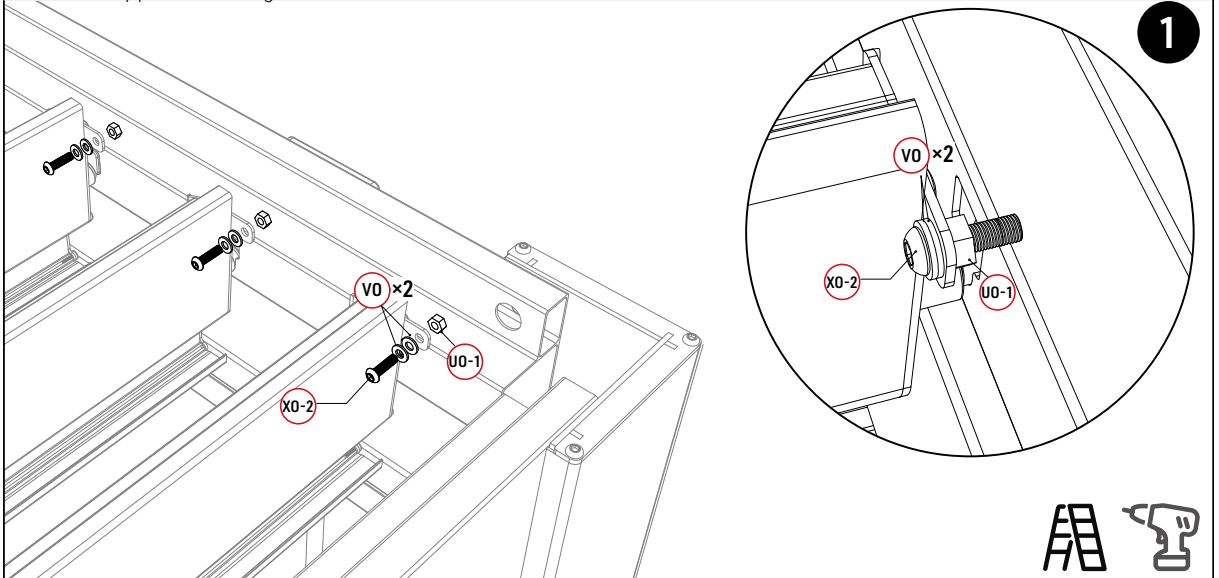

2. Verbinden Sie **FO**, verwenden Sie **VO** und **UO** zum Fixieren.

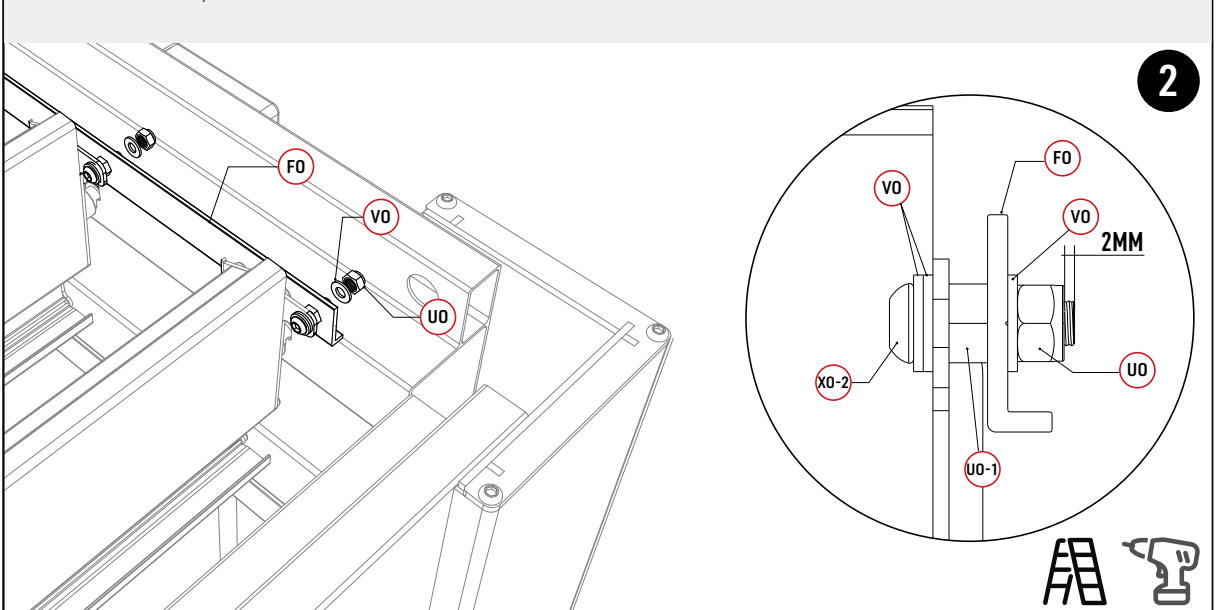

Schritt 3-4 (Verbinden)

Teile

RO		12	TO		12
----	---	----	----	---	----

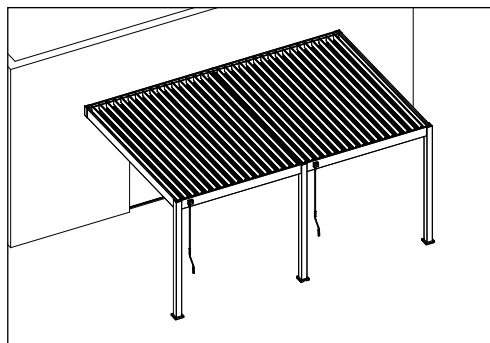

Verwenden Sie **RO**, um das Loch im Balken abzudecken

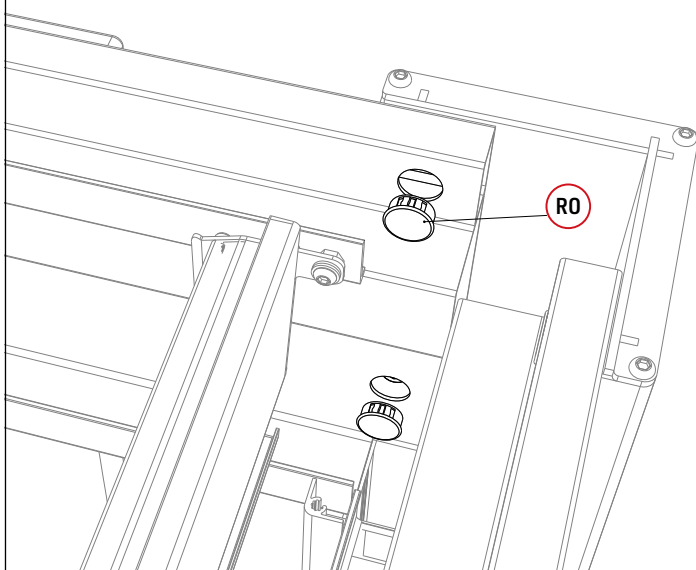

Prüfen Sie die Größe. Verwenden Sie einen **Ø12-mm-Bohrer** um Löcher an der Stelle, an der die Stahlplatte befestigt werden soll zu bohren. Befestigen Sie die Stahlplatte dann mit **TO**. Verwenden einen M17-Schlüssel zum Befestigen von **TO**.

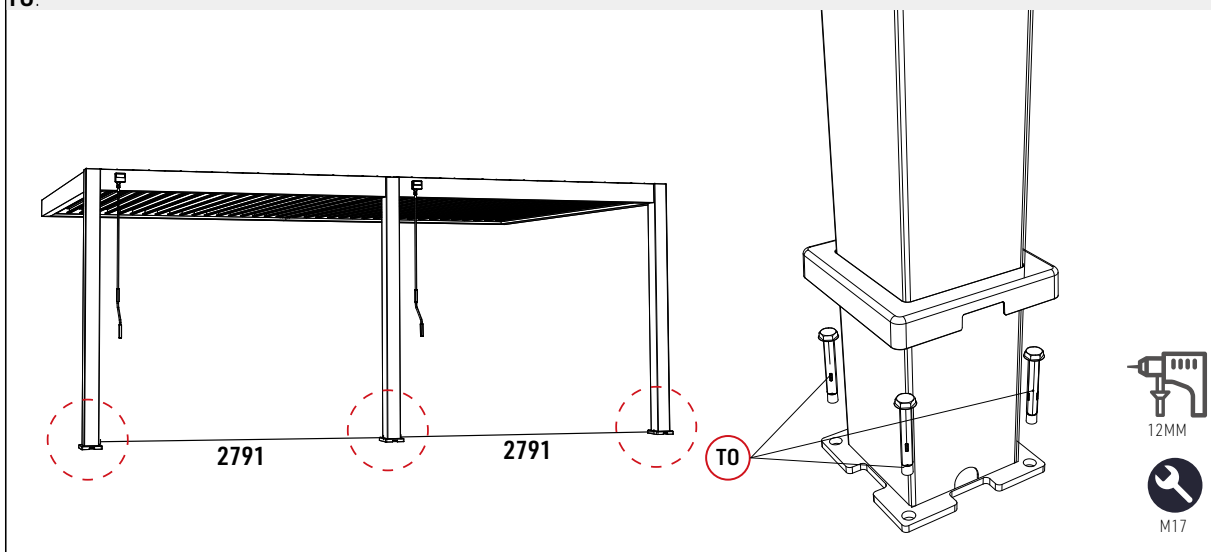

4x6 meter Wall Pergola Aluminium

Assembly Instructions - EN

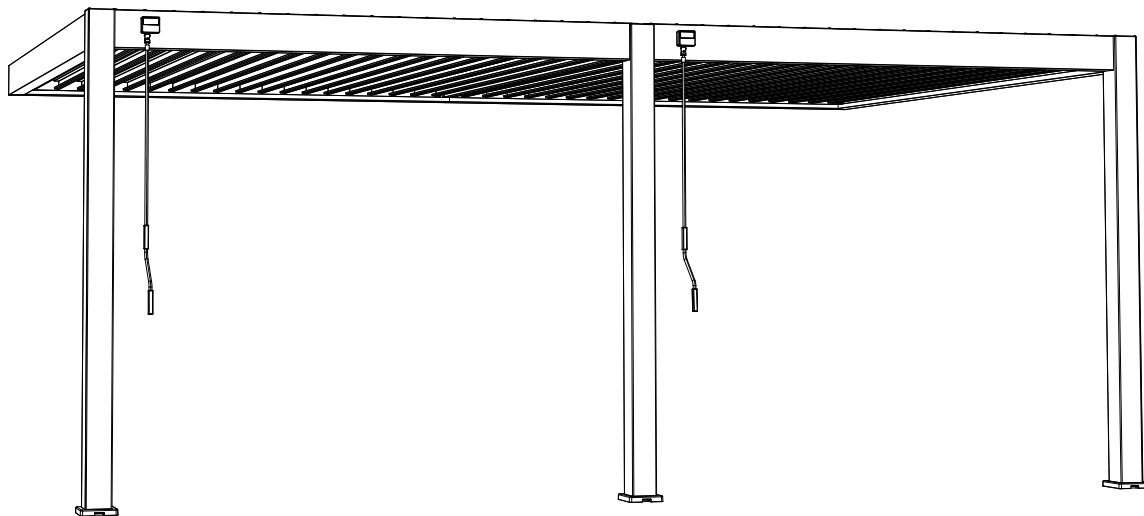

Deluxe Aluminium Wall Pergola 4x6meter

These instructions have to be saved during the whole product life cycle. We advise you to read these very carefully before proceeding to the assembly. The user will be reliable for any damages or injuries caused due to incorrect or improper installation.

NECESSARY TOOLS AND SAFETY GEAR (NOT SUPPLIED)

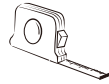
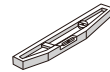

2D FOOTING MEASUREMENT (dimensions in mm)

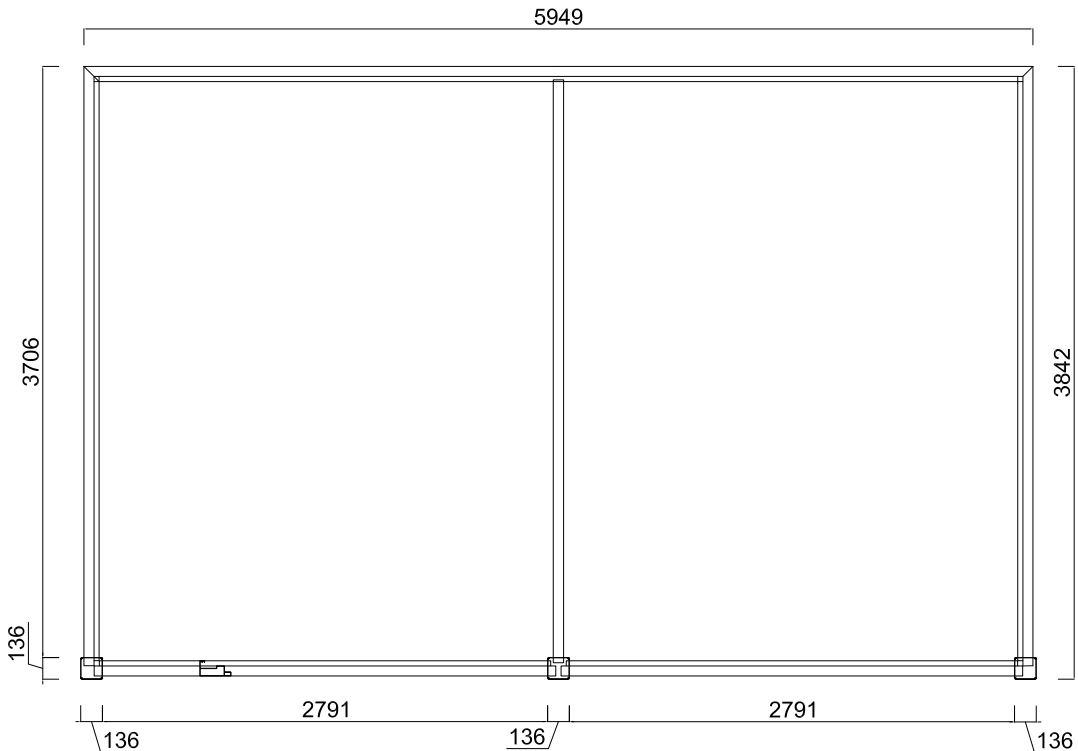

3D FOOTING MEASUREMENT (dimensions in mm)

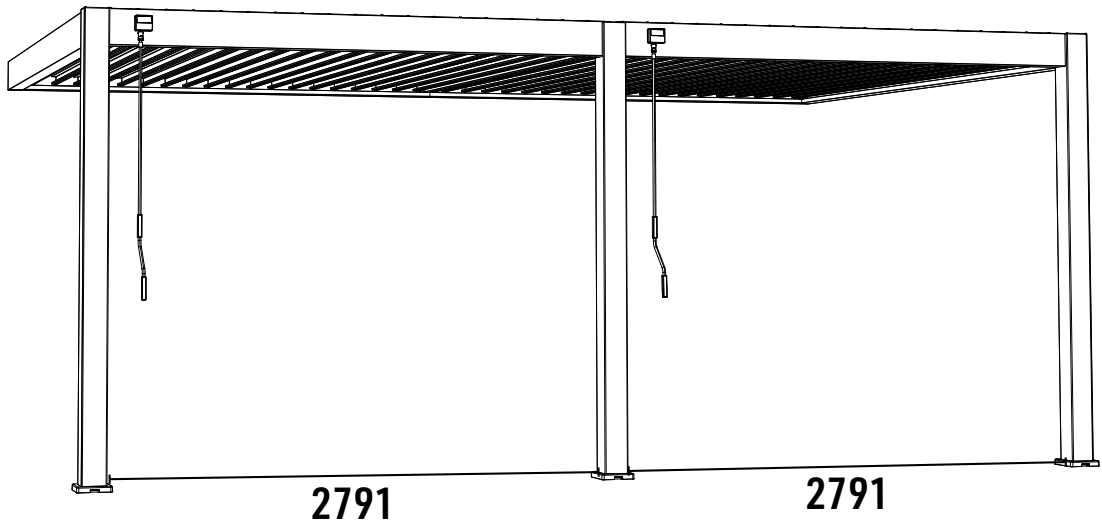

PRECAUTION OF USE

This product should not be used in extreme weather: storms, violent winds, hail, and snow. We guarantee the resistance of the pergola for winds up to 100 km/h and a maximum snow weight of 50kg/m².

As in the case of strong winds or snow, we highly recommend leaving the louvers open. To maintain good working conditions of your louvers, please clear any snow from them.

Our pergola can withstand heavy rain, but we cannot guarantee it will be 100% waterproof due to some extreme weather conditions.

Exceptional climatic events may compromise the perfect sealing of the product.

To avoid any damages and injuries, we do not recommend climbing on the roof or the structure of the pergola.

TIPS AND SAFETY INSTRUCTIONS

Depending on the location and surface area, construction may be subject to building permits. Make sure you have checked with your local authorities to obtain the needed information before the assembly.

Product assembly :

- At least 2/3 people required
- Remove protective film (around 1 hour needed)
- Do not keep children near the assembly area
- Beware of the risk of pinching
- Do not tighten the screws before assembling the whole product
- All assembly steps must be carefully followed
- Check the level of the structure on all sides
- Do not anchor the pergola before assembling the whole product

No changes can be made to the product. Products tampered with by the user are not covered by the warranty, thus being declared as void.

The location should be chosen carefully. It is recommended to avoid mounting your pergola on a rainy day, facing the prevailing winds, and under an overhanging tree.

The pergola must be mounted on a flat-level foundation. It is recommended to install it on a concrete slab or 25x25 cm concrete pads at each post. Please, anchor the pergola properly to the ground using expansion screw.

If you would like to mount your pergola near your house or a building, please check the presence of gutters for water drainage.

Should these instructions not be followed or only partially, the warranty will be voided by the seller.

MAINTENANCE

Regular maintenance is necessary to ensure its longevity and aesthetic appearance.

We recommend to :

- Clean your pergola once or twice a year with fresh water using a sponge or cloth.
- Do not use detergent or an abrasive material.
- Check the tightness of the screws regularly (at least once a year).
- Oil fastening regularly (at least once a year).
- Make sure that nothing hinders the water flow in the gutters (leaves, branches...).
- Remove any water that might stagnate around the legs of the pergola (lift the posts skirts).

MAINTENANCE

This warranty does not cover :

- Normal wear and tear inherent from the products.
- Loss or breakage of any part during unpacking or installation.
- Lack of care, neglect, vandalism, impact with foreign body, force, contact with a brasives material, product aesthetics, disassembly, rebuilding or relocation.
- Force majeure: hail, high winds, storms, snow, floods, lightning etc...
- Product tampered with by the user.

The warranty only takes in account the replacement of spare parts or the provided product, no refund will be issued.

All warranty claims must be made at the sales outlet (store or website) where the product has been purchased.

PARTS LISTS (PER CARTON)



Before proceeding with the assembly of your louvered pergola, it is necessary to check that all parts listed are supplied and not damaged.











Any missing part must be reported within 10 days of delivery.

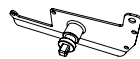

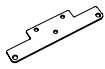
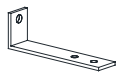



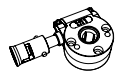

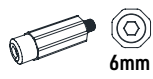





You can either go through your local outlet store or make the request directly on our website.

Do not discard the packaging without ensuring that the product is functioning properly.

CARTON 1/6(POSTS AND LOOSE PARTS)





Reference	Parts	Quantity
A0		2
A0-1		1





Reference	Parts	Quantity
I0		3
J0		3
K0		2
L0		32
L0-1		34
EO-1		1
EO-2		1
EO-4		2
EO-5		1
M0		74
M0-1		74
N0		2
O0		2
P0		2
Q0		6

Reference	Parts	Quantity
Q0-1		6
Q0-2		6
Q0-3		6
R0		12
S0		76
T0		12
T0-1		12
U0		112
U0-1		38
V0		188
W0		274
W0-1		24
X0		74
X0-1		12
X0-2		38







Reference	Parts	Quantity
XO-3	 6x16	2

Reference	Parts	Quantity
YO	 6x45 4mm	6

Reference	Parts	Quantity
ZO-1	 4mm	1
ZO-2	 4mm	1
ZO-3	 6mm	1
ZO-4	 6mm	1

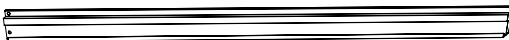
Reference	Parts	Quantity
ZO-5	 10mm	1
ZO-6	 T20	1
ZO-7		1
ZO-8		1

CARTON 2/6(BEAMS)

Reference	Parts	Quantity
B0		1
B0-1		1
B0-2		1
CO-1		1
CO-2		1
EO		1
FO		2
HO		2



Connecting Bar(FO) & Brush Inside!



ATTENTION!

CARTON 3/6(LOUVERS)

Reference	Parts	Quantity
GO		10

CARTON 4/6(LOUVERS)

Reference	Parts	Quantity
GO		10

CARTON 5/6(LOUVERS)

Reference	Parts	Quantity
GO		10

CARTON 6/6(LOUVERS)

Reference	Parts	Quantity
GO		8

Steps 1-FRAME

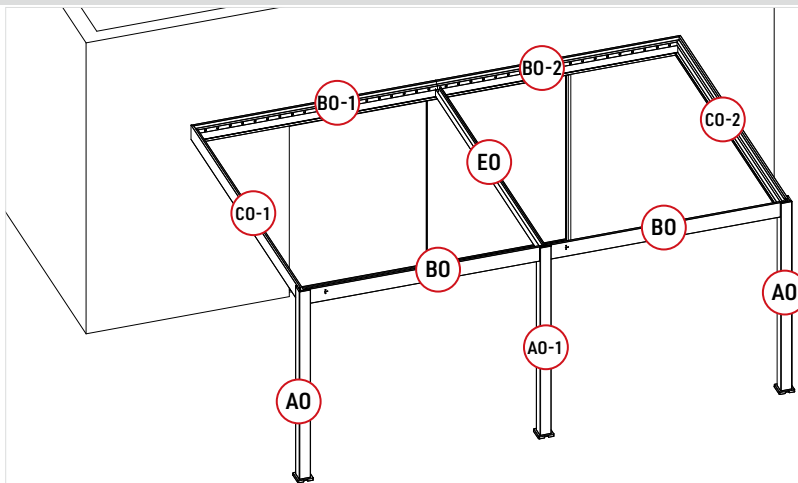

PARTS

Reference	Parts	Quantity
A0		2
A0-1		1





Reference	Parts	Quantity
B0		1
B0-1		1
B0-2		1
C0-1		1
C0-2		1
EO		1

Reference	Parts	Quantity
IO		3
JO		3
QO		6
QO-1		6
QO-2		6
QO-3		6
EO-1		1



Reference	Parts	Quantity
EO-2		1
EO-4		12
EO-5		1
TO-1		12
XO-1		12
WO-1		31

Steps 1-1 (FRAME)

Parts

A0		2
IO		2
J0		2
X0-1	 6-35  4mm	8

Tools

Z0-1	 4mm	1
Z0-2	 4mm	1

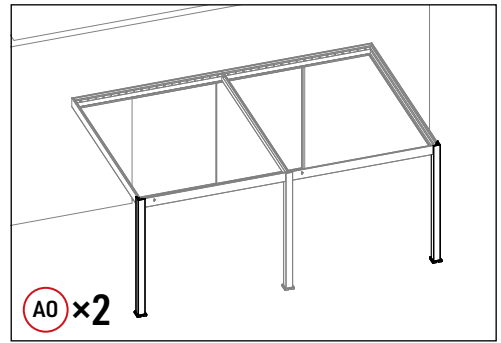

Completion Diagram

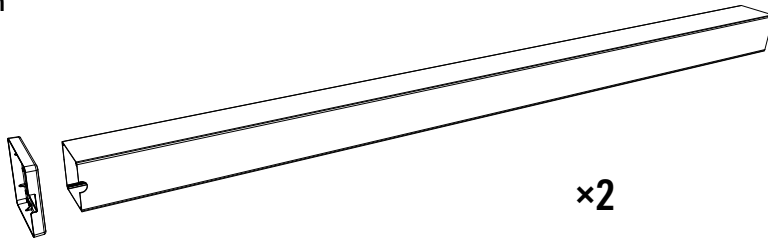

1

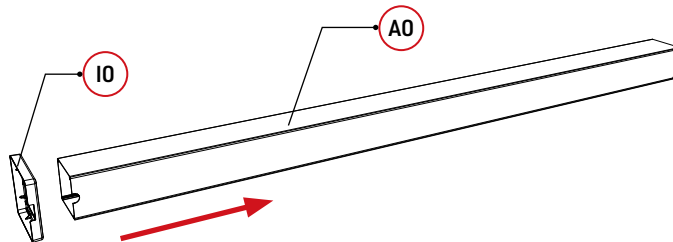

1. Place the **IO** into the **A0**, making sure that the notch around the column **IO** is aligned with the drain outlet at the bottom of the **A0** column, and place it into the column.



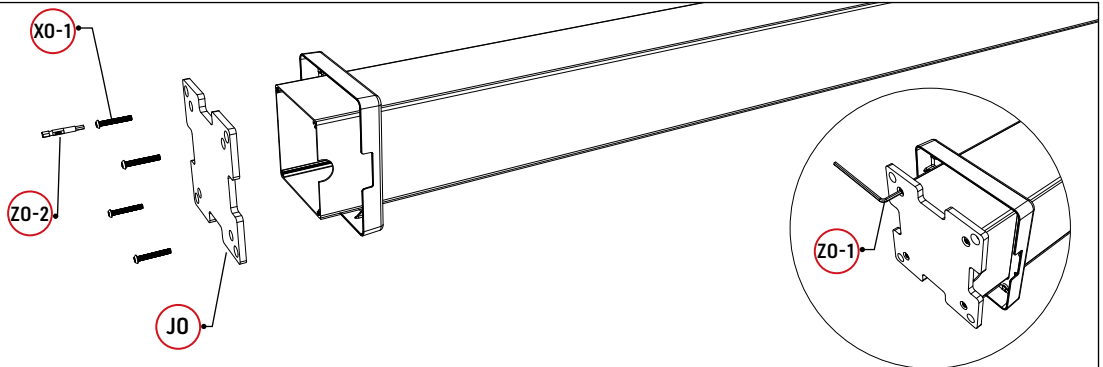

2





2. Use **X0-1** to connect the **J0** base plate to the bottom of the column, and use the hexagonal wrench **Z0-1** to tighten the screws manually.

Steps 1-2(FRAME)

Parts

A0-1		1
IO		1
J0		1
X0-1	 6x35 4mm	4

Tools

Z0-1	 4mm	1
Z0-2	 4mm	1

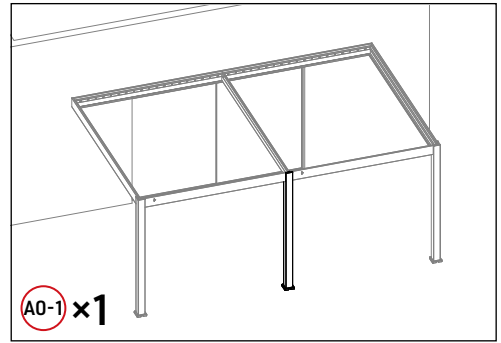

Completion Diagram

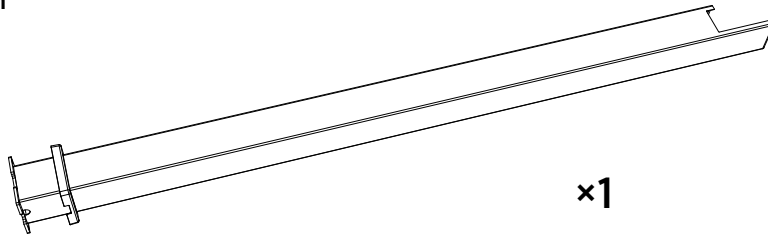

1

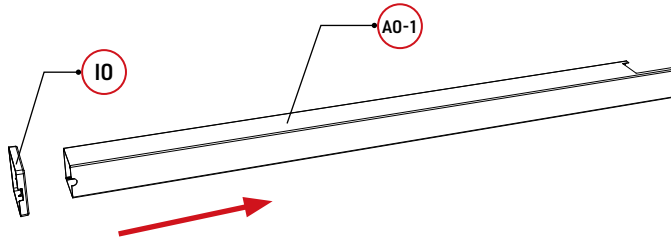

1. Place the **IO** into the **A0**, making sure that the notch around the column **IO** is aligned with the drain outlet at the bottom of the **A0** column, and place it into the column.

2

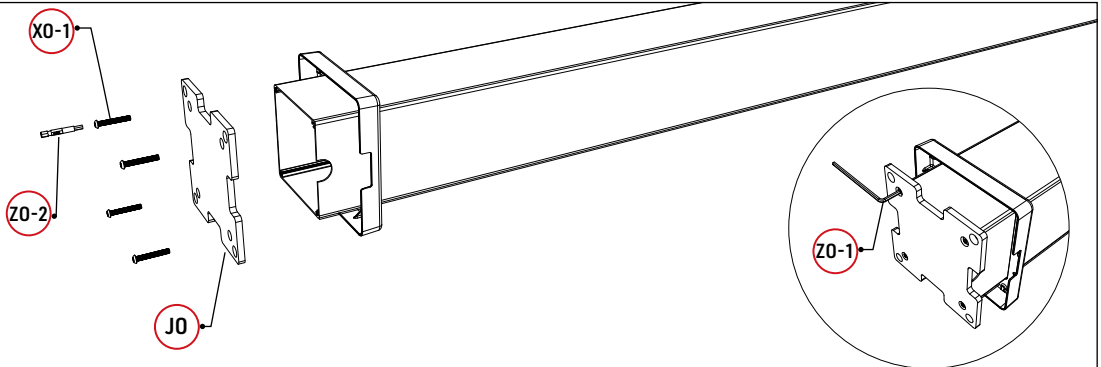

2. Use **X0-1** to connect the **J0** base plate to the bottom of the column, and use the hexagonal wrench **Z0-1** to tighten the screws manually.

Steps 1-3(FRAME)

Parts

B0-1		1
B0-2		1

E0-4		2	W0-1		20
E0-5		1			

Tools

Z0-7		1
------	--	---

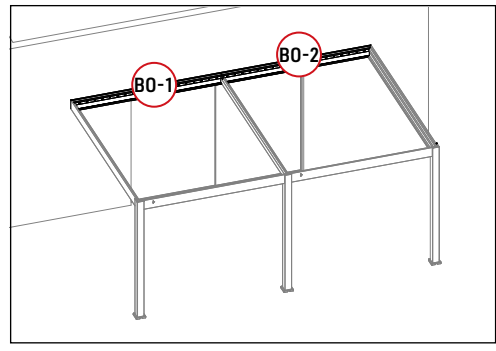

Completion Diagram

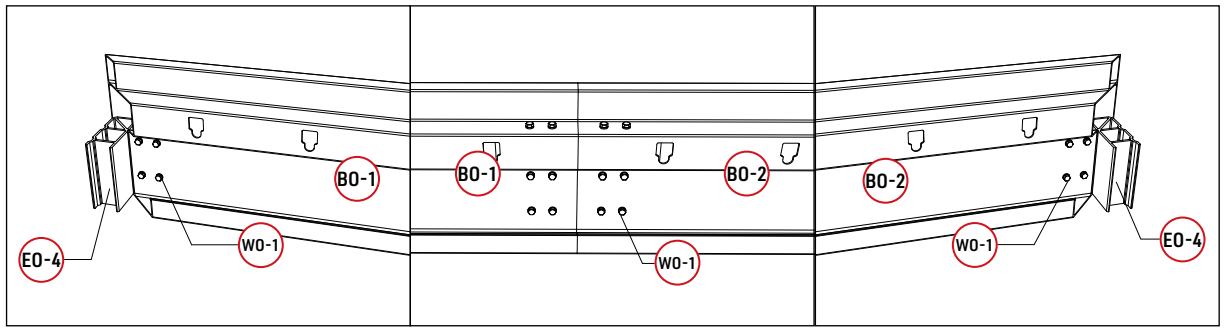
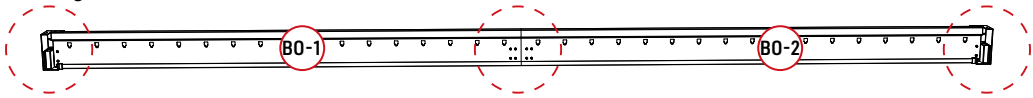

1. Put **E0-5** into the cavity of **B0-1** and fix it with **W0-1**, Connect **B0-2** to **B0-1** and fix it with **W0-1**.

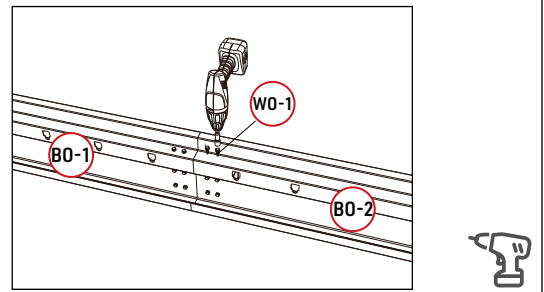
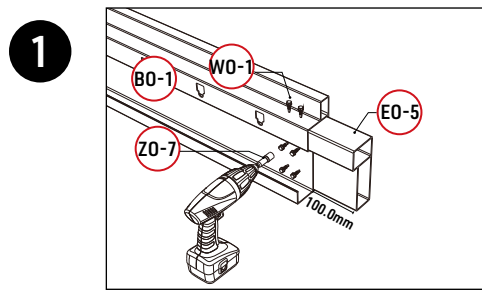

2. Place **E0-4** on both sides of **B0-1** & **B0-2**, and then use **Z0-7** to fix **E0-4** and **B0-1** with **W0-1**. Place **E0-3** on both sides of **B0-1** & **B0-2**.

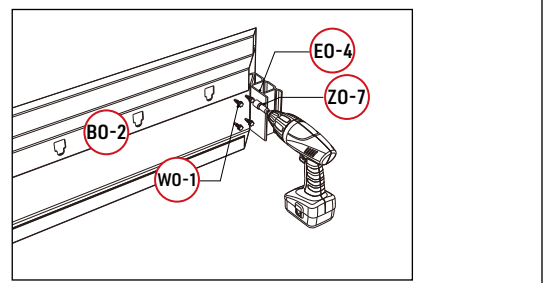
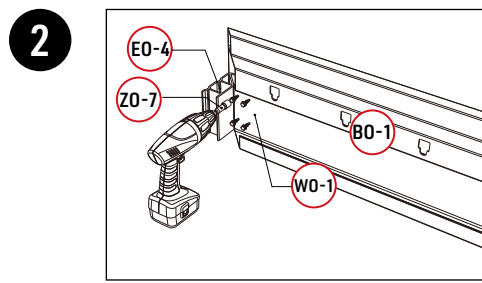

Steps 1-4(FRAME)

Parts

T0-1		12
------	---	----

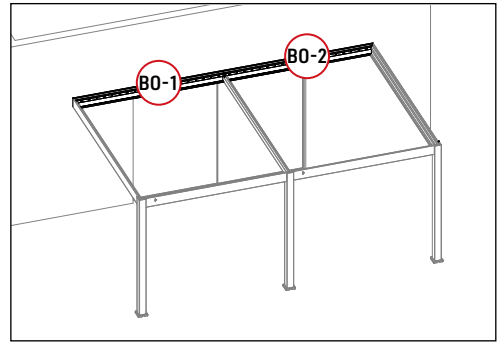

1. Place the bottom of **BO-1&BO-2** at a height of **2370** and keep it level.

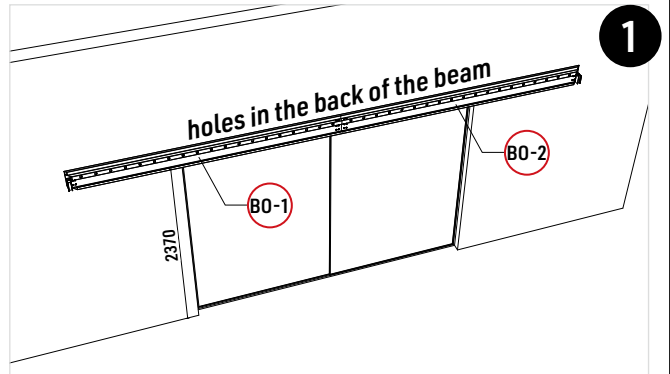
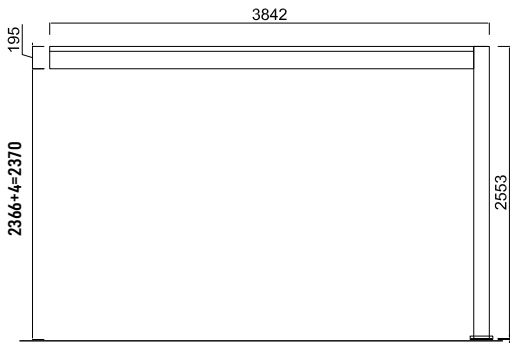

2. Use a marker to find the location of the hole on the back of **BO-1&BO-2** and mark it. Use an **M8×150 impact drill** to drill the hole.

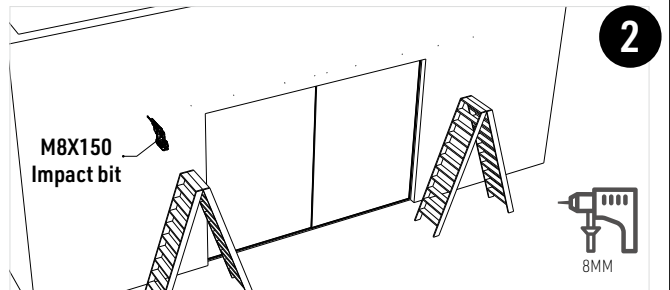
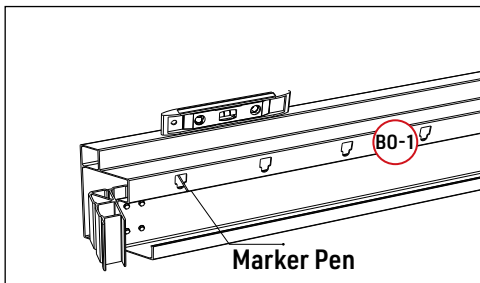

3. Pass the expansion screw **T0-1** through **BO-1** and fix **BO-1** to the wall.

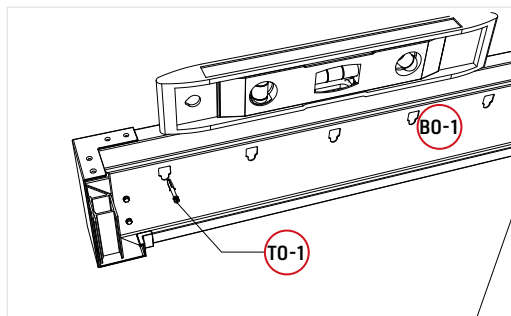

Steps 1-5(FRAME)

Parts

CO-1		1			
CO-2		1			
QO		4	QO-2		4
QO-1		4	QO-3		4
			WO-1		8

Tools

ZO-3		1
ZO-4		1
ZO-7		1
ZO-8		1

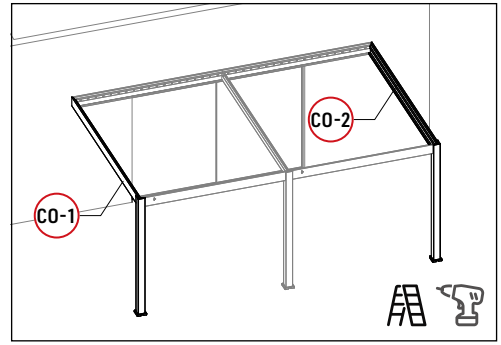

1. Connect **CO-1** to **AO**, and then insert the whole into **BO-1**.

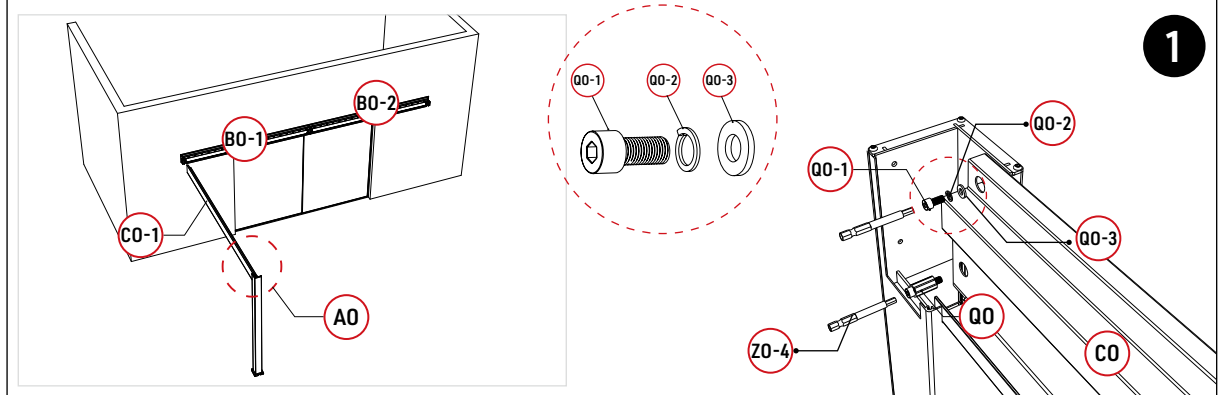

2. Use **WO-1** to fix **CO-1** on **BO-1**.

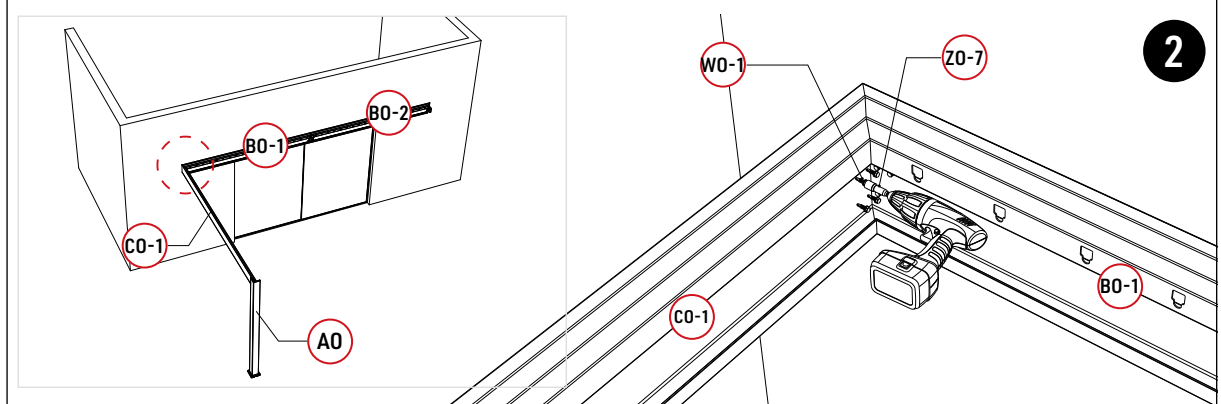

3. Repeat the above operation and fix **CO-2** on **BO-2** according to the same operation. use **ZO-3** to tighten manually. Apply glass glue **ZO-8** to the seams.

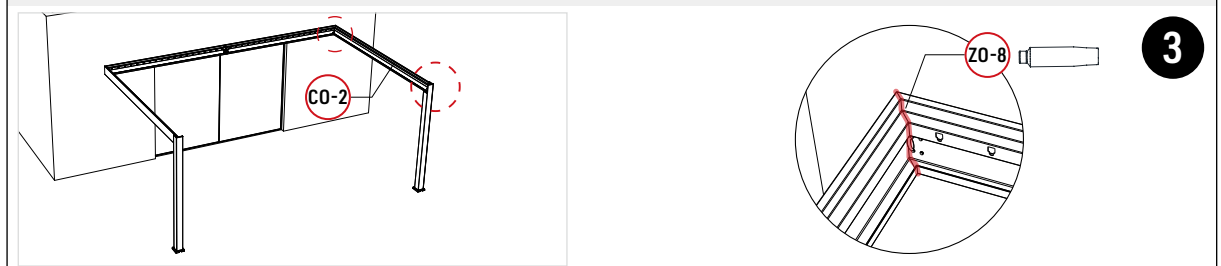

Steps 1-6(FRAME)

Parts

A0-1		1
B0		2
Q0		4
Q0-1		4
Q0-2		4
Q0-3		4
W0-1		8

Tools

Z0-3		1
Z0-4		1
Z0-7		1
Z0-8		1

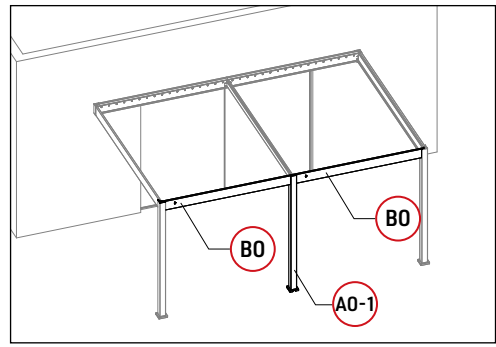

Completion Diagram

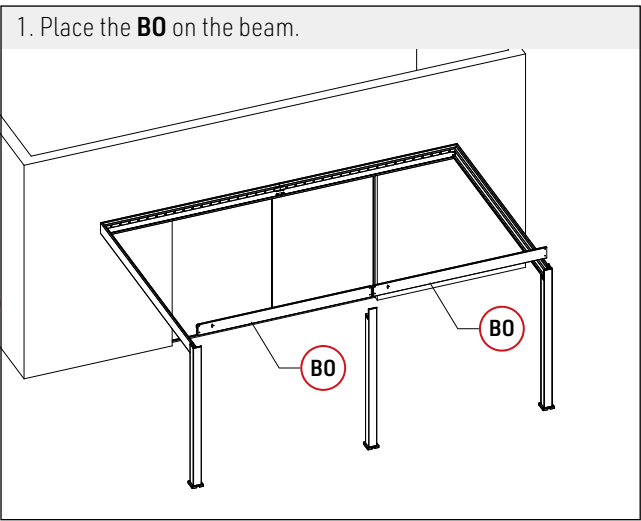
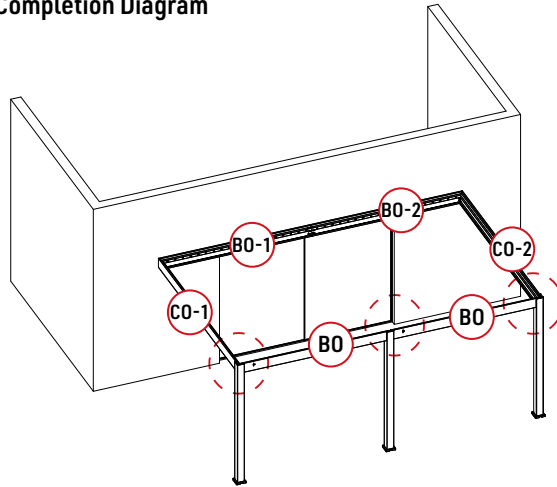



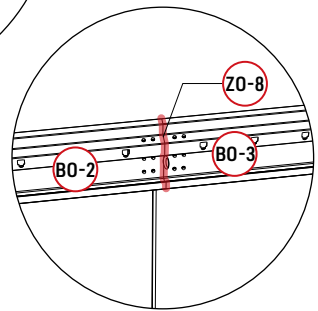
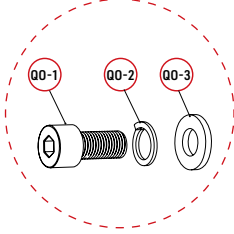
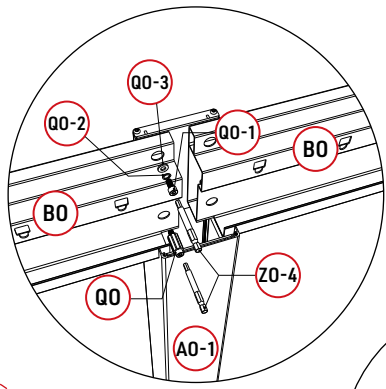
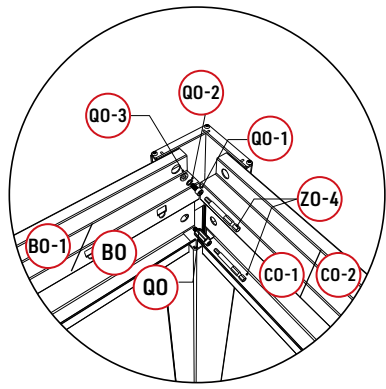



2. Connect **B0** to **C0-1** & **C0-2** at both ends as shown in the figure. Finally, use **Z0-3** to tighten manually. Apply glass glue **Z0-8** to the seams.





Steps 1-7(FRAME)

Parts

E0		1			
EO-1		1	XO-3		2
EO-2		1			
WO	 4x12 T20	2			
WO-1	 5x19	4			

Tools

ZO-1	 4mm	1
ZO-2	 4mm	1
ZO-7	 4mm	1

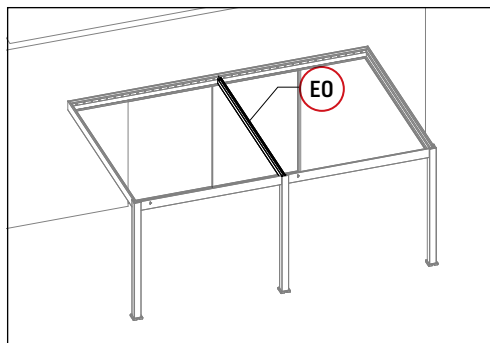

Completion Diagram

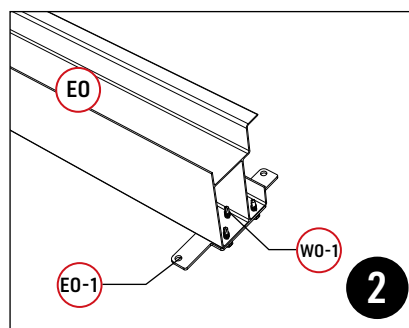
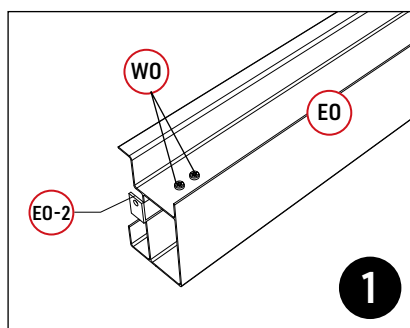
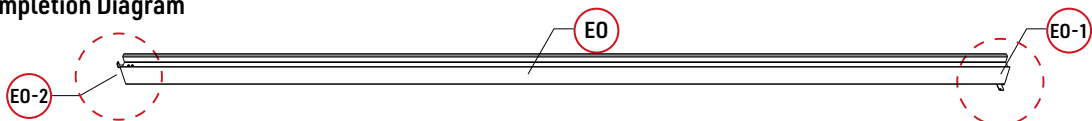

1. Fix **EO-2** on **EO**.

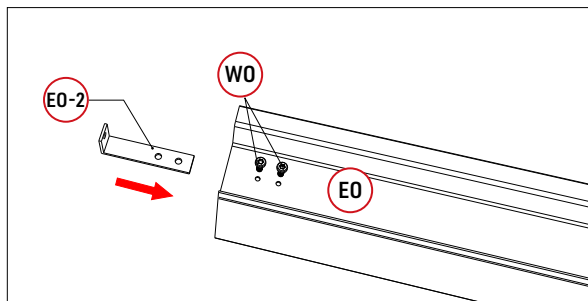

2. Fix **EO-1** on **EO**.

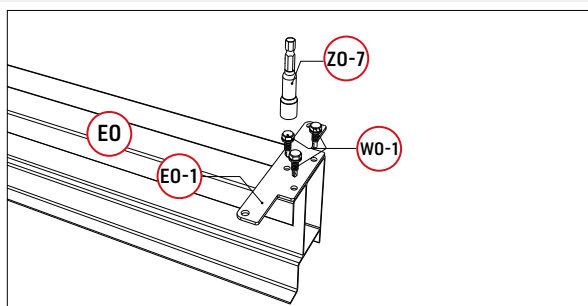

3. You need to pay attention to the direction of **EO** placement and place it according to the diagram.

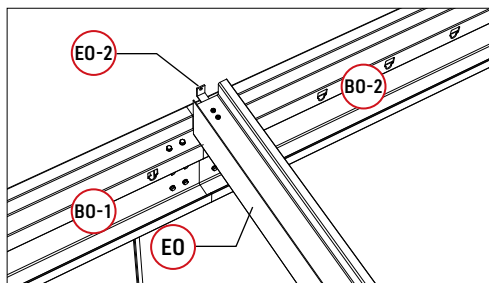
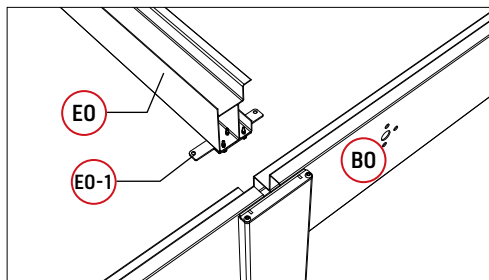
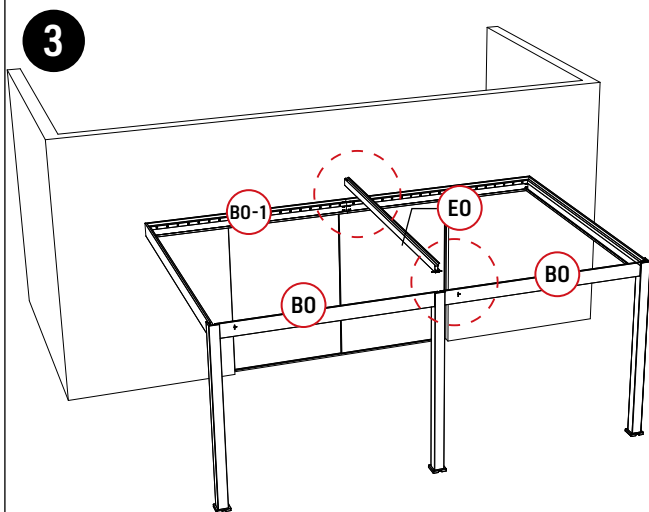

4. Use **XO-3** to fix **EO** to **AO-1**.

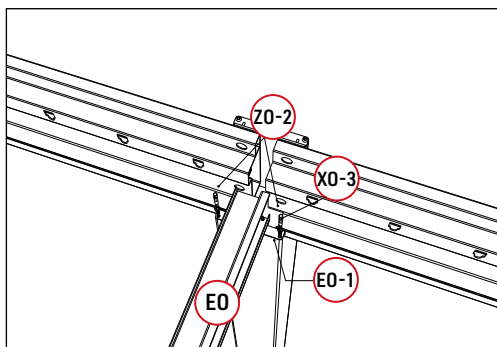
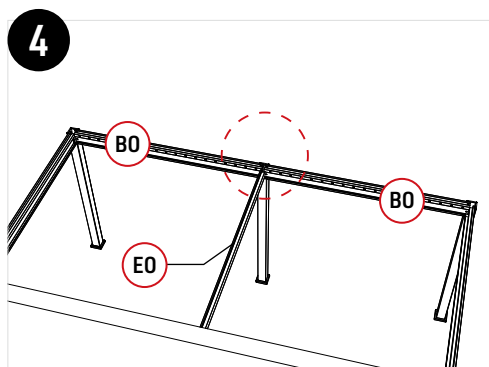

5. Use **WO-1** to fix **EO** to **AO-1**.

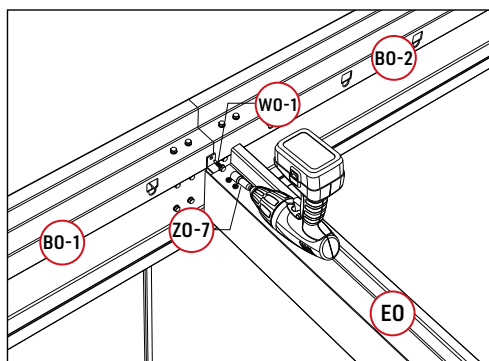
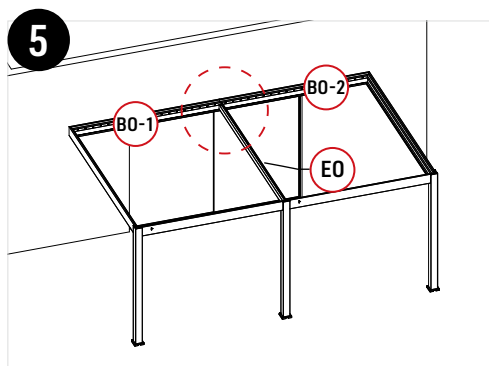



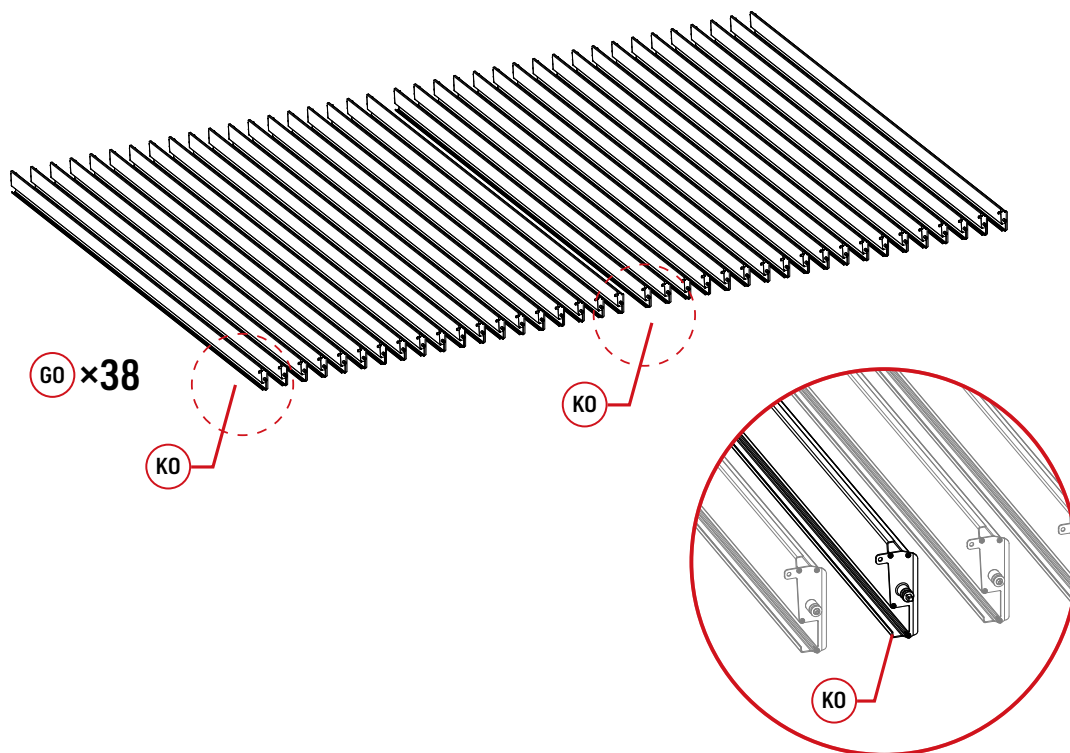



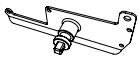
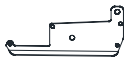

Steps 2-LOUVERS



PARTS







Reference	Parts	Quantity
GO		38

Reference	Parts	Quantity
KO		2
LO		36
LO-1		38
MO		74
MO-1		74



Reference	Parts	Quantity
VO		74
WO		304
UO		74
XO		74

Steps 2-1 (LOUVERS)

Parts

LO		36	UO	 lock nut	74
LO-1		38	VO		74
MO		74	XO	 6x40	74
MO-1		74			

Tools

ZO-1	 4mm	1
ZO-2	 4mm	1

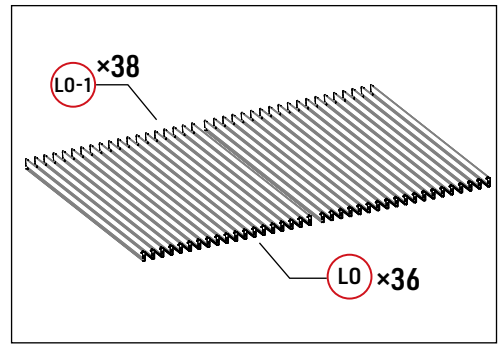

Completion Diagram

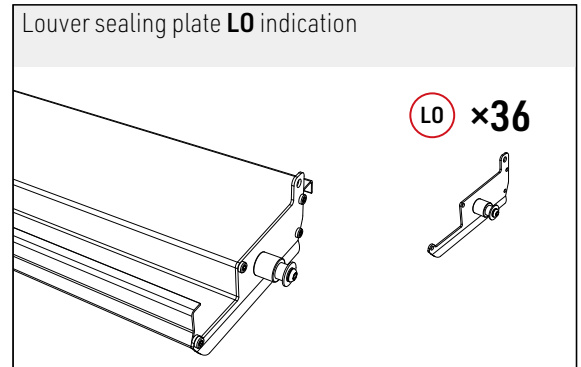
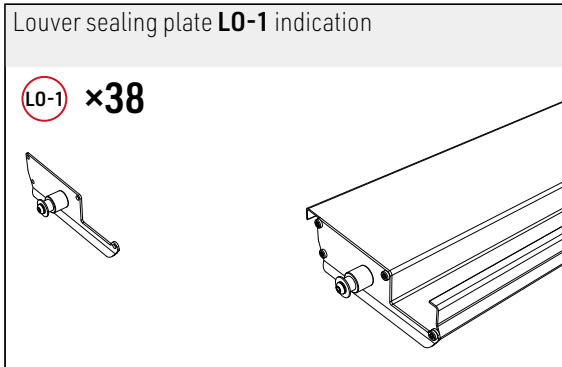

Complete the installation of accessories according to the instructions, then link the overall accessories to the **LO** sealing plate and tighten them with lock nuts.

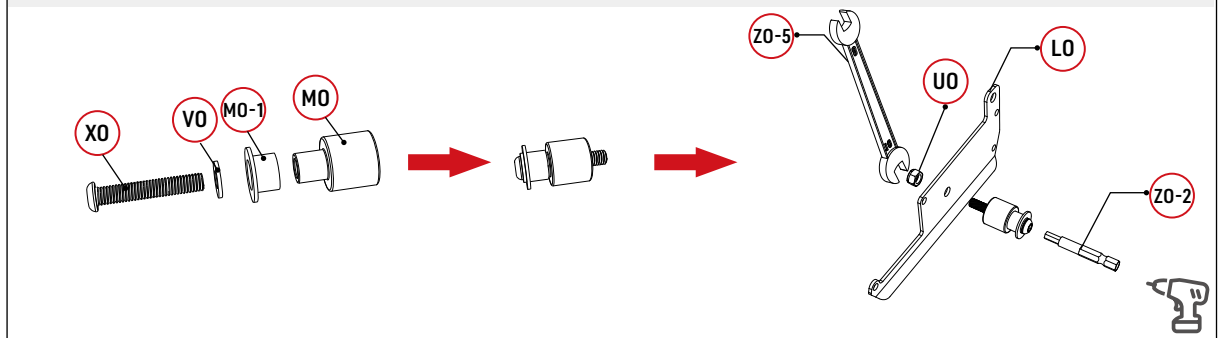

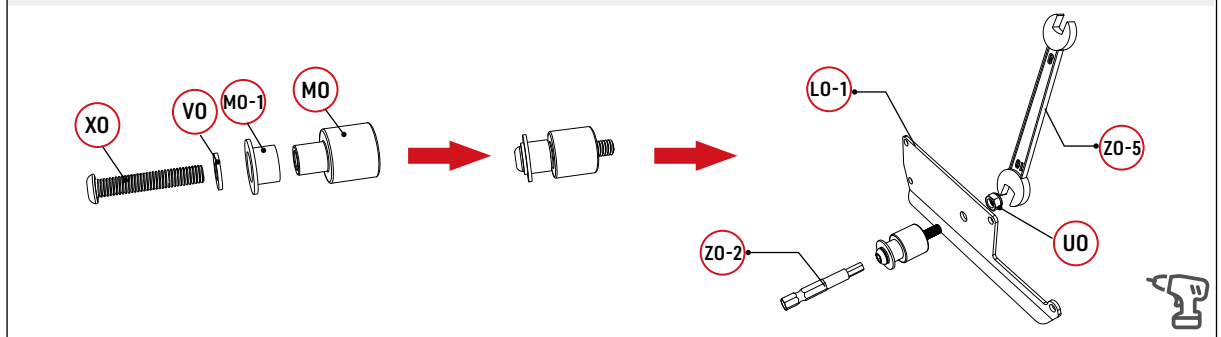

Complete the installation of accessories according to the instructions, then link the overall accessories to the **LO-1** sealing plate and tighten them with lock nuts.



Steps 2-2(LOUVERS)

Parts

KO		2
LO-1		2
WO		16

Tools

ZO-6		1
------	---	---

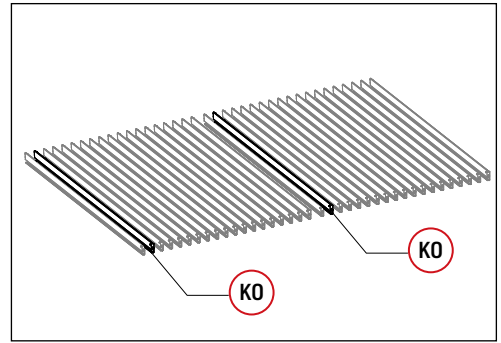

Completion Diagram

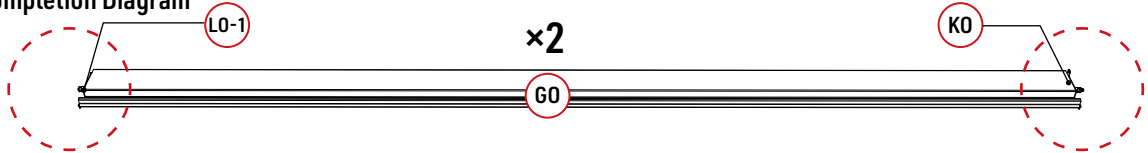

Use **ZO-6** with **WO** to lock **KO** on the blinds.

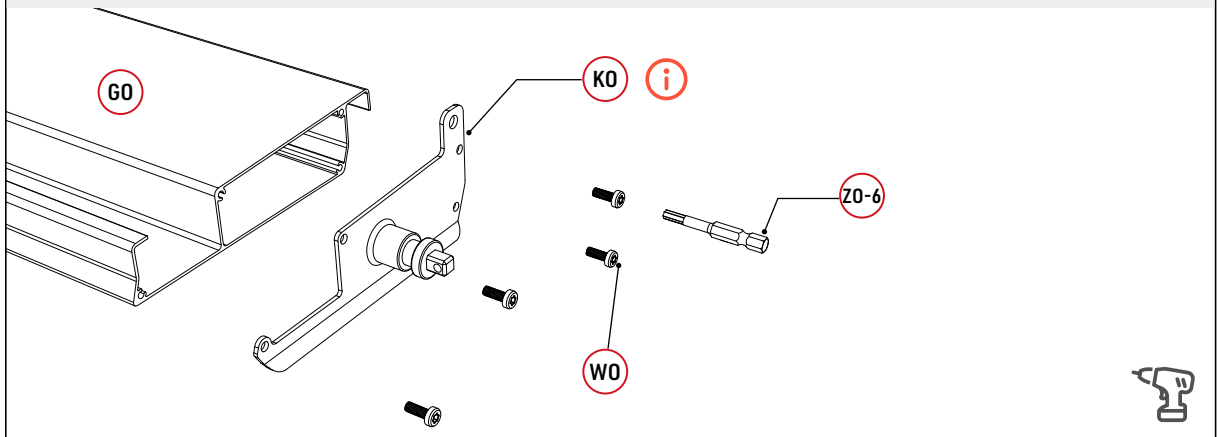

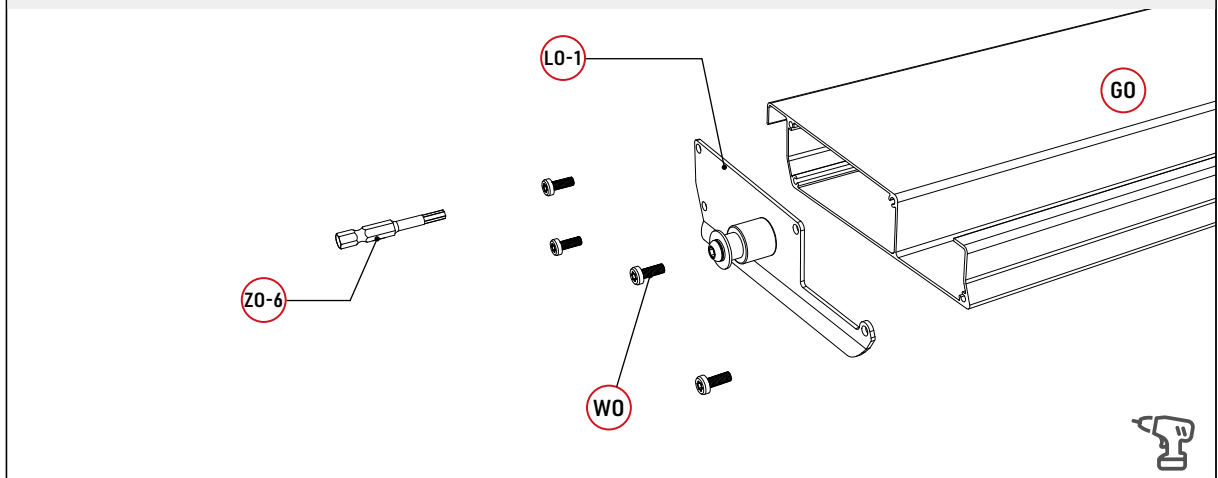

Use **ZO-6** with **WO** to lock **LO-1** on the blinds.



Steps 2-3(LOUVERS)

Parts

LO		36
LO-1		36
WO		288

Tools

ZO-6		1
------	---	---

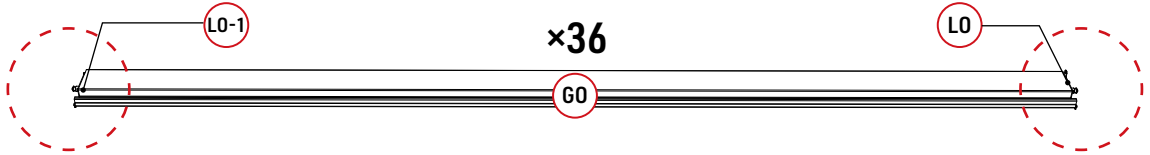
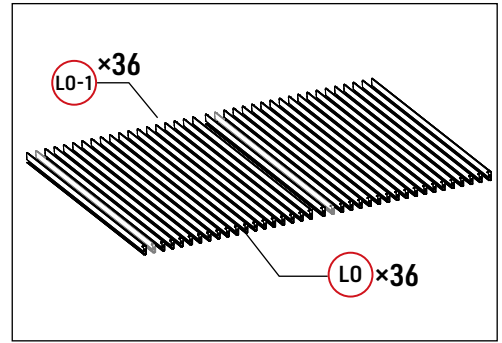

Use **ZO-6** with **WO** to lock **KO** on the blinds.

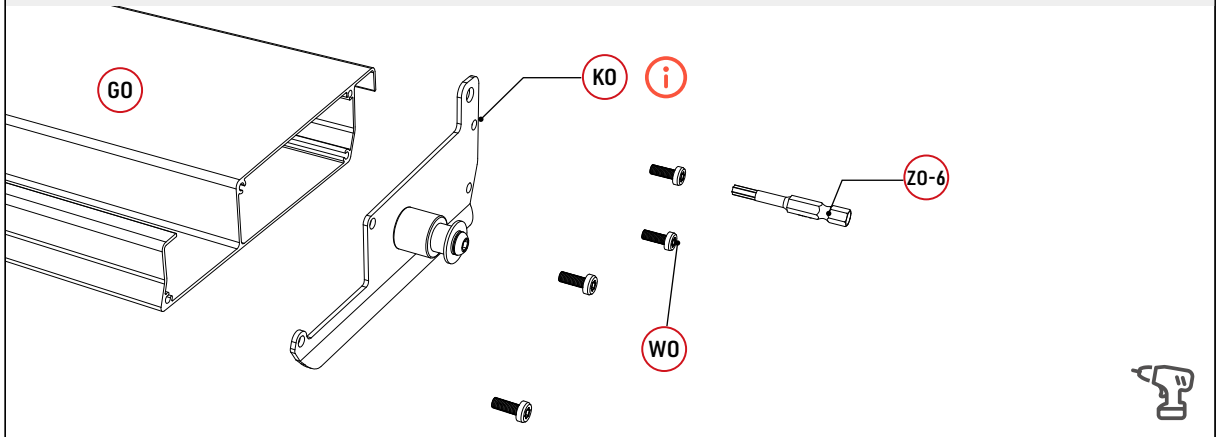

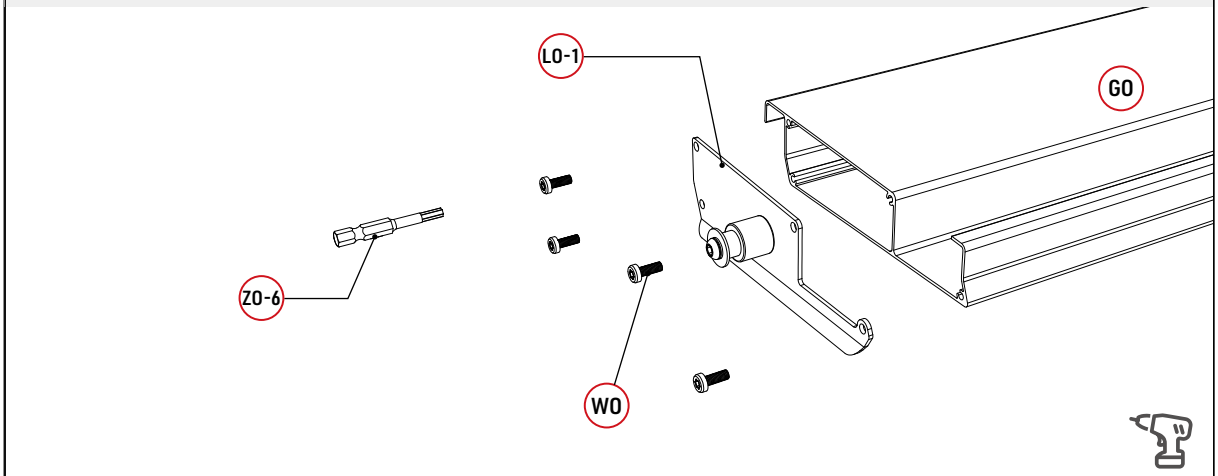

Use **ZO-6** with **WO** to lock **LO-1** on the blinds.



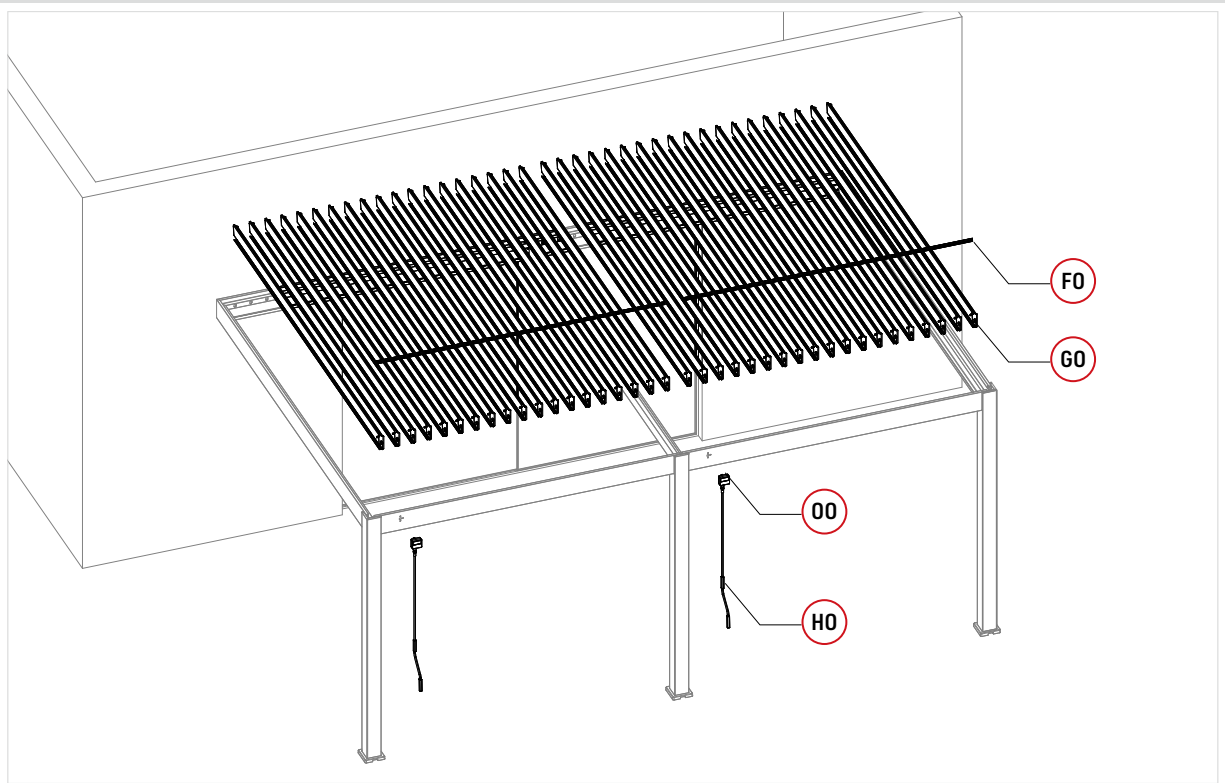





Steps 3-CONNECTORS

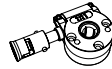

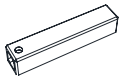
PARTS

Reference	Parts	Quantity
FO		2
HO		2

Reference	Parts	Quantity
NO		2
OO		2
PO		2
RO		12
SO		76

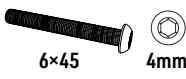
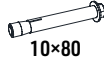
Reference	Parts	Quantity
VO		114
YO		6
TO		12

Steps 3-1 (CONNECTORS)

Parts

SO		76
----	---	----

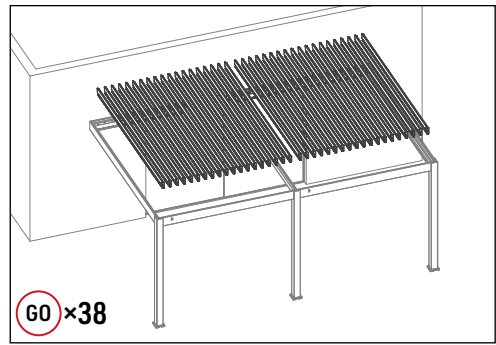

Completion Diagram

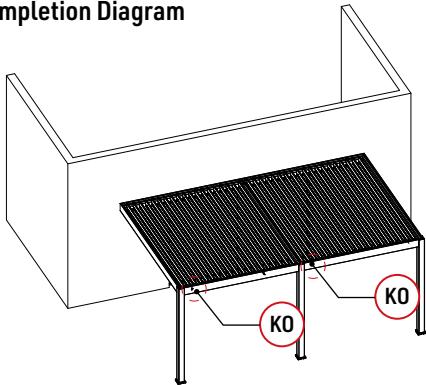

Place the louvers with integrated cap (main louvre) on the beam first.

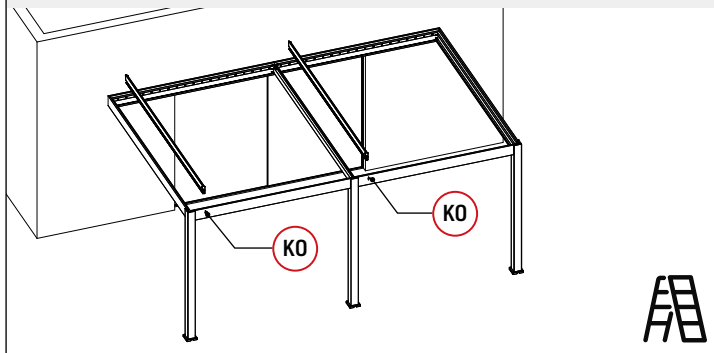

First, push the louver near the **B0** section into the hole.

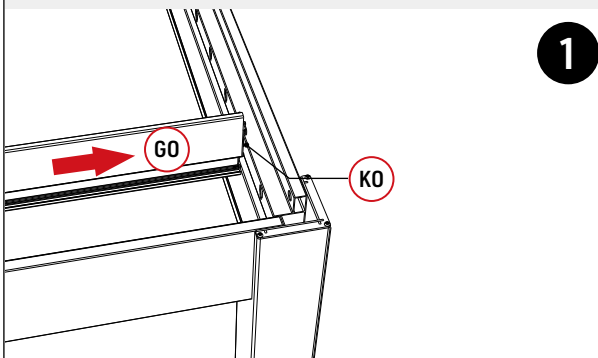

Then put another section into the hole on the side of **B0-1**.

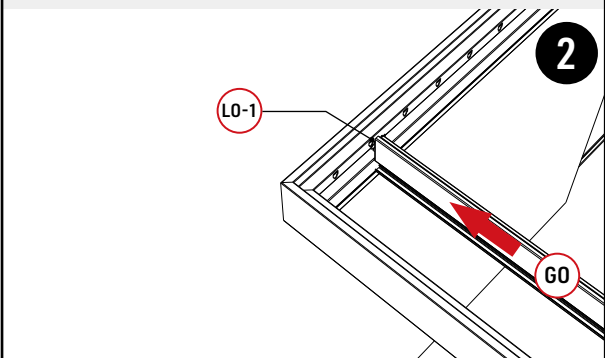

Cover both ends of the louver with **SO**

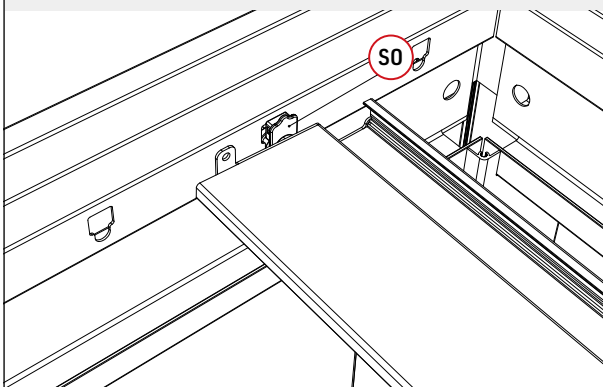



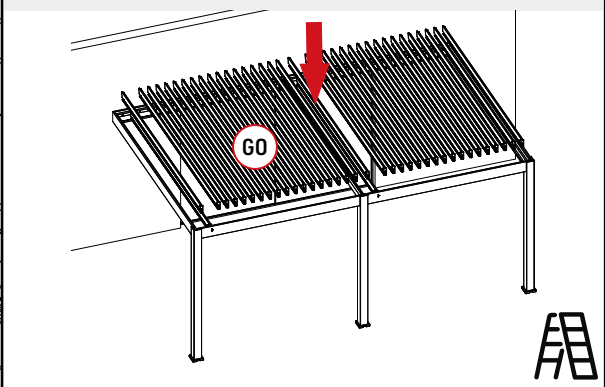

Repeat the above steps to install the louver





Steps 3-2(CONNECTORS)

Parts

HO		2
NO		2
OO		2
PO		2

Tools

ZO-1	 4mm	1
ZO-2	 4mm	1

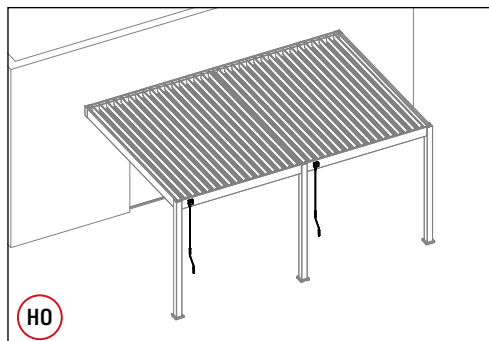

Completion Diagram

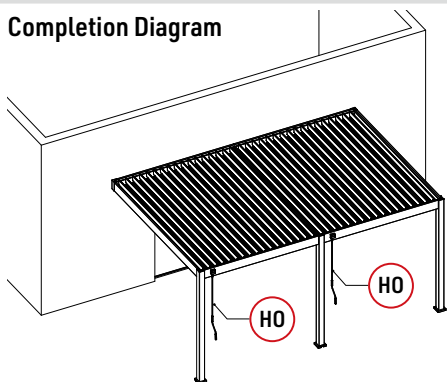

1. Insert the **PO** spindle into the hole.

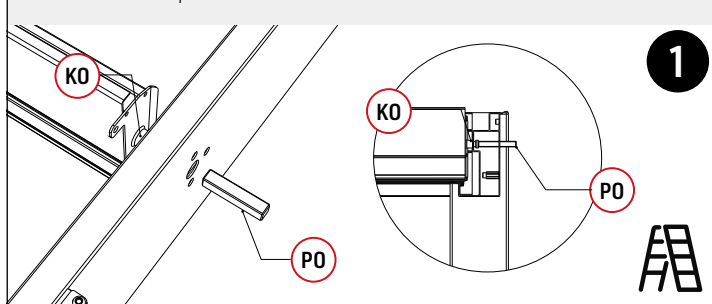

2. Place **OO** first, then assemble **NO**, after that, fix it with **YO**.

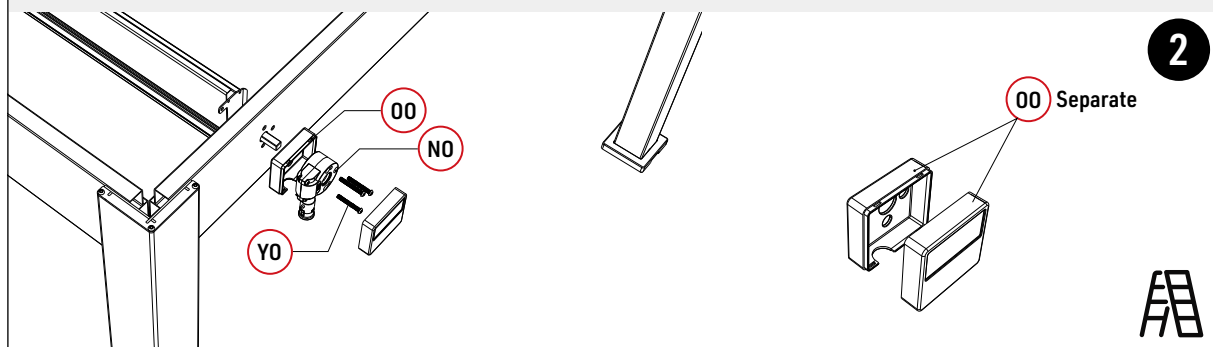



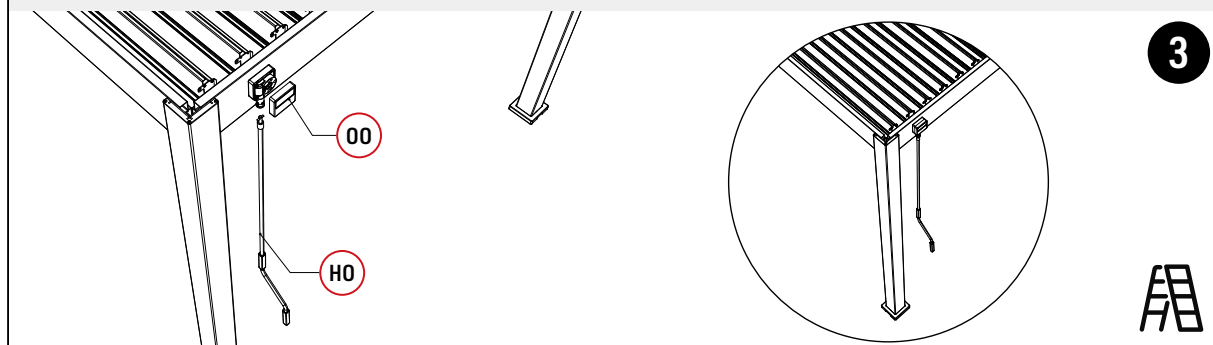



3. Fasten **NO**, assemble **HO** and rotate the louvers to 90 degrees.





Steps 3-3(CONNECTORS)

Parts

FO			2
UO		38	XO-2  6*20  4mm 38
UO-1		38	
VO		114	

Tools

ZO-1		1
ZO-2		1

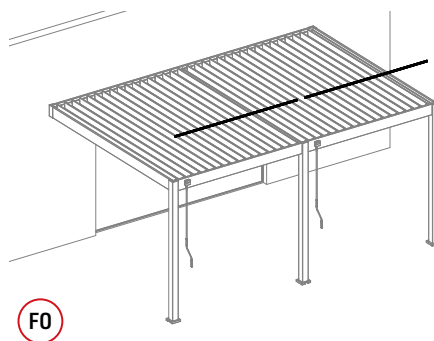

1. First use **XO-2** to pass through the two pieces of **VO**, and use **UO-1** to fix it on louvre cap.

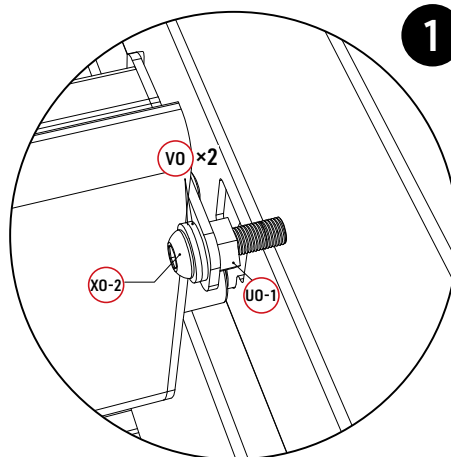
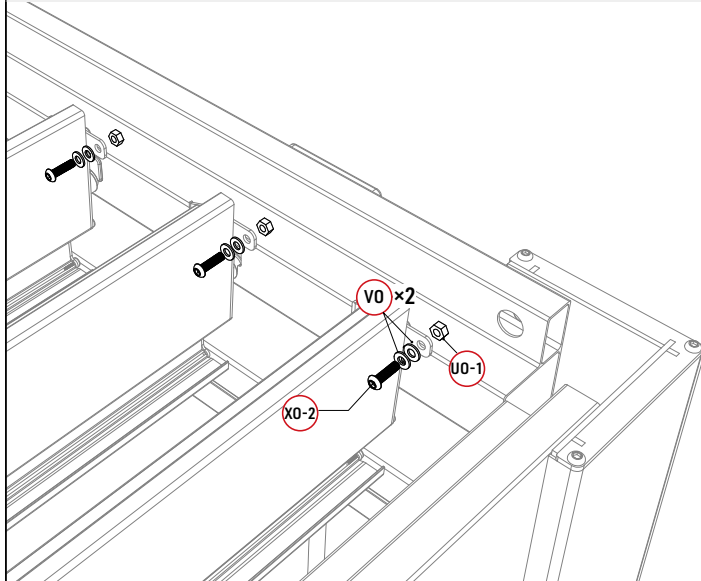

2. Connect **FO**, use **VO** and **UO** to fix

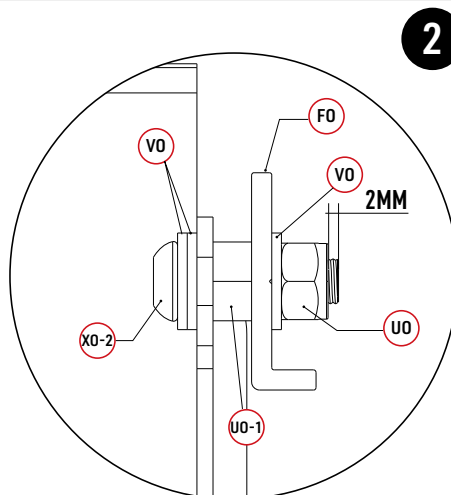
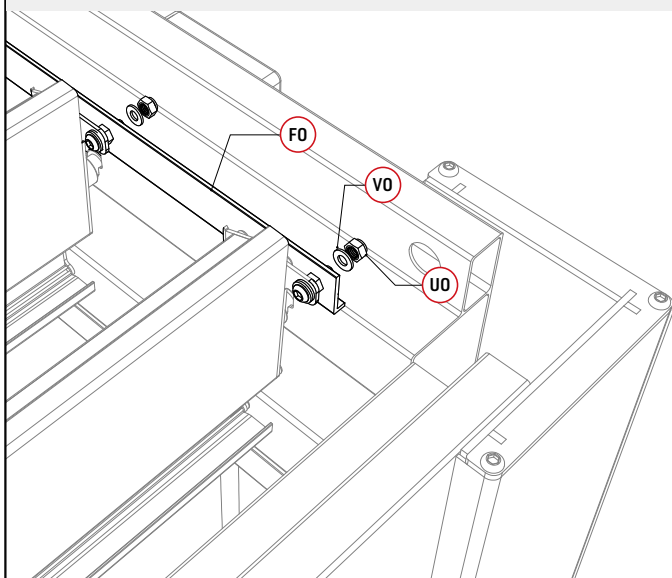

Steps 3-4(CONNECTORS)

Parts

RO		12	T0		12
----	---	----	----	---	----

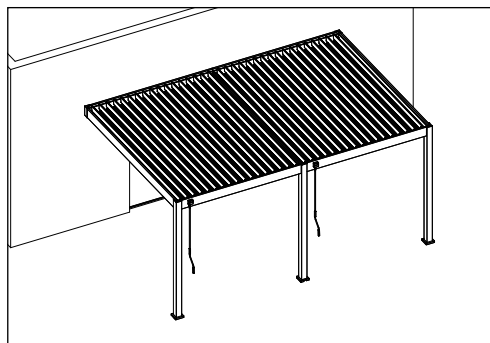

Use **RO** to seal beam end caps

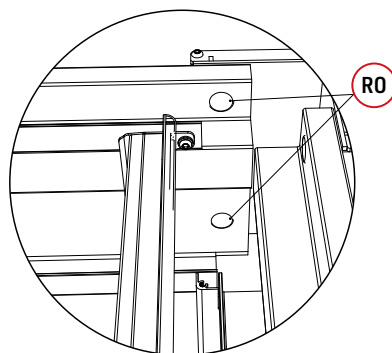
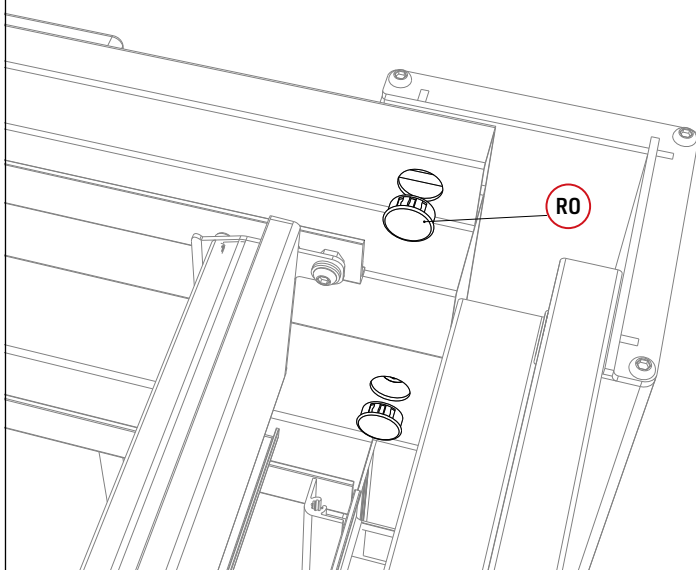

Check size .Use a **Ø12mm drill bit** to drill holes on the position where to fix the steel plate, then fix steel plate with **T0**. Use a M17 wrench to fasten the **T0**

