

# 3,6x4 Meter Pergola elektrisch, Aluminium, LED

Montageanleitung - DE

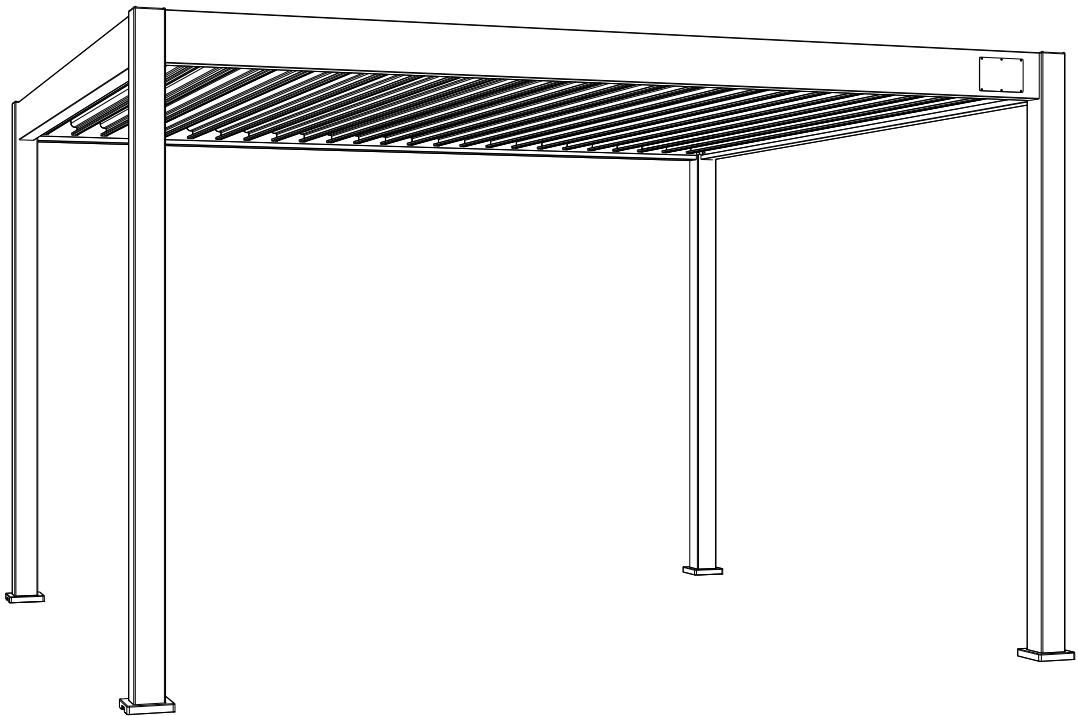
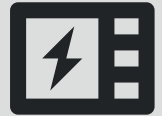

# E-Deluxe Aluminium Pergola 3,6×4 Meter

Bewahren Sie die Anleitung während der gesamten Lebensdauer des Produkts auf. Bitte lesen Sie die Anleitung vor dem Zusammenbau aufmerksam durch. Der Nutzer haftet für Schäden oder Verletzungen, die durch unsachgemäße Verwendung verursacht werden.

## Zusätzlich benötigte Werkzeuge und Sicherheitskleidung für die Installation (nicht enthalten)

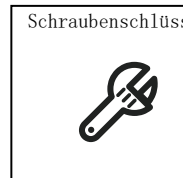
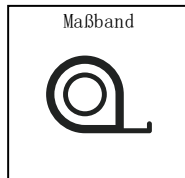
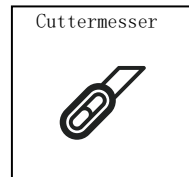
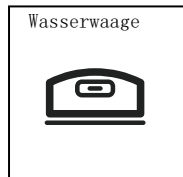
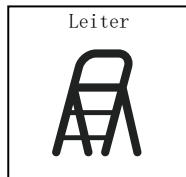

## 2D Fundamentmessung (Dimension in mm)

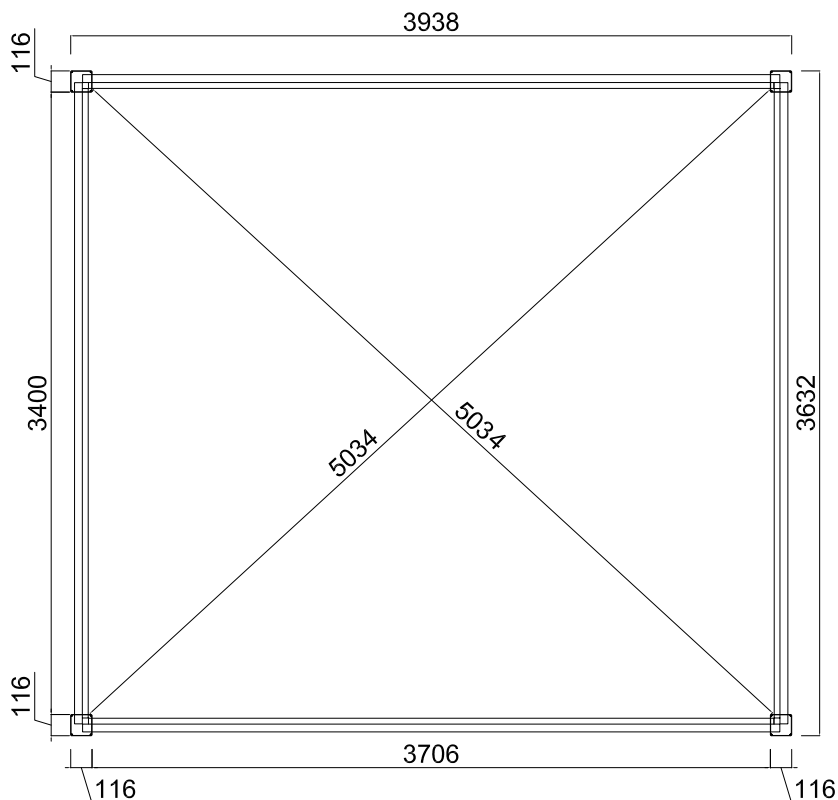

## 3D Fundamentmessung (Dimension in mm)

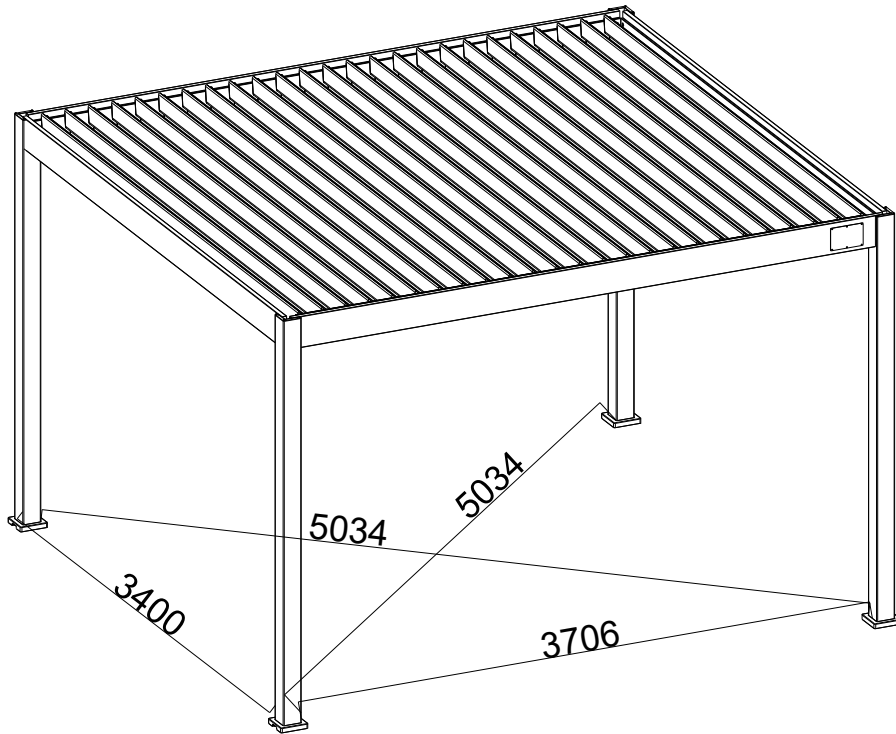

## VORSICHTSHINWEISE FÜR DEN GEBRAUCH

Dieses Produkt sollte nicht bei extremen Wetterbedingungen verwendet werden: Stürme, heftiger Wind, Hagel und Schnee. Wir garantieren die Beständigkeit der Pergola für Windgeschwindigkeiten bis zu 88 km/h und eine maximale Schneelast von 50 kg/m<sup>2</sup>.

Bei starkem Schneefall oder Wind, weisen wir ausdrücklich darauf hin die Lamellen zu öffnen. Bitte nicht vergessen, den Schnee vom Dach zu entfernen, um eine starke Überlastung vom Dach zu vermeiden.

Unsere Pergola kann starke Regenfälle standhalten, aber wir können keine absolute Wasserdichtigkeit garantieren. Bei außergewöhnlichen Wetterereignissen kann die Wasserdichtigkeit beeinträchtigt werden. Lassen Sie keine feuchtigkeitsempfindlichen Produkte unter der Pergola stehen.

Wir raten davon ab, auf das Dach oder das Gestell der Pergola zu klettern. Es besteht die Gefahr von Schäden und Verletzungen.

## Tipps und Sicherheitshinweise

Je nach Standort und Fläche kann es sein, dass für den Bau eine Baugenehmigung oder ein Antrag auf Baugenehmigung erforderlich ist. Wir empfehlen Ihnen vor dem Aufbau sich an Ihre Stadtverwaltung zu wenden, um die entsprechenden Informationen zu erhalten.

### Produktmontage:

- Es werden 2-3 Personen benötigt
- Entfernen Sie vor der Installation die Schutzfolie von allen Teilen
- Lassen Sie Kinder nicht in der Nähe des Montagebereichs spielen
- Achten Sie auf die Klemmgefahr
- Ziehen Sie die Schrauben nicht vollständig an, bevor Sie die entsprechenden Teile zusammen gebaut haben
- Alle Aufbauschnitte müssen genau befolgt werden
- Diagonalen und Auslotungen kontrollieren
- Befestigen Sie die Pergola erst nach dem Zusammenbau

Es dürfen keine Veränderungen am Produkt vorgenommen werden. Vom Benutzer abgeänderte Produkte, fallen nicht mehr unter die Garantie des Herstellers.

Der Standort sollte mit Bedacht gewählt sein. Es wird empfohlen, die Pergola nicht bei Regen, in der Hauptwindrichtung oder unter einem Baum aufzustellen. Die Pergola muss auf einem ausreichend stabilen und ebenen Fundament errichtet werden. Es wird empfohlen sie auf einer Betonplatte oder auf 25 x 25 cm großen Betonklötzen an jedem Pfosten zu errichten.

Wenn Sie Ihre Pergola in der Nähe Ihres Hauses oder eines Gebäudes montieren möchten, überprüfen Sie bitte das Vorhandensein von Regenrinnen für die Wasserableitung.

Falls diese Hinweise nicht oder nur teilweise befolgt werden, erlischt die Garantie des Verkäufers.

## Wartung

Eine regelmäßige Pflege des Produkts ist nötig um eine Langlebigkeit des Produkts zu gewährleisten.

Empfehlungen:

- Waschen Sie die Pergola 1–2-mal im Jahr mit Süßwasser und einem Schwamm oder Tuch. Verwenden Sie keine aggressiven Reinigungs- oder Scheuermittel.
- Überprüfen Sie regelmäßig (min 1x im Jahr) ob die Schrauben fest angezogen sind.
- Ölen Sie die Befestigungen regelmäßig (mindesten 1x pro Jahr)
- Achten Sie darauf, dass nichts den Wasserabfluss in den Regenrinnen behindert (Blätter, Äste)
- Entfernen Sie Wasser, das sich an den Füßen der Pergola herum sammelt (heben Sie die Abdeckungen an)

## Garantie

Die Garantie umfasst nicht:

- Normale Gebrauchsspuren des Produkts
- Verlust oder Bruch von Teilen beim Auspacken oder bei der Montage
- Mangel an vernünftiger Sorgfalt, Vernachlässigung, Vandalismus, Einwirkung fremder Gegenstände, Gewalt anwendung, Kontakt mit Schleifmittel, Ästhetik, Ausbau, Wiederaufbau oder Verlegung des Standorts.
- Höhere Gewalt: Hagel, starke Winde, Stürme, Schnee, Überschwemmungen, Blitzschlag...
- Veränderung des Produkts durch den Benutzer.

Die Garantie umfasst nur den Ersatz des Ersatzteils oder des gelieferten Produktes, unter Ausschluss jeglicher Kosten und Entschädigungen jeglicher Art. Die Garantie muss bei der Verkaufsstelle (Geschäft oder Internetseite) beantragt werden, bei der Sie Ihr Produkt gekauft haben.

## Teileliste pro Karton









Bevor Sie mit dem Aufbau beginnen, bitten wir Sie alle aufgeführten Bauteile auf Vollständigkeit zu prüfen. Zudem bitten wir Sie nachzuschauen, dass keine Schäden an den Teilen vorhanden sind. Fehlende oder beschädigte Teile müssen binnen 10 Werktagen beim Hersteller reklamiert werden nach Anlieferung der Ware.



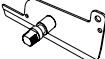
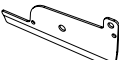



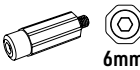

Sie können hierzu gerne unseren Kundenservice kontaktieren.

Entsorgen Sie die Verpackung nicht, ohne sicherzustellen, dass das Produkt richtig funktioniert.



# KARTON 1/5 (Pfosten und lose Teile)



Referenz	Teile	Menge
A0		4

Referenz	Teile	Menge
I0		4
J0		4
K0		1
L0		24
LO-1		25
M0		49
MO-1		49
Q0		16
RO		16
SO		50



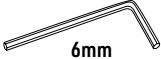

Referenz	Teile	Menge
T0	 10x80	16
U0	 lock nut	74
U0-1	 plastic nut	25
U0-3	 M14	1
V0		124
W0	 4x16 PH2	100
X0	 6x40 4mm	49
X0-1	 6x35 4mm	16
X0-2	 6x20 4mm	25

# KARTON 1/5 (Pfosten und lose Teile)



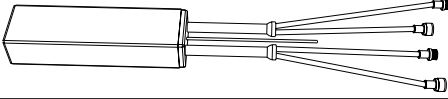

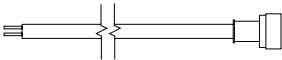
Referenz	Teile	Menge
ZO-1	 4mm	1
ZO-2	 4mm	1
ZO-3	 6mm	1

Referenz	Teile	Menge
ZO-4	 6mm	1
ZO-5	 10mm	1
ZO-6	 PH2	1

## Elektrische Produkte

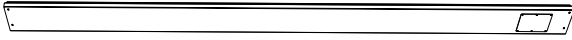
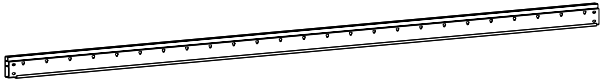
Referenz	Teile	Menge
E-C	Controller 	1
E-R	Fernbedienung 	1
E-P	Netzkabel(M15) 	1
E-W2	Wasserdichtes Gelenk(2) 	1
E-W3	Wasserdichtes Gelenk(3) 	1

# KARTON 2/5 (Balken)

Referenz	Teile	Menge
B1	 *Motor innen	1
BO-1		1
CO		1
CO-1		1
FO		1



**VORSICHT!**

**Verbindungsstange (FO) und Bürste im Inneren!**

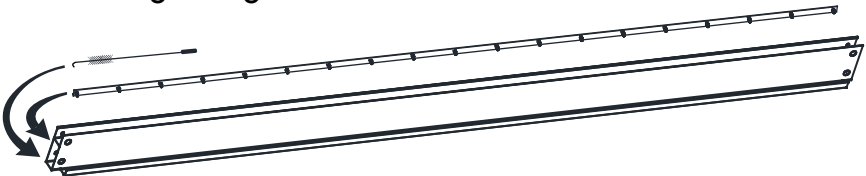



## Elektrische Produkte

E-T	 <p><b>Transformator</b></p>	1
-----	--	---

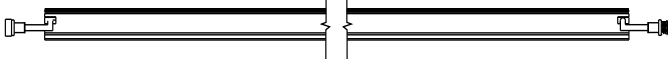
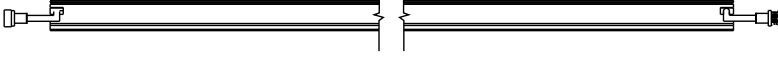

## KARTON 2/5 (Balken)

### LED products

Referenz	Teile	Menge
LED1		2
LED2		2
L-B		1

## KARTON 3/5 (Lamellen)

Referenz	Teile	Menge
GO		9

## KARTON 4/5 (Lamellen)

Referenz	Teile	Menge
GO		9

## KARTON 5/5 (Lamellen)

Referenz	Teile	Menge
GO		7

## Montageanleitung

Schritt 1: Rahmen & Motor

Schritt 2: Lamellen

Schritt 3: Verbindungen

# Schritt 1: Rahmen & Motor

Hinweise:

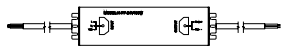

1. Bitte setzen Sie den Transformator in den Seitenbalken ein, der nahe am Motor ist.
2. Führen Sie das Eingangskabel des Transformators durch den Pfosten und ziehen Sie dann das Kabel aus der Kerbe an der Basis des Pfostens, um die Stromversorgung anzuschließen.
3. Bitte schließen Sie die Verkabelung gemäß dem untenstehenden Diagramm an.

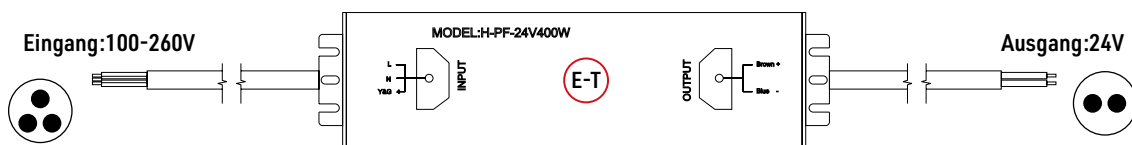
E-T	 <b>Transformator</b>	1
-----	---	---

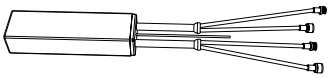

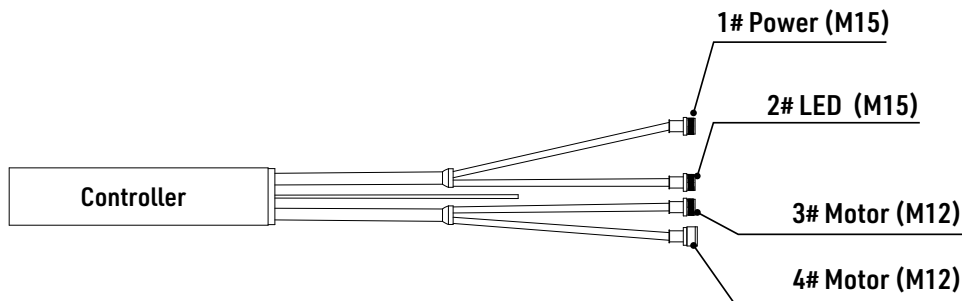
E-C	 <b>Controller</b>	1
-----	--	---

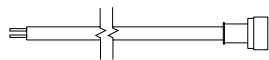

E-P		1
E-W2		1
E-W3		1

# Schritt 1: Rahmen & Motor

Motor, Controller und Transformator  
Platzierung in der Pergola

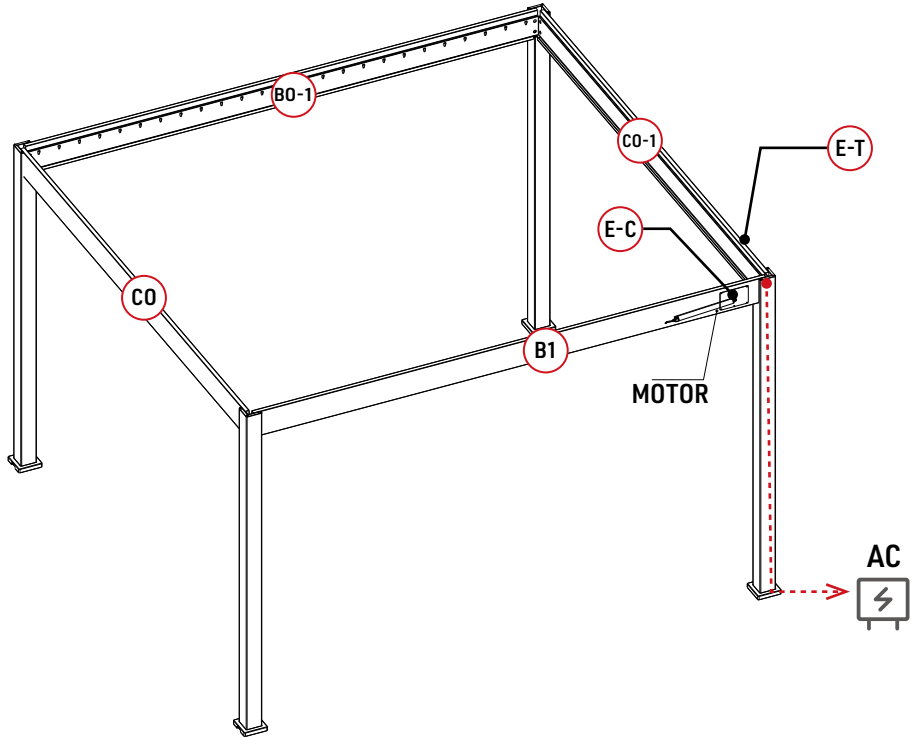



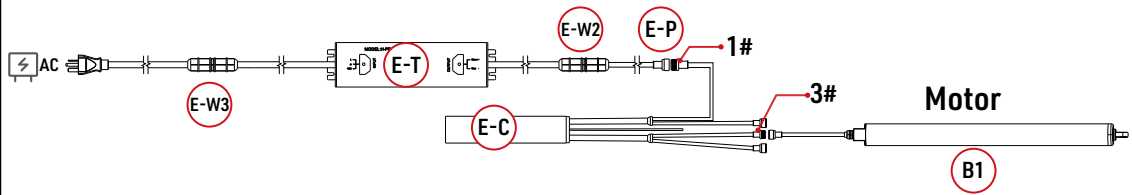

Schaltplan



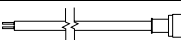

# Schritt 1: Rahmen & Motor 1-1

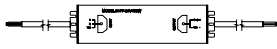
## Teile

A0		4			
E-P		1			
IO		4	X0-1		16
JO		4			
E-T		1			

## Werkzeuge

Z0-1		1
Z0-2		1



A0 x4

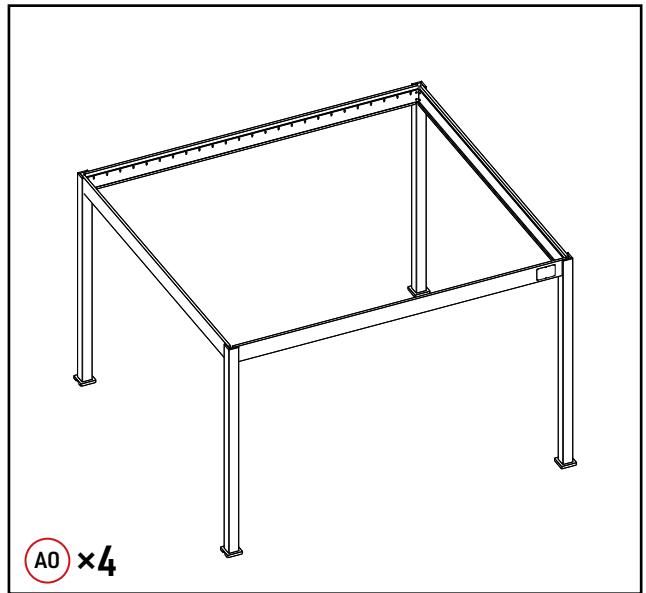

Bitte verbinden Sie die Ausgangsleitung (E-T) mit dem Stromkabel (E-P) des Transformators, indem Sie die wasserdichten Punkte (E-W2) verwenden.

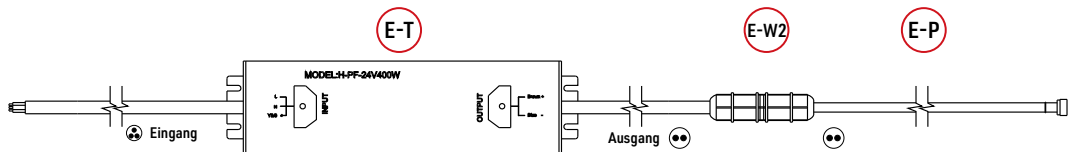

1. Bitte setzen Sie die Eingangsleitung des Transformators in die Höhlung des Pfostens ein.
2. Ziehen Sie die Eingangsleitung aus dem Entwässerungsauslass des Pfostens.
3. Installieren Sie die Platte des Pfostens, nachdem Sie die Eingangsleitung herausgezogen

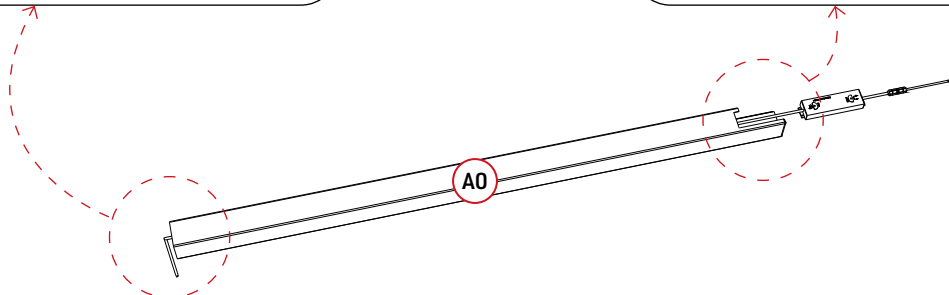
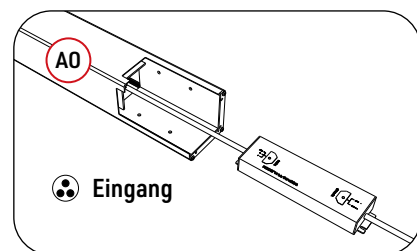
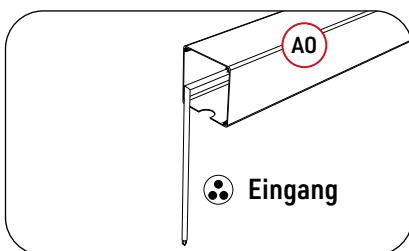

Setzen Sie bitte die Abdeckungsplatte (IO) auf den Pfosten (A0). Bitte beachten Sie, dass die Kerbe an der Abdeckungsplatte und der Entwässerungsauslass des Pfostens gemäß dem untenstehenden Diagramm ausgerichtet sein sollten.

1.

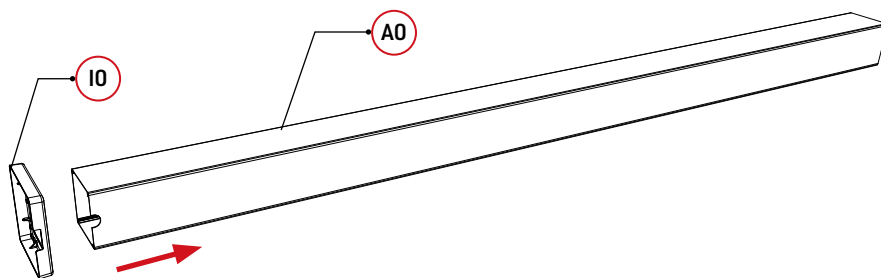

2. Installieren Sie die Platte.

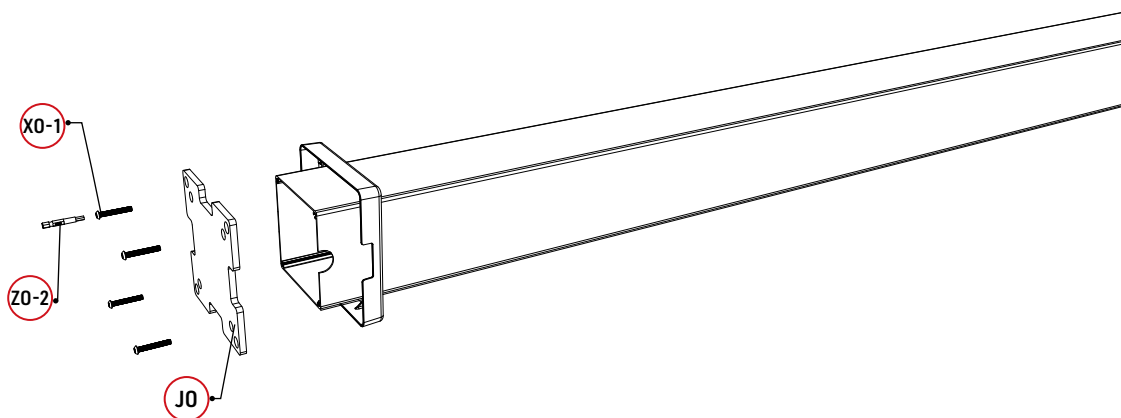

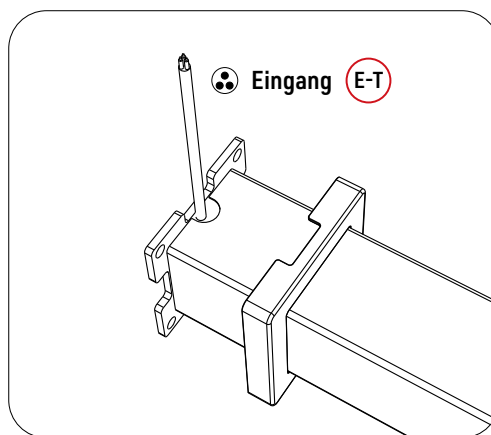
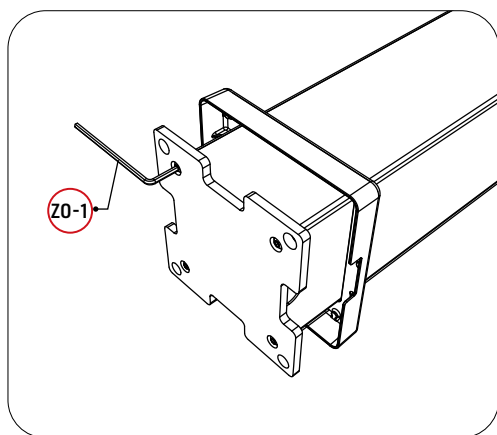

Verwenden Sie den Akkuschauber, um Schrauben auf der Platte zu befestigen, und ziehen Sie dann die Schrauben mit dem Schraubenschlüssel fest.

3. Spannen



## Schritt 1: Rahmen & Motor 1-2

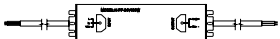

### Teile

CO		1
CO-1		1

E-T	 Transformator	1
-----	--	---

Q0	 6mm	8
----	---	---

### Werkzeuge

Z0-3	 6mm	1
Z0-4	 6mm	1

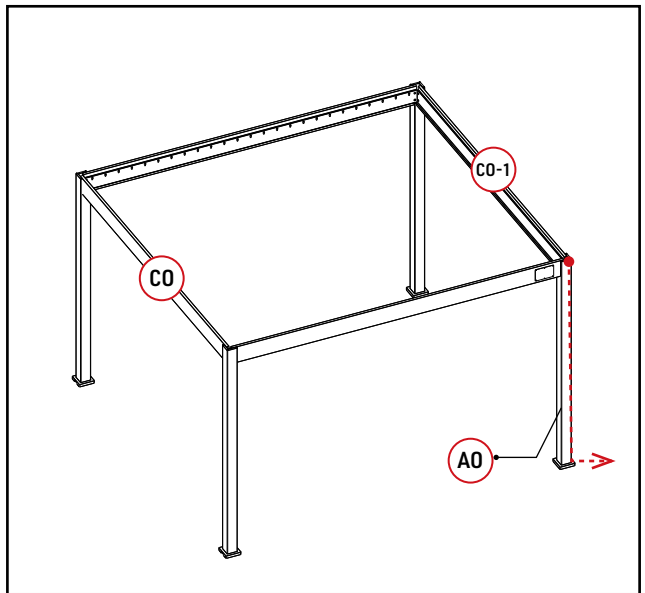

Setzen Sie den Transformator in die Höhlung von CO-1 ein und achten Sie darauf, genügend Länge des Stromkabels (E-P) zu reservieren.

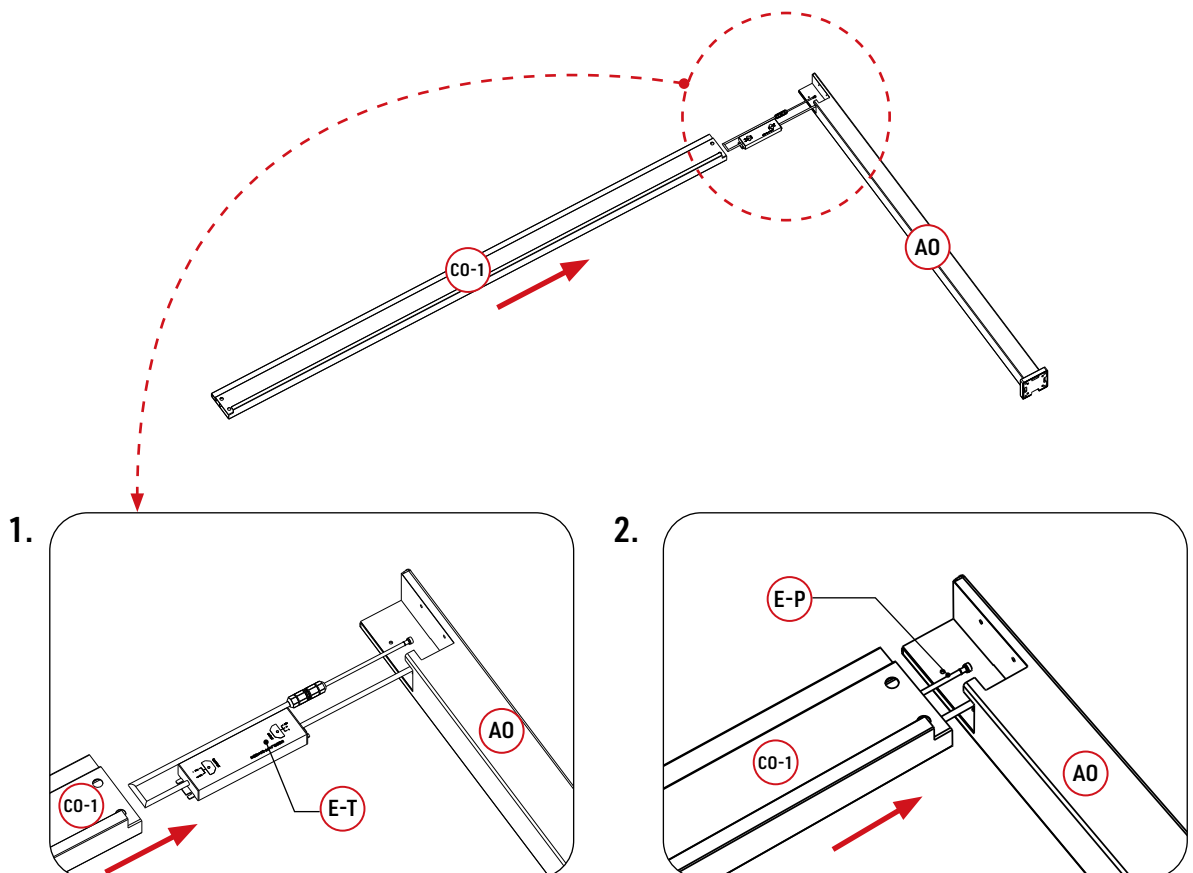

Verbinden Sie den Balken (CO-1) mit dem Pfosten (AO) gemäß dem untenstehenden Diagramm.  
Bitte denken Sie daran, das Stromkabel (E-P) außerhalb des Balkens zu halten.

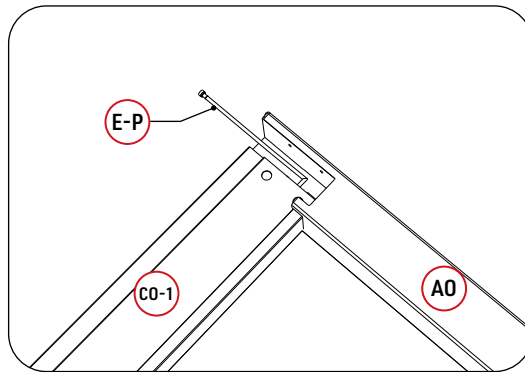

Verwenden Sie den Pistolendrill, um Schrauben am Pfosten zu befestigen, und ziehen Sie dann die Schrauben mit dem Schraubenschlüssel fest.

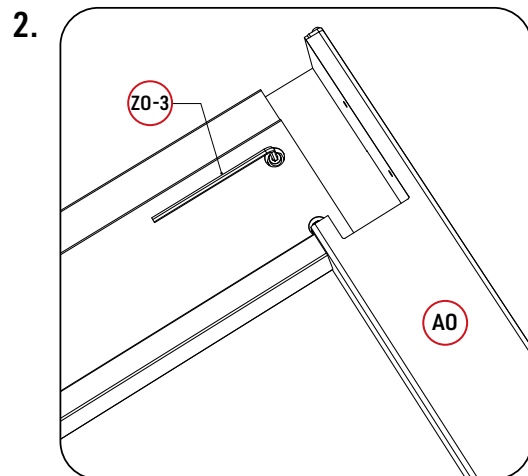
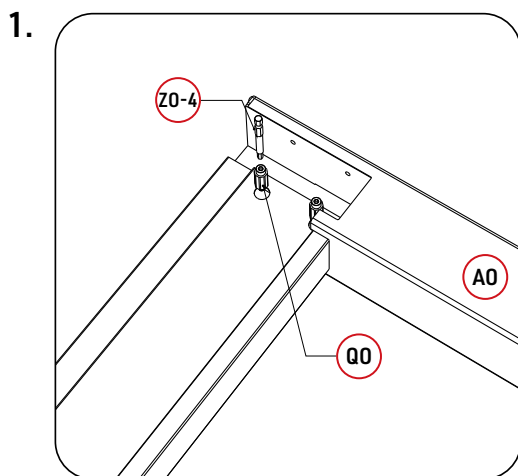
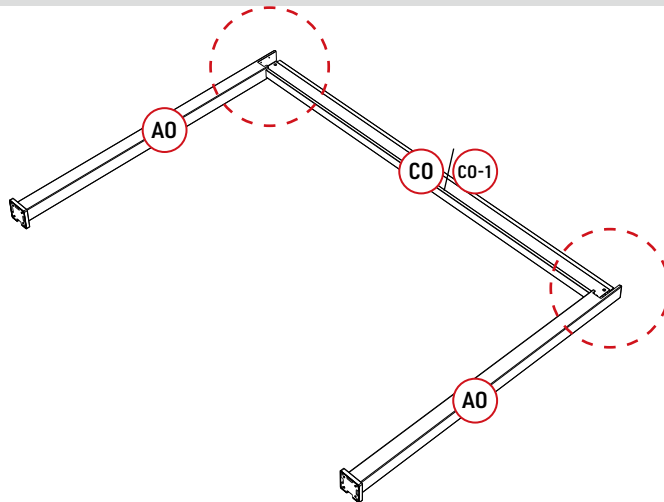



## Schritt 1: Rahmen & Motor 1-3

### Teile

B1		1
B0-1		1

Q0		8
----	---	---

### Werkzeuge

Z0-3		1
Z0-4		1

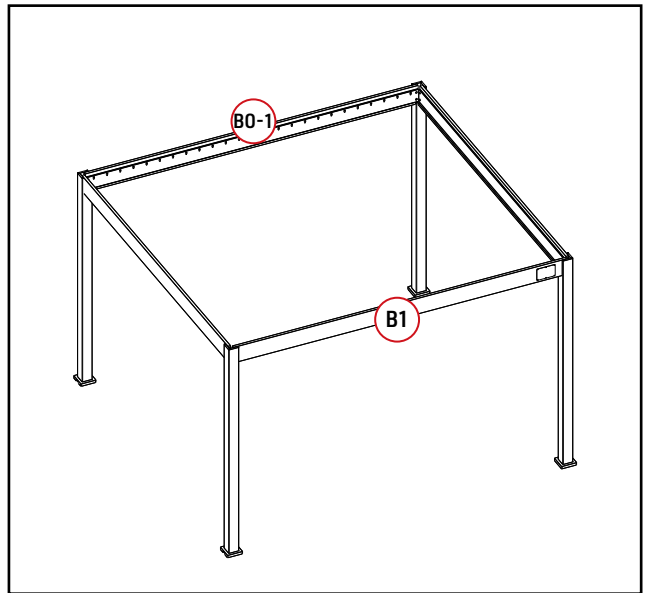

Nehmen Sie die Abdeckung vom Balken mit dem Motor ab, ziehen Sie dann das Kabel des Motors heraus und verbinden Sie es mit dem Controller.

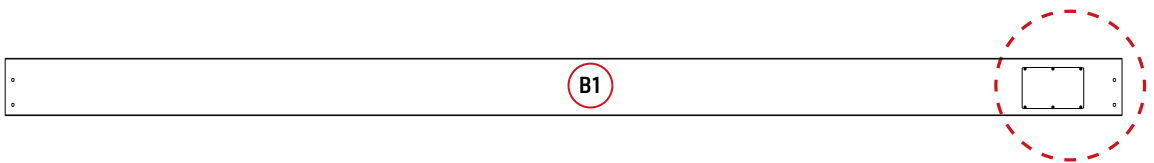

1.

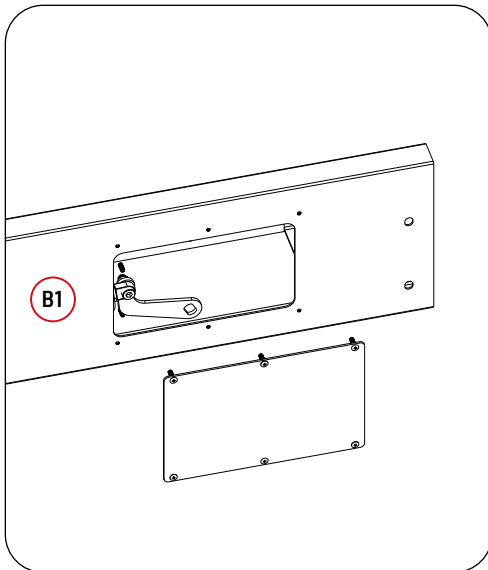

2.

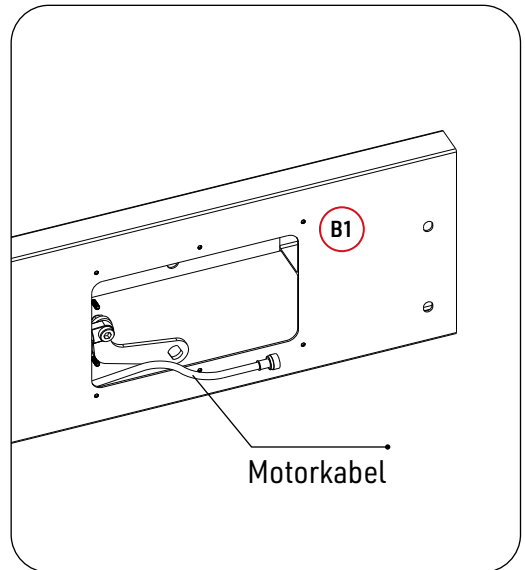



Verbinden Sie die Balken mit den Pfosten.

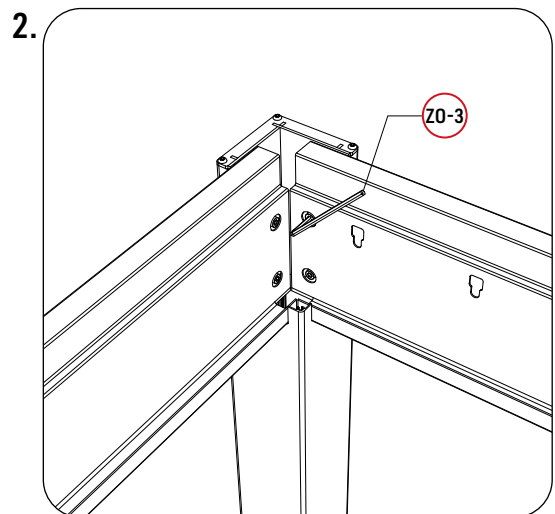
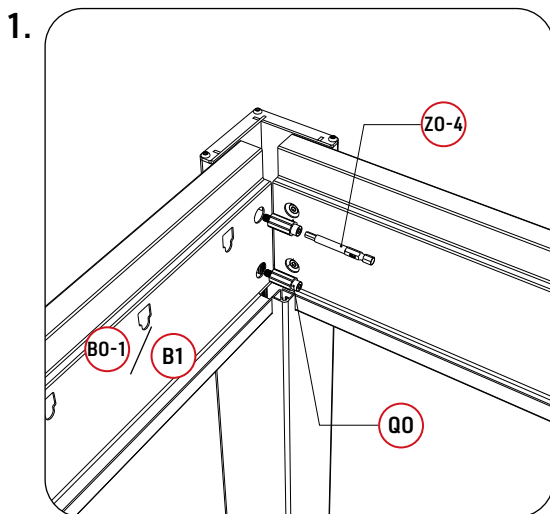
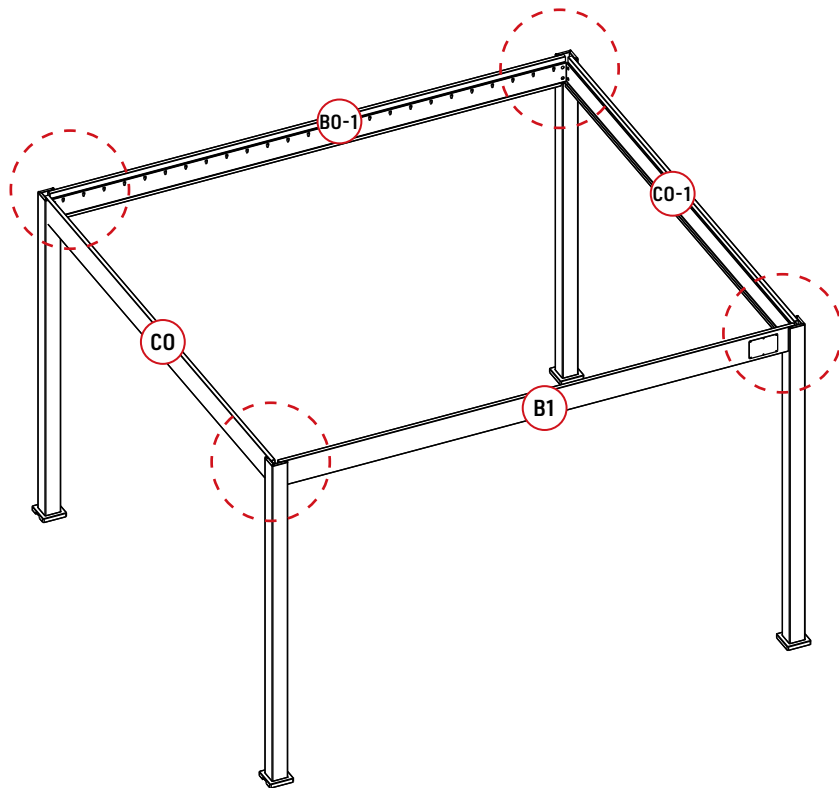

## Schritt 2: Lamellen

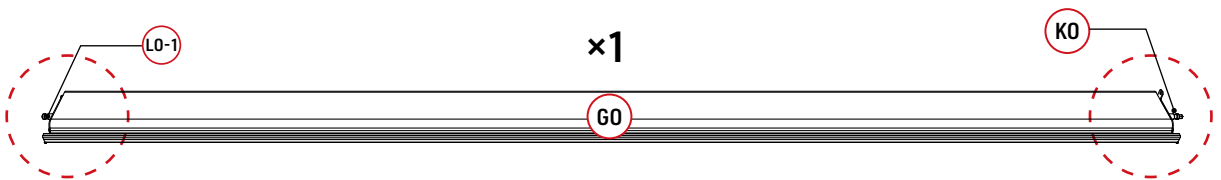
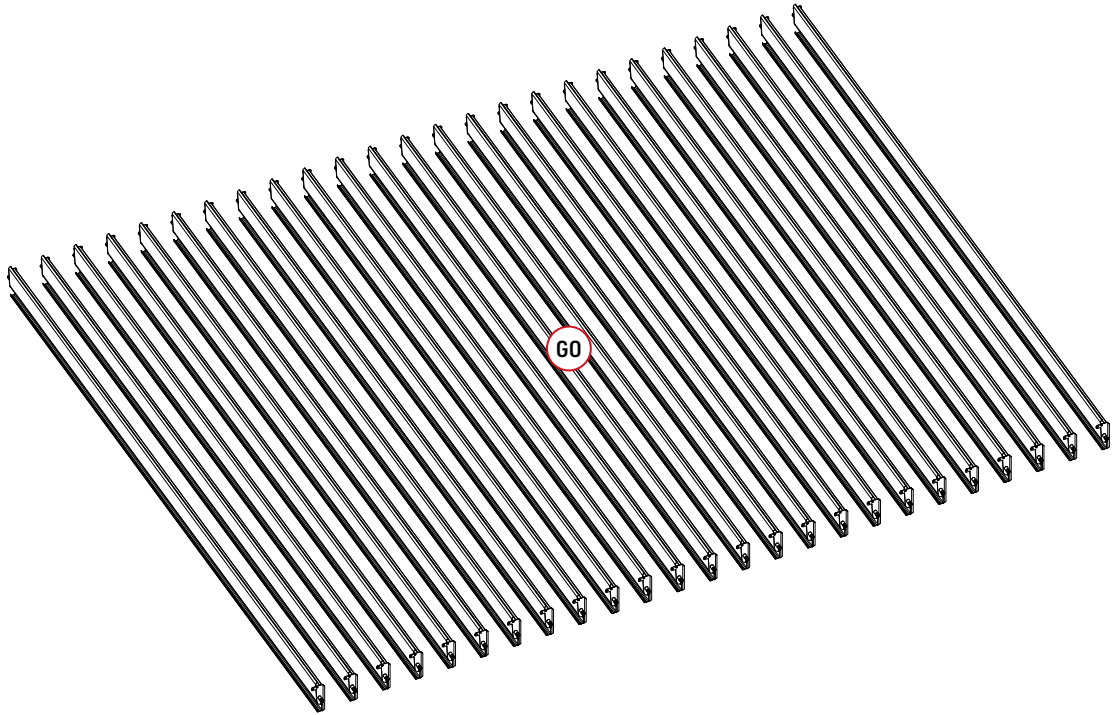

×1

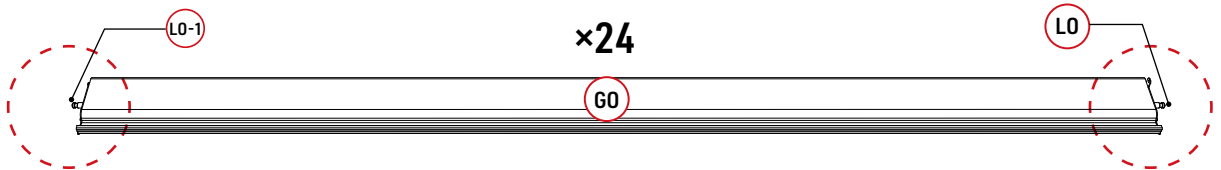

×24



## Schritt 2: Lamellen

2-1

### Teile

LO		24	MO-1		49	VO		49
LO-1		25	XO		49			
MO		49	UO		49			

### Werkzeuge

ZO-3		1
ZO-4		1

**Hinweis:** Um ein Brechen der Kunststoffteile (MO) zu vermeiden, reduzieren Sie bitte die Drehkraft des Akkuschaubers beim Gebrauch.

### Lamellenabdichtungsplatte

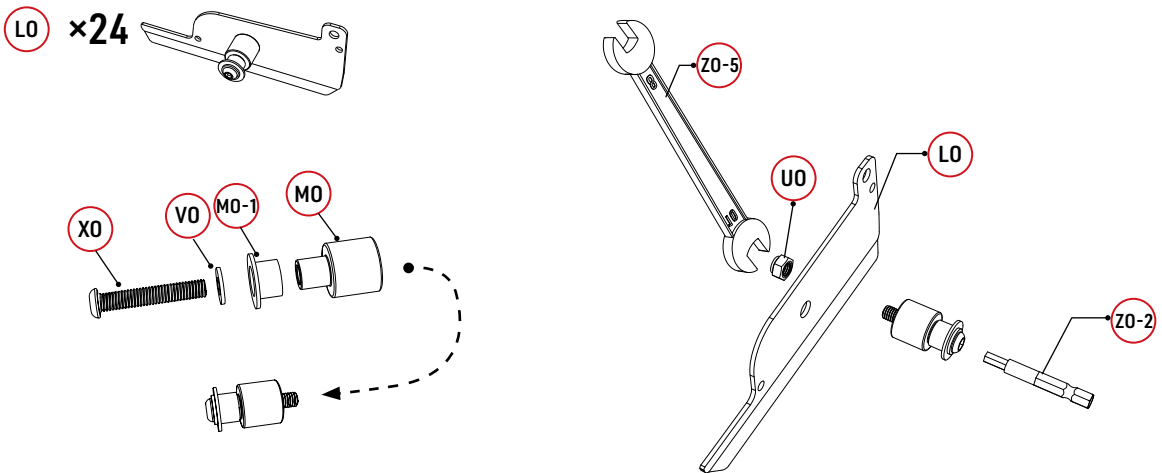



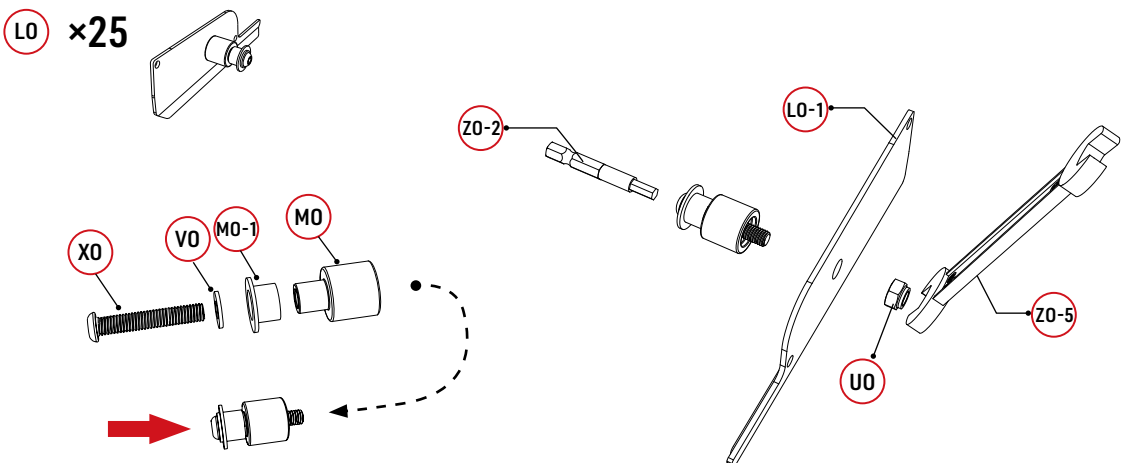

### Lamellenabdichtungsplatte





## Schritt 2: Lamellen

2-2

### Teile

GO		25
KO		1
LO		24
LO-1		25
WO		100

### Werkzeuge

ZO-1		1
ZO-2		1
ZO-6		1

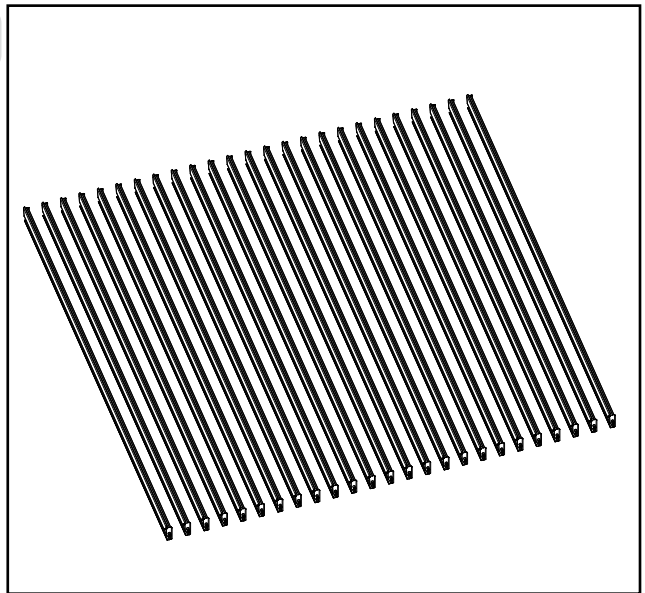

Verbinden Sie die Endkappen mit der ersten Lamelle (KO).

### Diagramm zur Fertigstellung

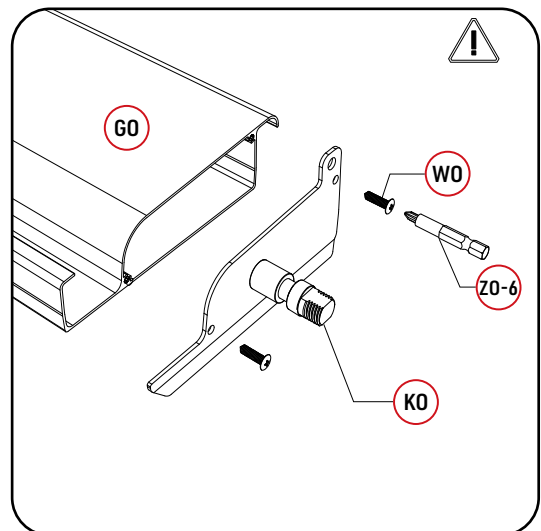
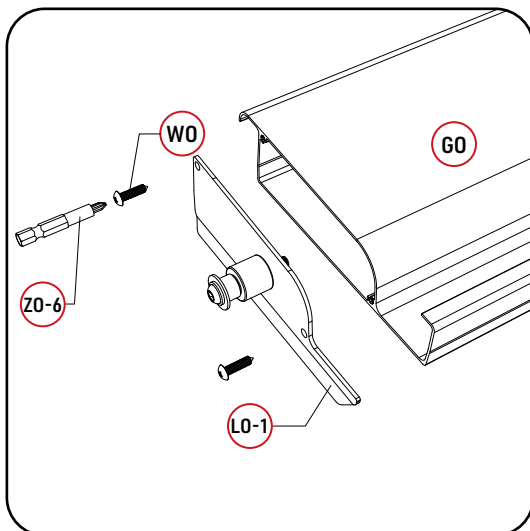
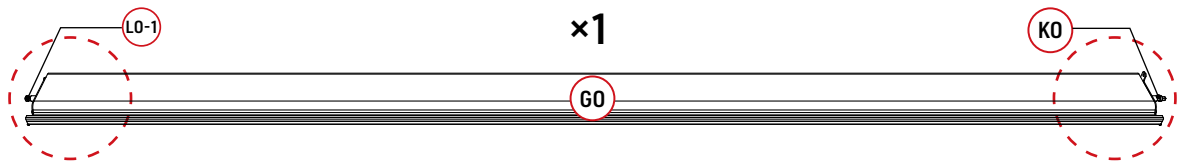

Verbinden Sie die Endkappen mit den restlichen Lamellen (LO).

Diagramm zur Fertigstellung

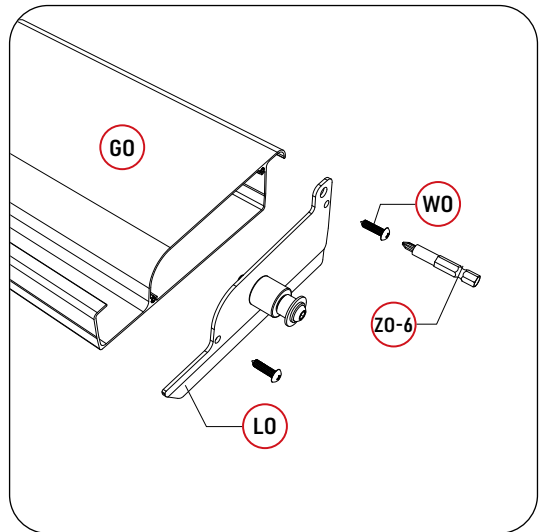
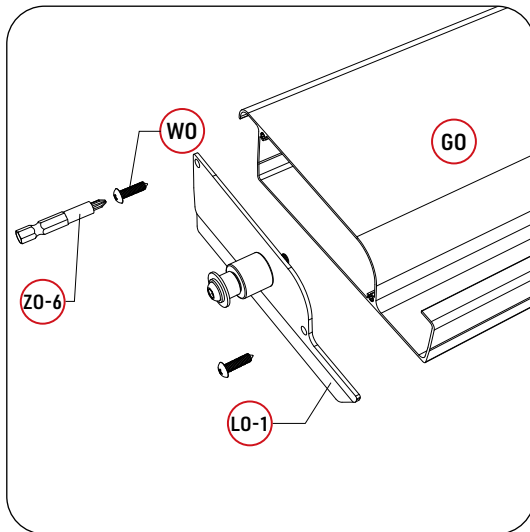
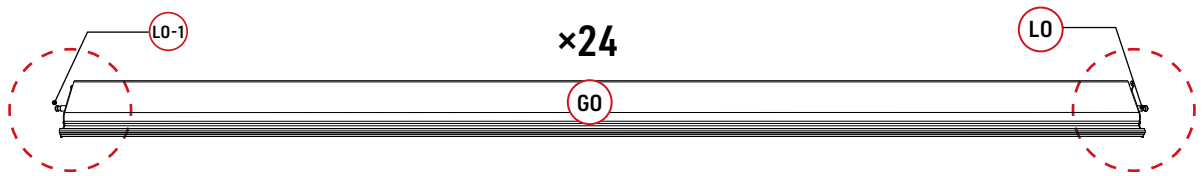

### Schritt 3: Verbindungen

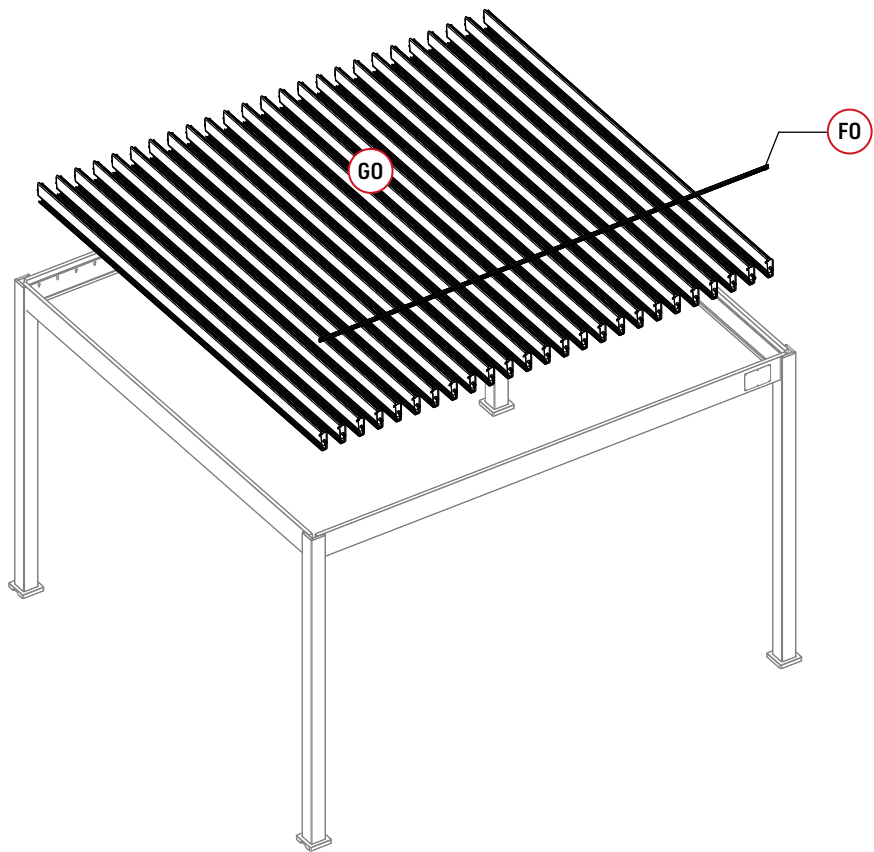

Befestigen Sie Gummistöpsel an beiden Enden der Lamellen.

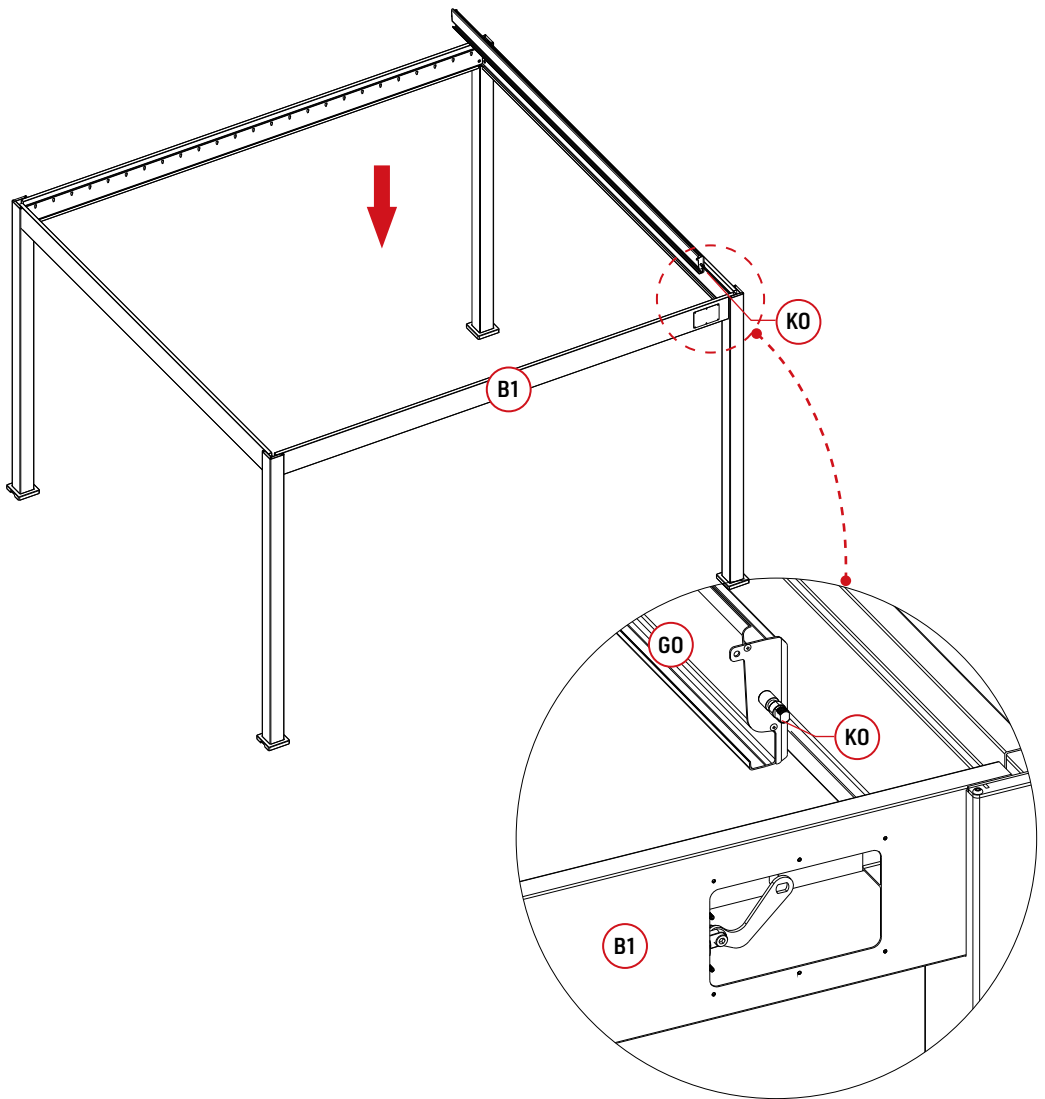

1

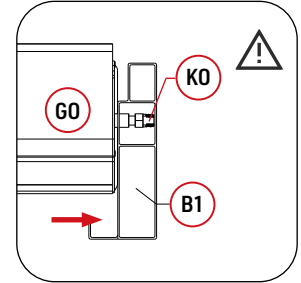
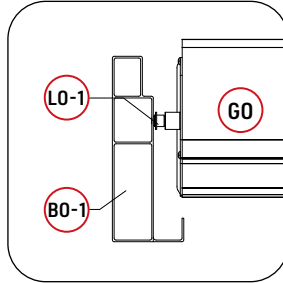
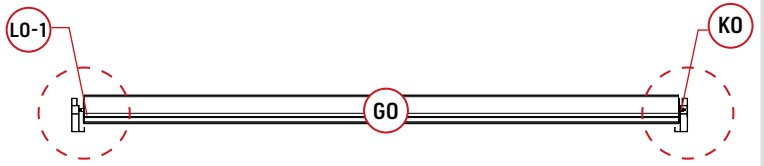
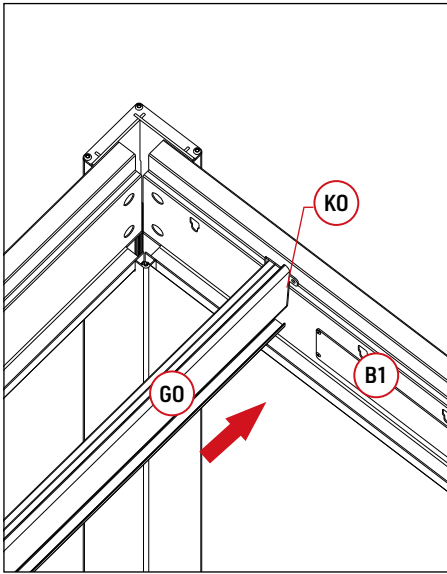

2

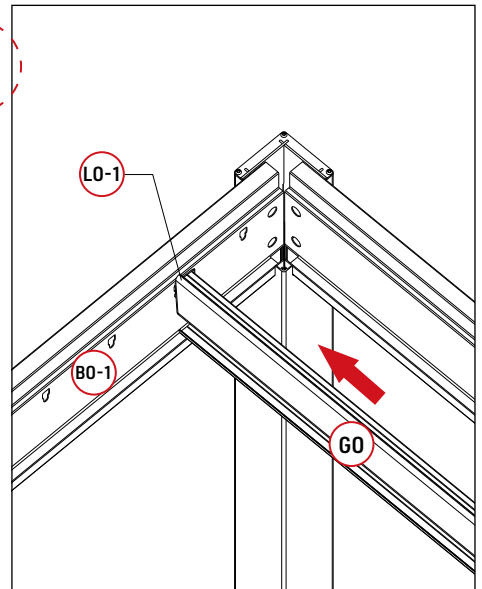
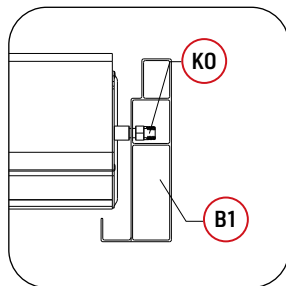
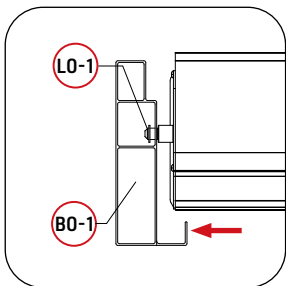
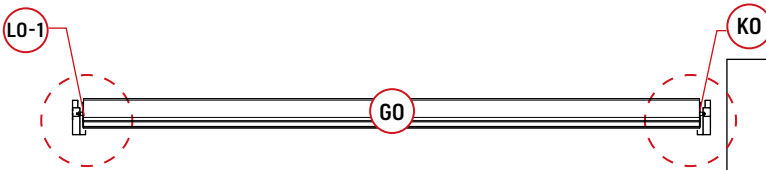



## Schritt 3: Verbindungen

3-2

Teile

U0-3	 M14	1
------	---	---

Machen Sie die Lamellen flach und verbinden Sie dann den Motorkipphebel mit der Spindel.

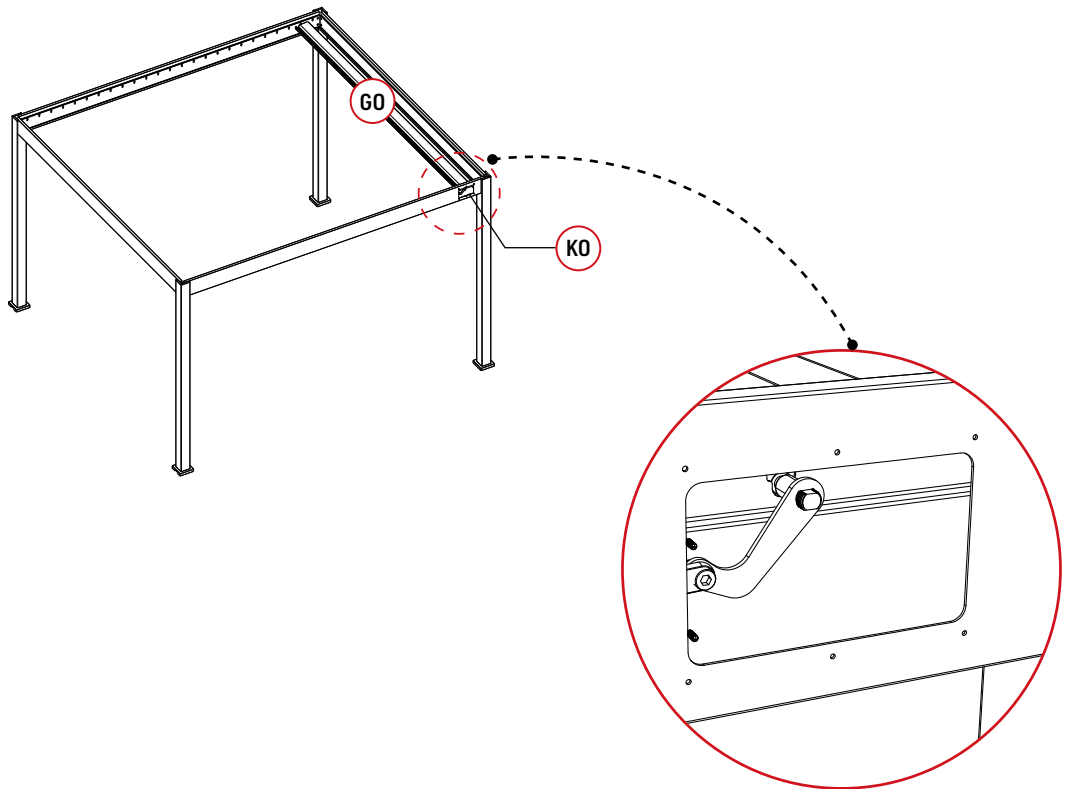

1.

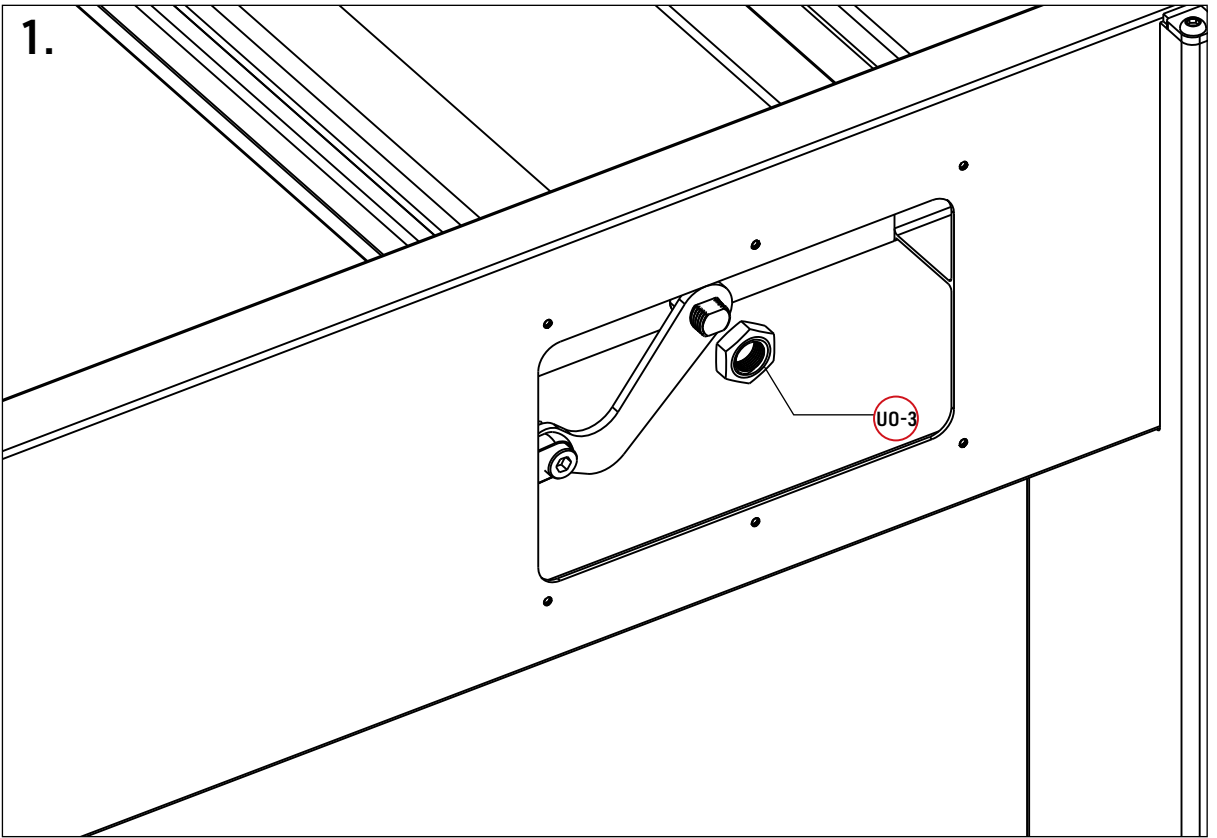

2.

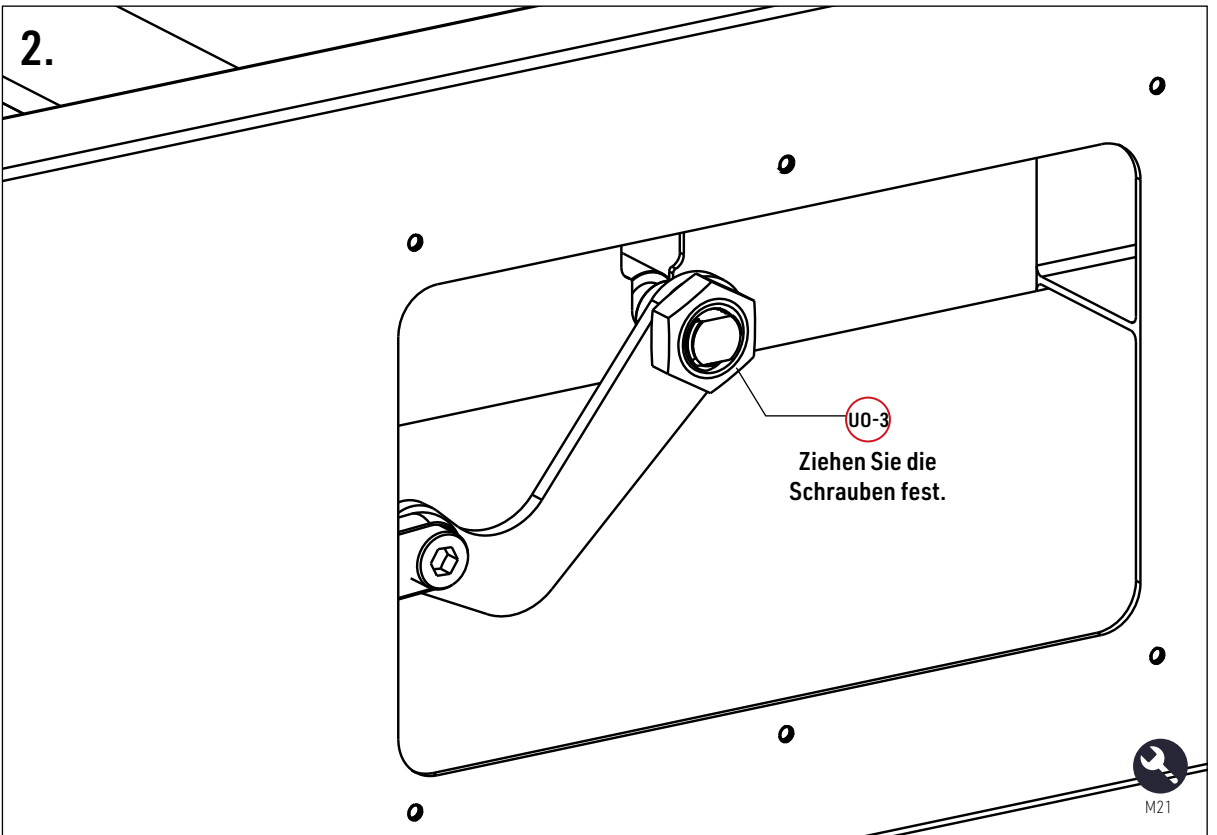

## Schritt 3: Verbindungen

3-3

1. Ziehen Sie das Stromkabel (E-P) gemäß dem untenstehenden Diagramm heraus und verbinden Sie es dann mit der Leitung 1# des Controllers (E-C).
2. Verbinden Sie die Leitung 3# des E-C mit dem Kabel des Motors.

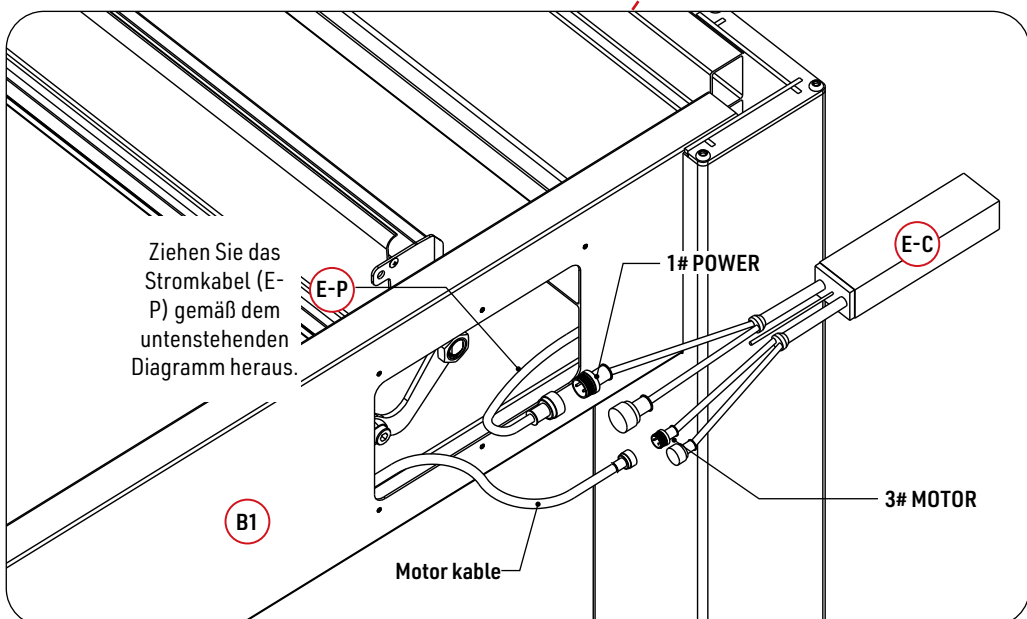
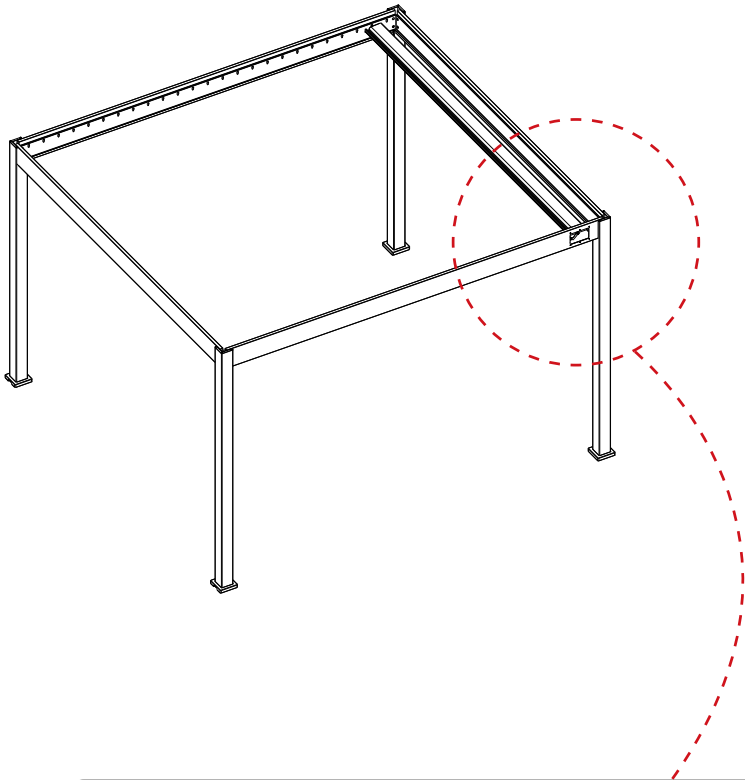

## Schritt 3: Verbindungen

3-4

E-R		1
-----	---	---

Installieren Sie die Batterie (separat erhältlich) in die Fernbedienung (E-R). Tipp: Das von uns vorgeschlagene Batteriemodell ist CR2032.

### Motorverbindung

1. Drücken Sie die UP-Taste auf der Fernbedienung und halten Sie diese Taste 3–5 Sekunden lang gedrückt, bis die Anzeige durchgehend leuchtet.
2.  Stecken Sie den Stromstecker ein und drücken Sie dabei die UP-Taste. Wenn eine leichte Vibration am Hauptlamellen erscheint, bedeutet dies, dass die Fernbedienung und der Motor gekoppelt sind.

#### Schritt 1.

Drücken und halten Sie für 3 Sekunden.

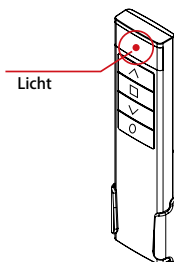
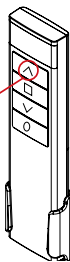

#### Schritt 2.



Stecken Sie den Stromstecker ein.

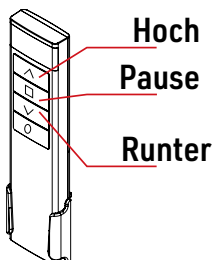

1. Überprüfen Sie, ob der Motor einwandfrei funktioniert. Wenn nicht, überprüfen Sie bitte zuerst, ob die Verkabelung in den vorherigen Schritten korrekt ist.
2. Wenn der Motor gut funktioniert, drehen Sie bitte die Hauptlamelle um 90 Grad und installieren Sie dann die restlichen Lamellen.

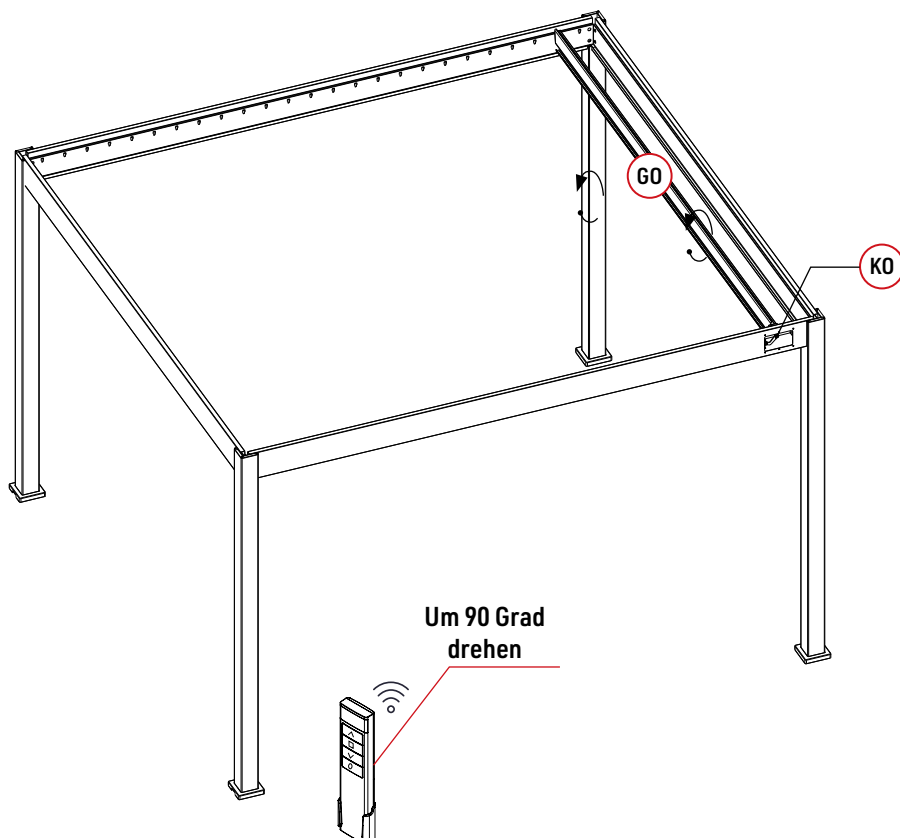

## Schritt 3: Verbindungen

LED

Setzen Sie den LED-Streifen in die Regenrinne ein.

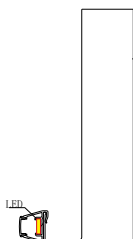

Legen Sie die Ausgangsleitung des LED-Controllers (L-C1) in die Hohlung des Pfostens.

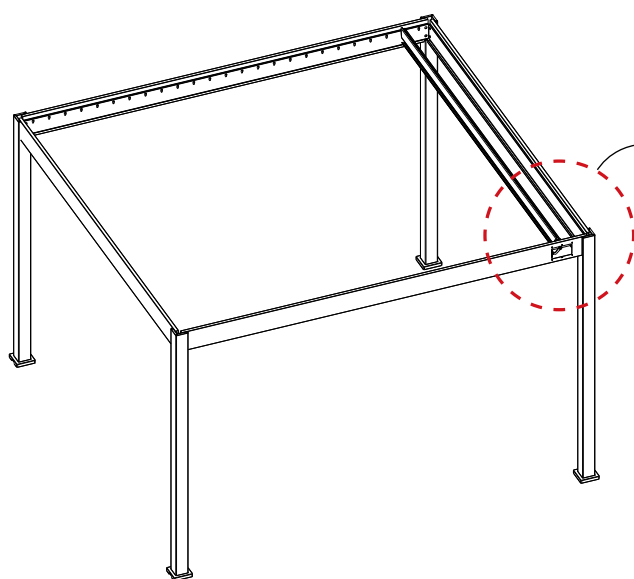
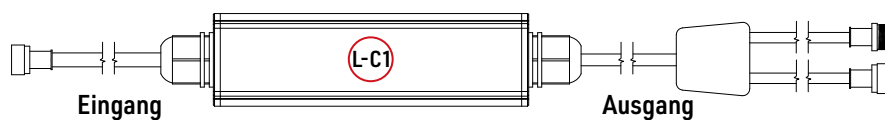

1.

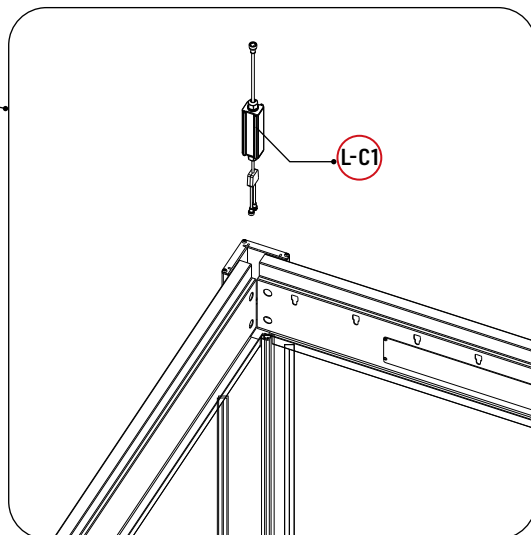

Bitte beachten Sie, dass das Eingangsende des LED-Controllers nach oben gerichtet sein sollte, während das Ausgangsende nach unten gerichtet sein sollte. Für die beiden Kabel am Ausgangsende ziehen Sie diese bitte mithilfe der mitgelieferten Bürste aus der Entwässerungsnut heraus.

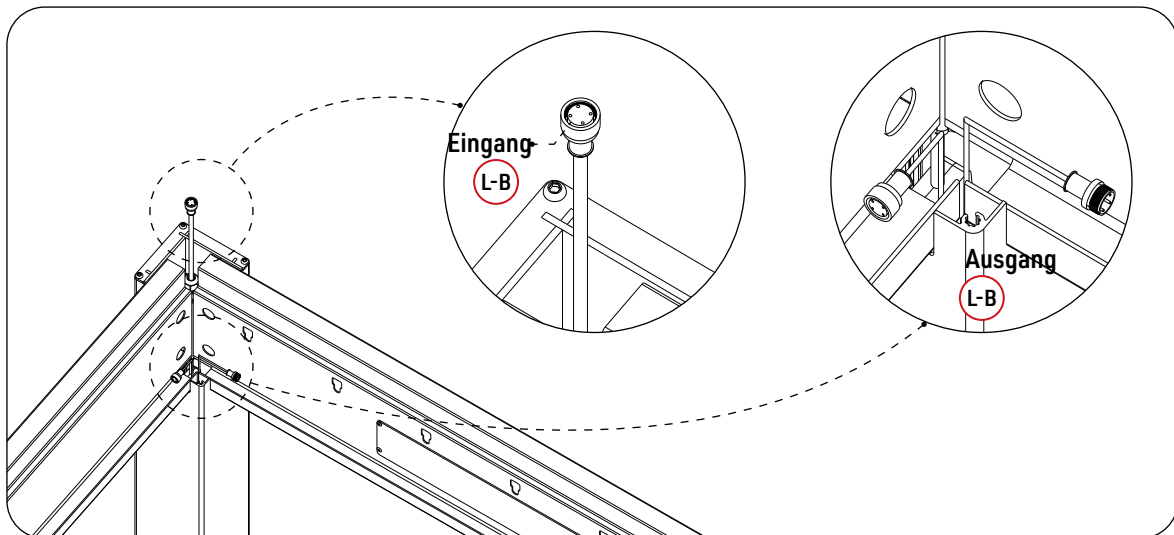

Verbinden Sie die Eingangsleitung des LED-Controllers (L-C1) mit der 2# LED des Controllers (E-C).

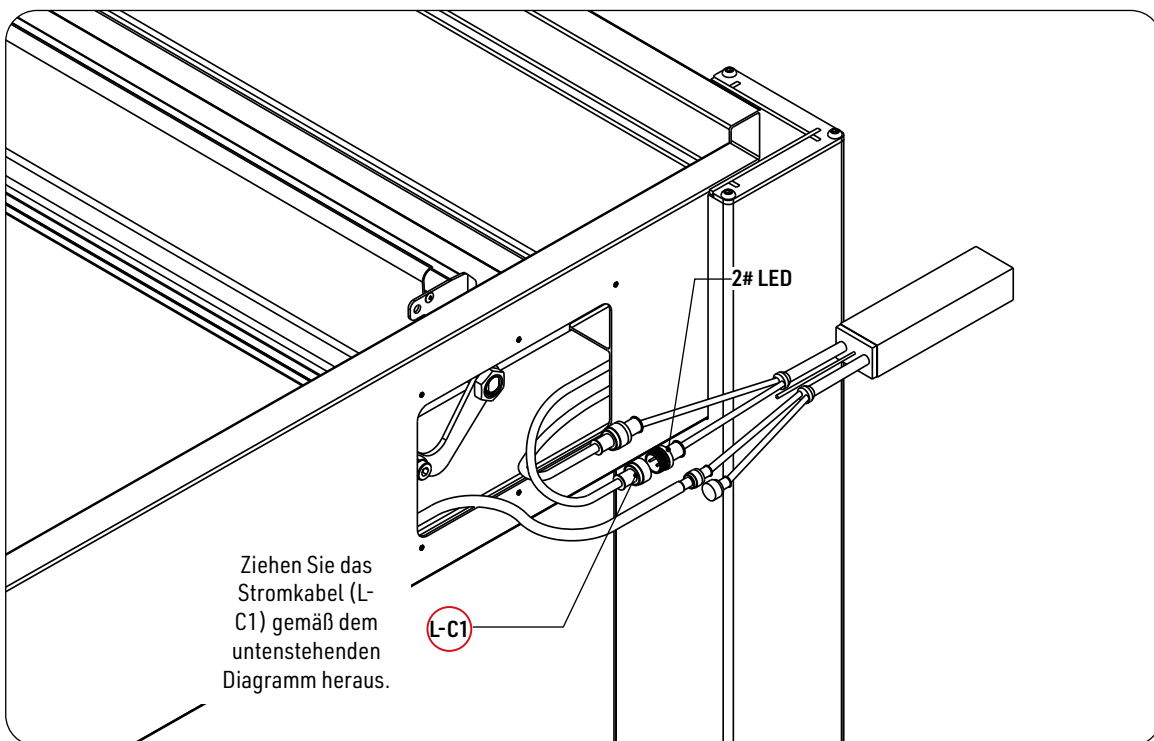

## Schritt 3: Verbindungen

LED

Installieren Sie alle LED-Streifen in Serie und verbinden Sie dann die beiden Enden des LED-Streifens mit den beiden Ausgangsleitungen des LED-Controllers (L-C1).

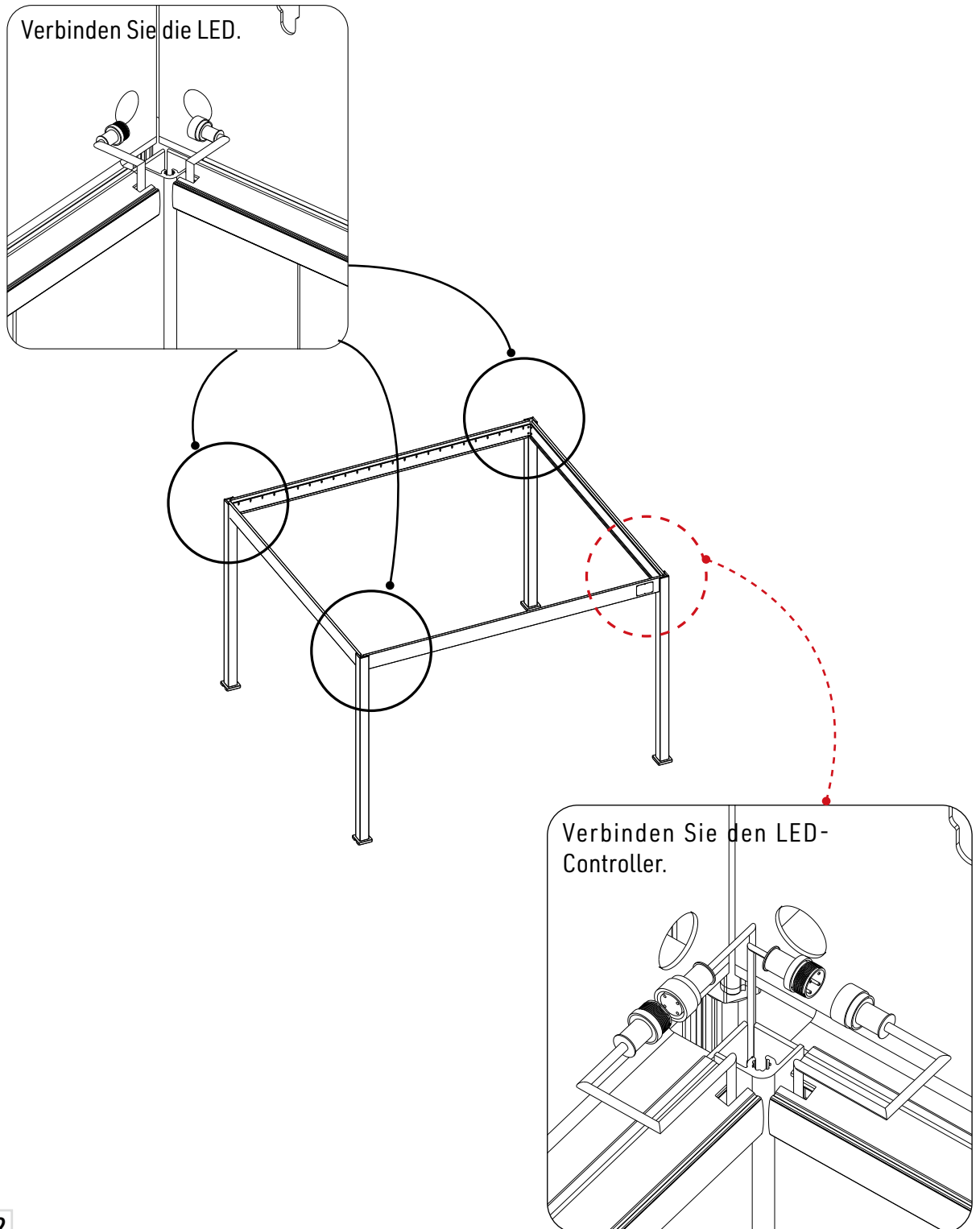



Die Fernbedienung verfügt über die folgenden Funktionen:

Steuerung des Ein- und Ausschaltens der LED

Steuerung der Drehung der Lamellen

Wenn Sie die LED-Farbe steuern möchten, laden Sie bitte die untenstehende APP herunter.

Die LED-Farbstreuung ist nur verfügbar, wenn Sie Zugriff auf WLAN haben.



## Tuya Smart

### Tuya-App Netzwerkverbindung

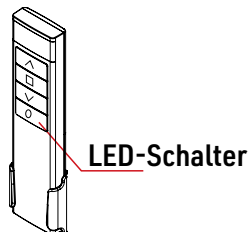

Wenn die LED beim Einschalten nicht verbunden werden kann, setzen Sie bitte den Controller der LED zurück.

Schalten Sie das Gerät fünfmal hintereinander ein und aus, löschen Sie auch die vorherige Netzwerkverbindung, geben Sie den Smart-Konfigurationsmodus ein, und die Ausgangs-LED wird 10 Mal blinken.

## Schritt 3: Verbindungen

3-5

Nachdem alle Kabel verbunden und der LED-Streifen sowie die Lamellenrotation eingestellt wurden, legen Sie bitte den Controller (E-C) gemäß dem untenstehenden Diagramm in die Höhlung des Balkens (B1).

Um ein Einklemmen der Kabel zu vermeiden, achten Sie bitte darauf, dass der Controller (E-C) und alle Kabel außerhalb des Bewegungsbereichs des Schwenkarms des Motors gehalten werden.

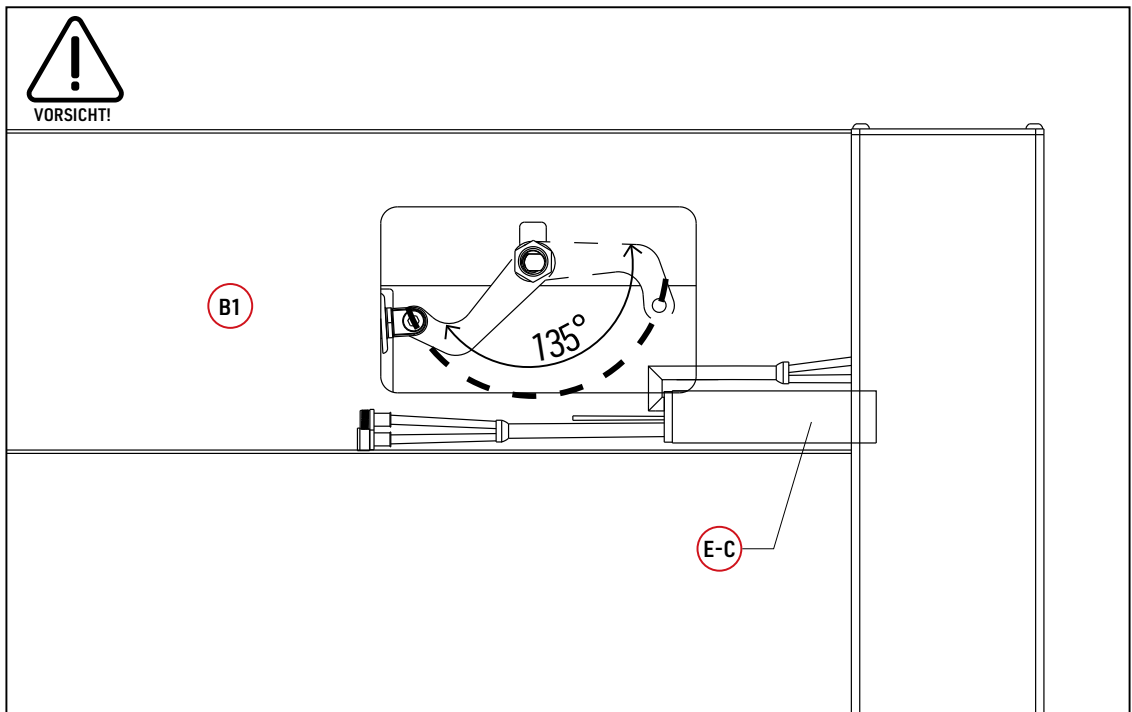

## Schritt 3: Verbindungen

3-6

Teile

SO		50
----	---	----

Installieren Sie die restlichen Lamellen auf dem Balken und stellen Sie sicher, dass die Lamellen flach sind.

Decken Sie den Schraubenkopf mit Kunststoffkappen ab.

1

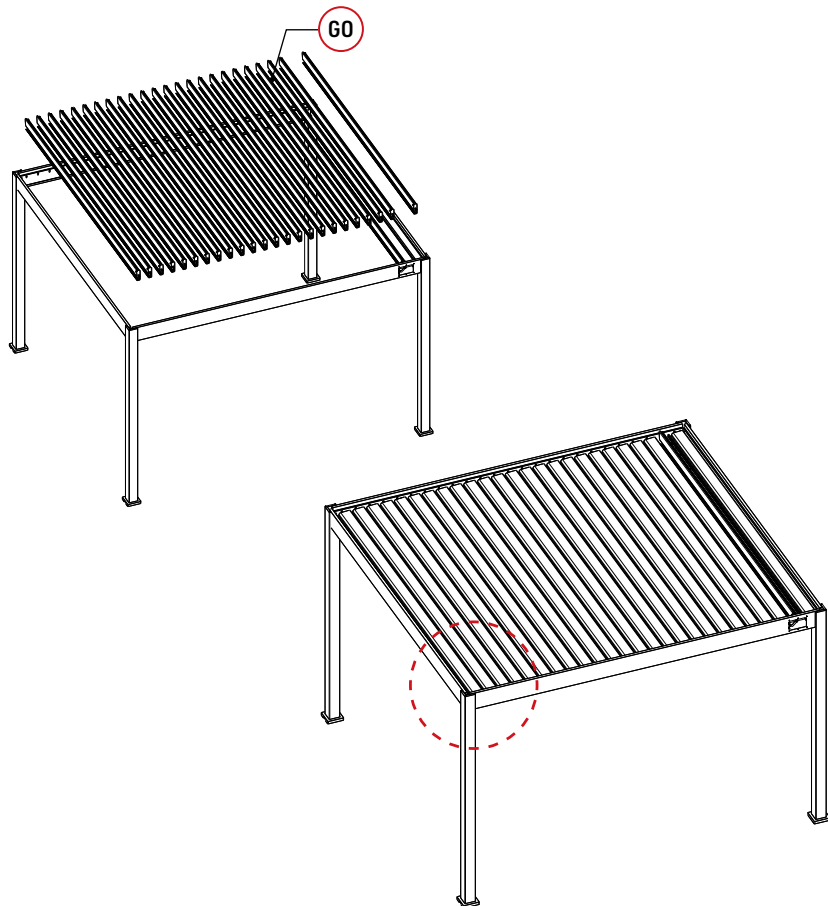

2

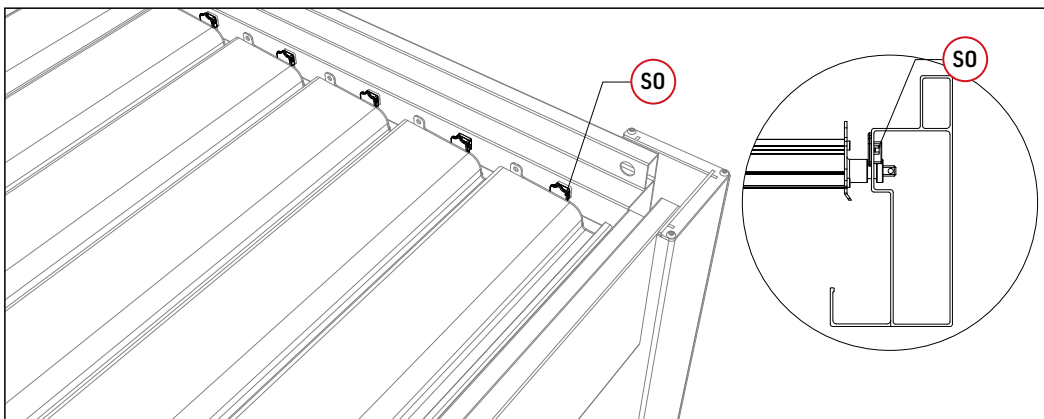





# Schritt 3: Verbindungen

3-7

## Teile

FO		1
----	---	---

X0-2		25
VO		75
U0		25
U0-1		25

Z0-1		1
Z0-2		1
Z0-5		1

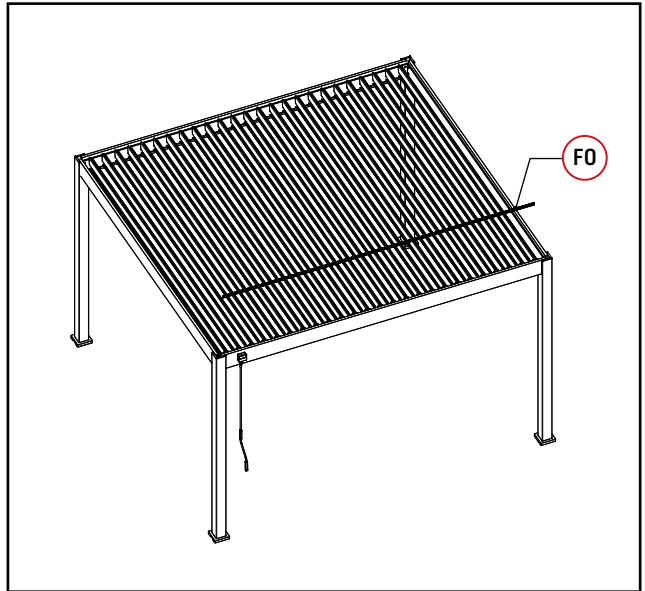

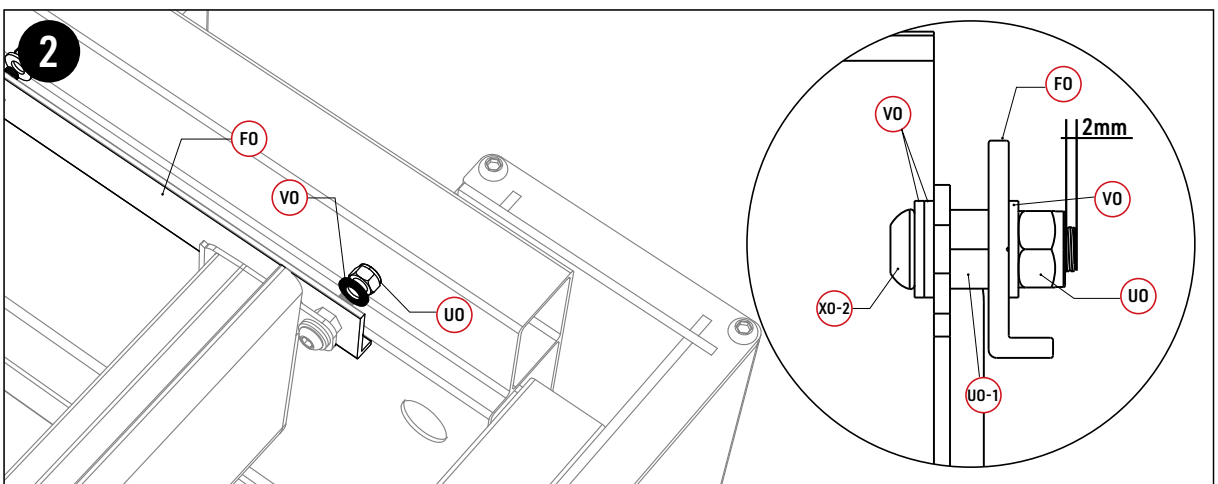
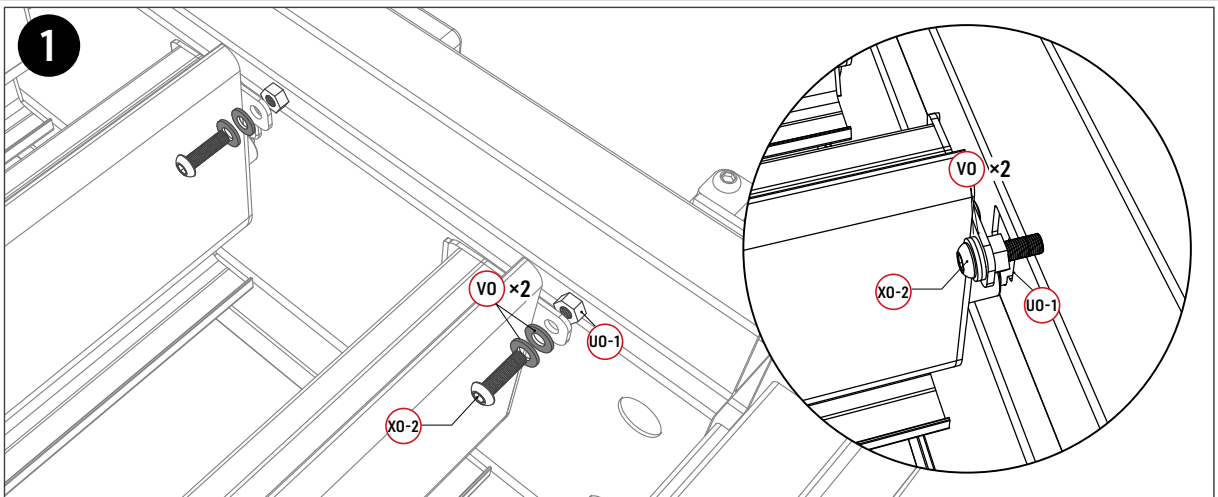

Schließen Sie die Verbindung der Lamellen mit dem FO-Teil ab



## Schritt 3: Verbindungen

3-8

Teile

RO		16
TO	 10x80	16

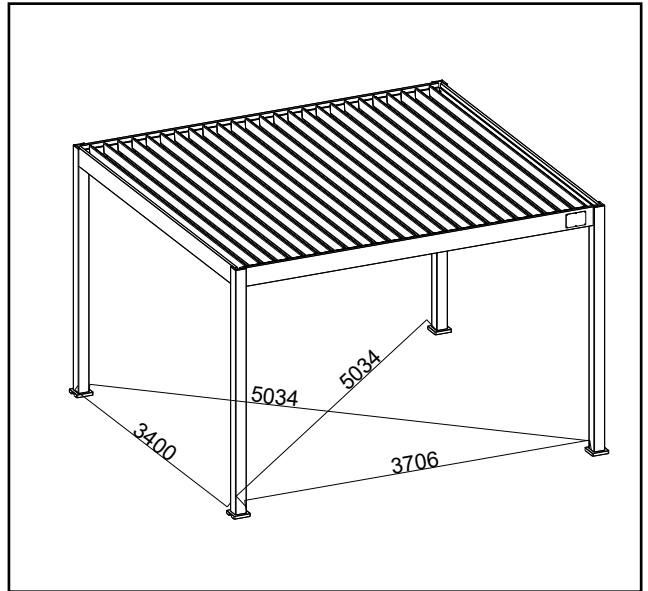

Schließen Sie die Abdeckung, um die Befestigung der Pergola zu beenden.

1

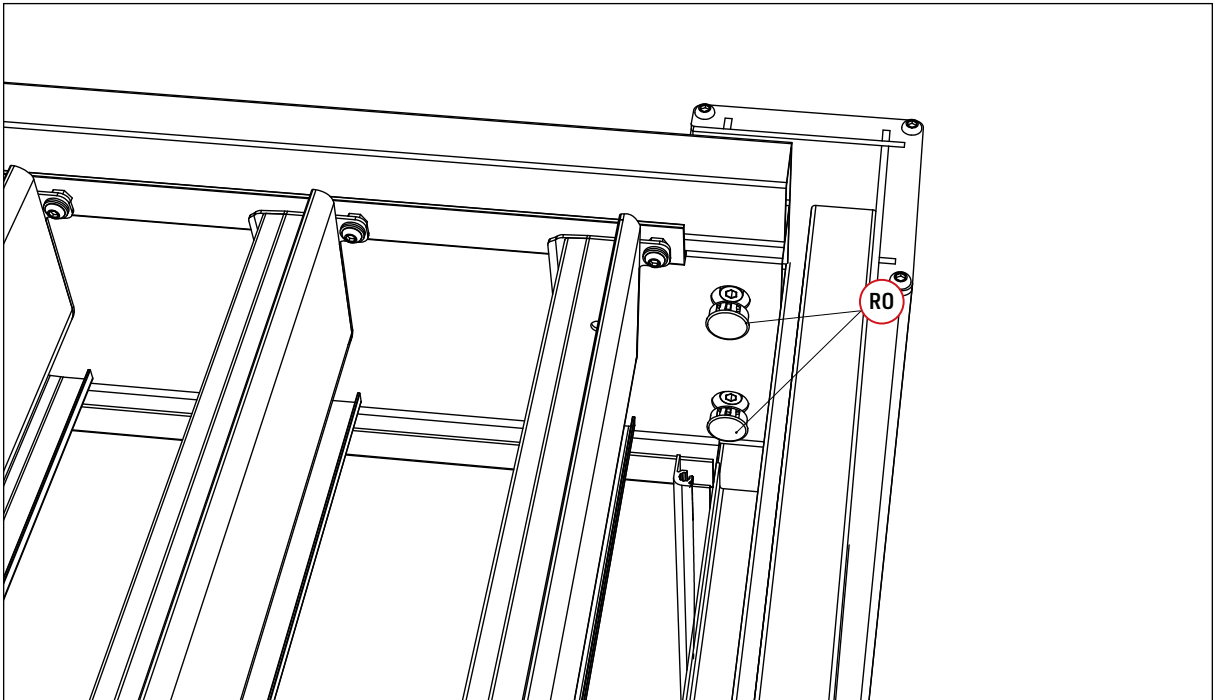

2

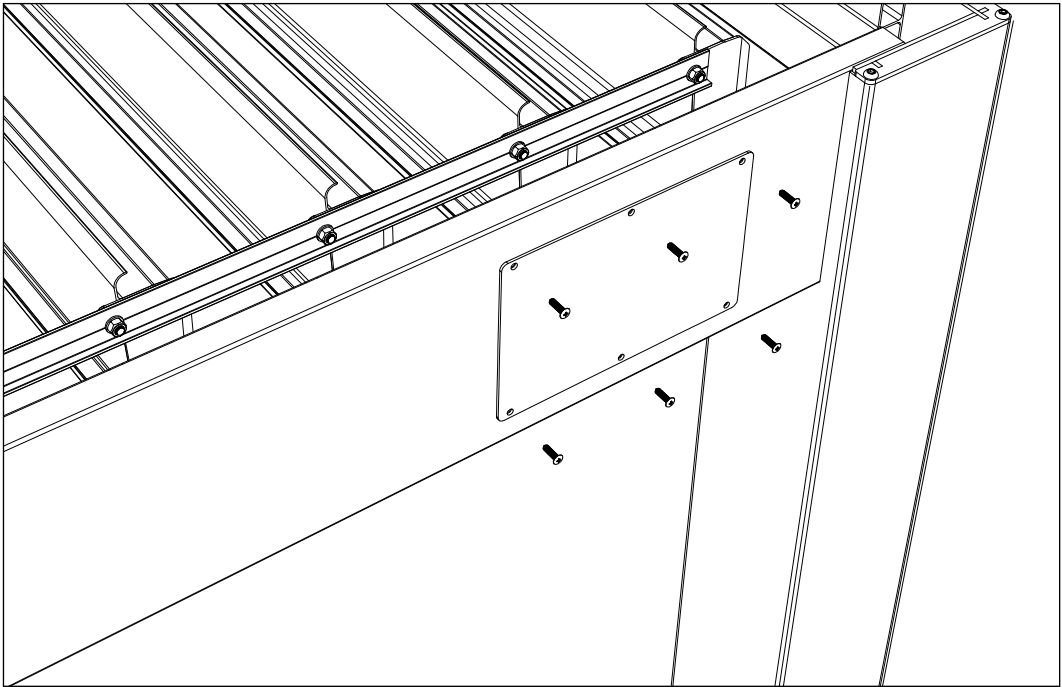

3



Prüfen Sie, ob alle Fundamente richtig dimensioniert sind, und befestigen Sie dann alle Bodenplatten.

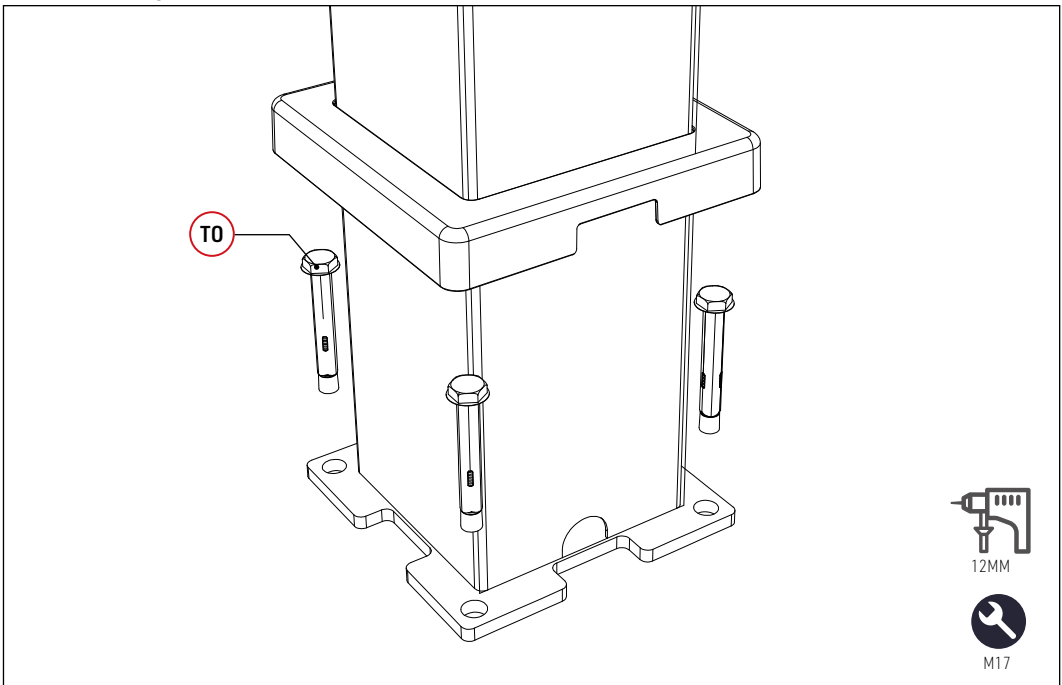

# 3,6x4 meter Pergola Electric, Aluminum, LED

Assembly Instructions - EN

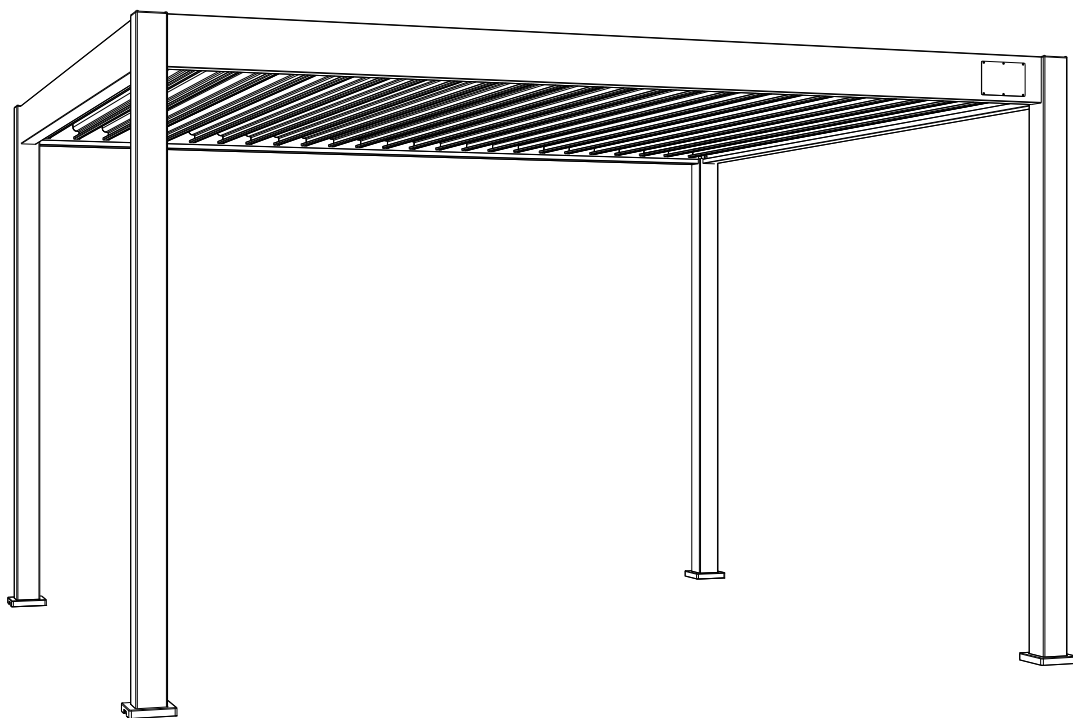

# E-Deluxe Aluminum Pergola 3,6×4 meter

These instructions have to be saved during the whole product life cycle. We advise you to read these very carefully before proceeding to the assembly. The user will be reliable for any damages or injuries caused due to incorrect or improper installation.

## NECESSARY TOOLS AND SAFETY GEAR (NOT SUPPLIED)

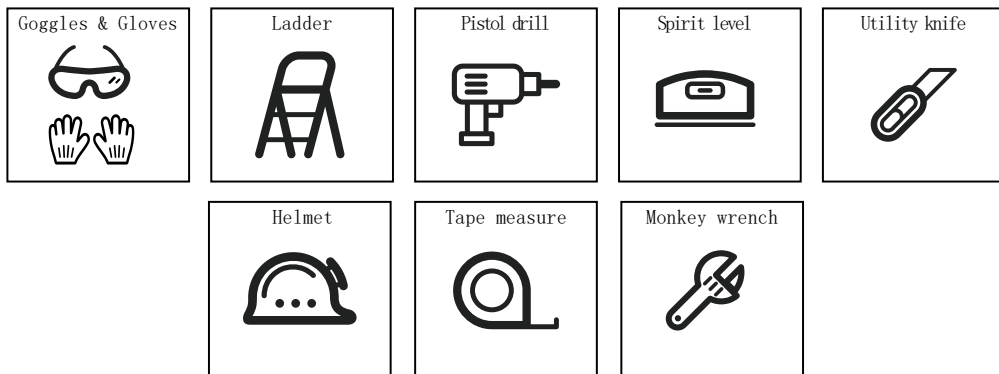

## 2D FOOTING MEASUREMENT (dimensions in mm)

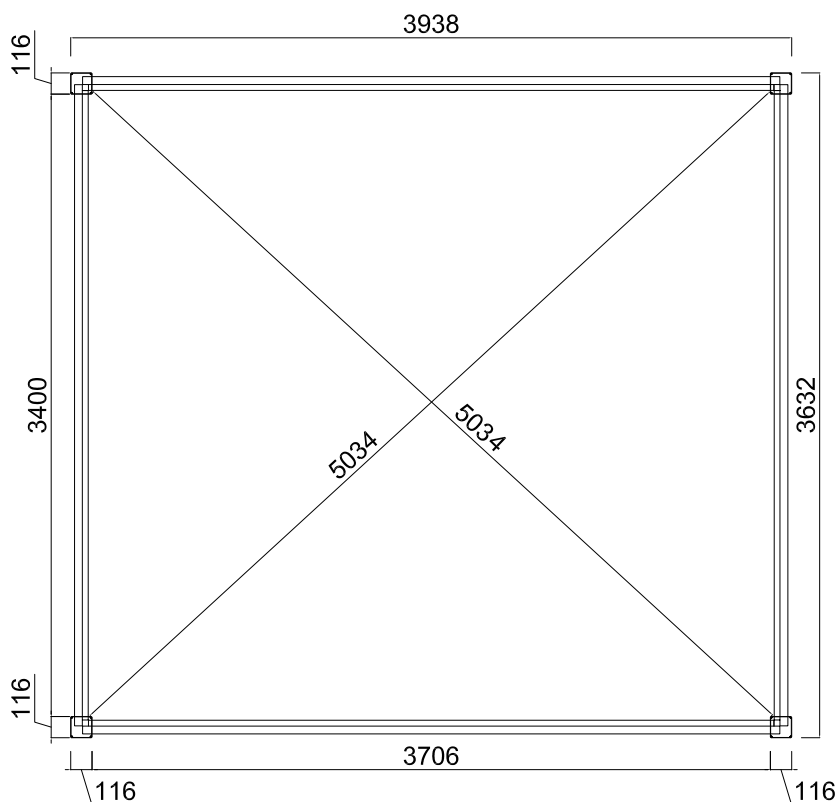



## 3D FOOTING MEASUREMENT (dimensions in mm)

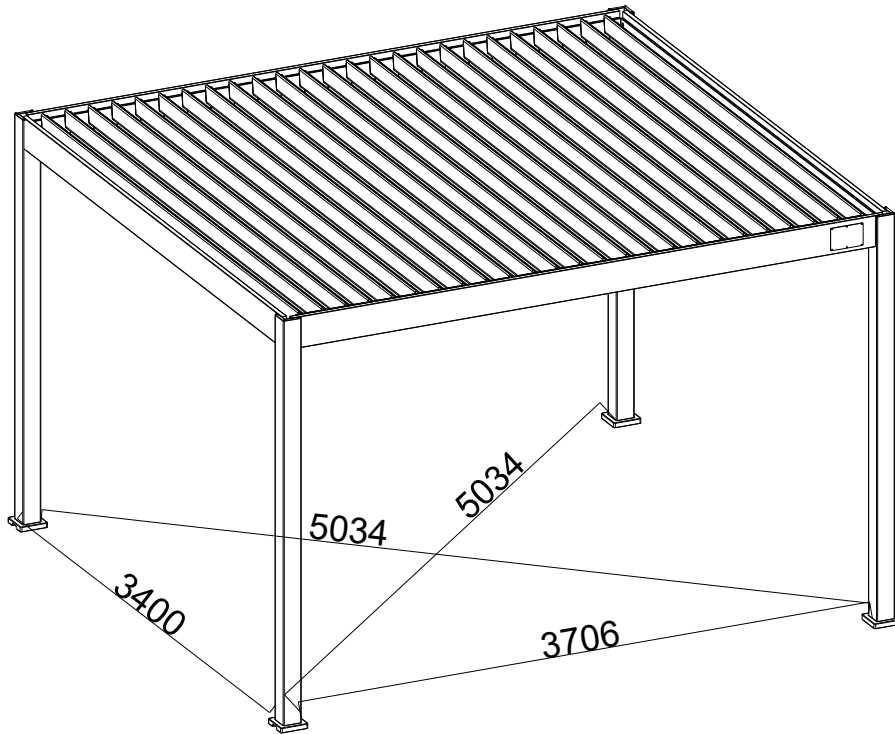

## PRECAUTION OF USE

This product should not be used in extreme weather: storms, violent winds, hail, and snow. We guarantee the resistance of the pergola for winds up to 88km/h and a maximum snow weight of 50kg/m<sup>2</sup>.

As in the case of strong winds or snow, we highly recommend leaving the louvers open. To maintain good working conditions of your louvres, please clear any snow on them.

Our pergola can withstand heavy rain, but we cannot guarantee it will be 100% waterproof due to some extreme weather conditions.

Exceptional climatic events may compromise the perfect sealing of the product.

To avoid any damages and injuries, we do not recommend climbing on the roof or the structure of the pergola.

## TIPS AND SAFETY INSTRUCTIONS

Depending on the location and surface area, construction may be subject to building permits. Make sure you have checked with your local authorities to obtain the needed information before the assembly.

Product assembly :

- At least 2/3 people required
- Remove protective film (around 1 hour needed)
- Do not keep children near the assembly area
- Beware of the risk of pinching
- Do not tighten the screws before assembling the whole product
- All assembly steps must be carefully followed
- Check the level of the structure on all sides
- Do not anchor the pergola before assembling the whole product

No changes can be made to the product. Products tampered with by the user are not covered by the warranty, thus being declared as void.

The location should be chosen carefully. It is recommended to avoid mounting your pergola on a rainy day, facing the prevailing winds, and under an overhanging tree.

The pergola must be mounted on a flat-level foundation. It is recommended to install it on a concrete slab or 25x25 cm concrete pads at each post. Please, anchor the pergola properly to the ground using expansion screw.

If you would like to mount your pergola near your house or a building, please check the presence of gutters for water drainage.

Should these instructions not be followed or only partially, the warranty will be voided by the seller.

## MAINTENANCE

Regular maintenance is necessary to ensure its longevity and aesthetic appearance.

We recommend to :

- Clean your pergola once or twice a year with fresh water using a sponge or cloth.
- Do not use detergent or an abrasive material.
- Check the tightness of the screws regularly (at least once a year).
- Oil fastening regularly (at least once a year).
- Make sure that nothing hinders the water flow in the gutters (leaves, branches...).
- Remove any water that might stagnate around the legs of the pergola (lift the posts skirts).

## WARRANTY

This warranty does not cover :

- Normal wear and tear inherent from the products.
- Loss or breakage of any part during unpacking or installation.
- Lack of care, neglect, vandalism, impact with foreign body, force, contact with a abrasives material, product aesthetics, disassembly, rebuilding or relocation.
- Force majeure: hail, high winds, storms, snow, floods, lightning etc...
- Product tampered with by the user.

The warranty only takes in account the replacement of spare parts or the provided product, no refund will be issued.

All warranty claims must be made at the sales outlet (store or website) where the product has been purchased.

## PARTS LISTS (PER CARTON)

Before proceeding with the assembly of your louvered pergola, it is necessary to check that all parts listed are supplied and not damaged.







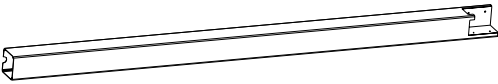

Any missing part must be reported within 10 days of delivery.



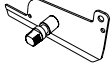
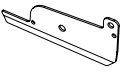
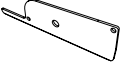



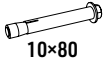

You can either go through your local outlet store or make the request directly on our website.

Do not discard the packaging without ensuring that the product is functioning properly.



# CARTON 1/5(POSTS AND LOOSE PARTS)



Reference	Parts	Quantity
A0		4

Reference	Parts	Quantity
I0		4
J0		4
K0		1
L0		24
LO-1		25
M0		49
MO-1		49
Q0		16
RO		16
SO		50



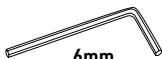

Reference	Parts	Quantity
T0	 10×80	16
U0	 lock nut	74
U0-1	 plastic nut	25
U0-3	 M14	1
V0		124
W0	 4×16 PH2	100
X0	 6×40 4mm	49
X0-1	 6×35 4mm	16
X0-2	 6×20 4mm	25

# CARTON 1/5(POSTS AND LOOSE PARTS)



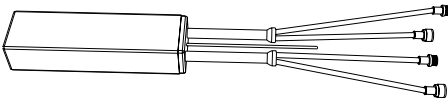

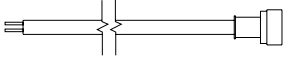
Reference	Parts	Quantity
ZO-1	 4mm	1
ZO-2	 4mm	1
ZO-3	 6mm	1

Reference	Parts	Quantity
ZO-4	 6mm	1
ZO-5	 10mm	1
ZO-6	 PH2	1

## Electrical products

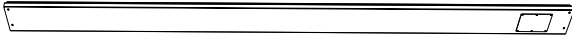
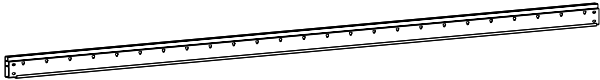
Reference	Parts	Quantity
E-C	 Controller	1
E-R	 Remote control	1
E-P	 Power cable(M15)	1
E-W2	 Waterproof joint(2)	1
E-W3	 Waterproof joint(3)	1

# CARTON 2/5(BEAMS )

Reference	Parts	Quantity
B1	 *Motor inside	1
BO-1		1
CO		1
CO-1		1
FO		1



**ATTENTION!**

**Connecting Bar(FO) & Brush Inside!**

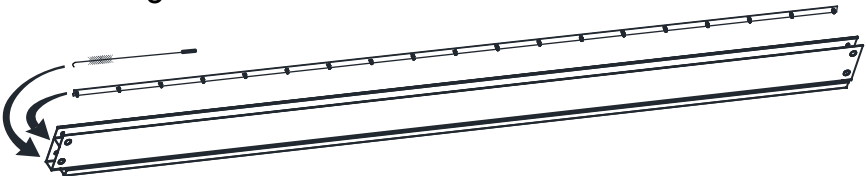



## Electrical products

E-T	 <p><b>Transformer</b></p>	1
-----	--	---

## CARTON 2/5(BEAMS )

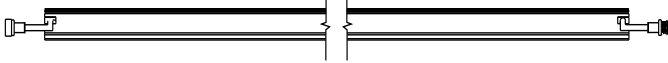
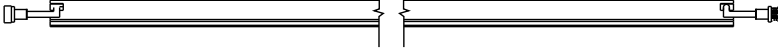
### LED products

Reference	Parts	Quantity
LED1		2
LED2		2
L-B		1

## CARTON 3/5(LOUVERS )

Reference	Parts	Quantity
GO		9

## CARTON 4/5(LOUVERS )

Reference	Parts	Quantity
GO		9

## CARTON 5/5(LOUVERS )

Reference	Parts	Quantity
GO		7

## ASSEMBLY GUIDELINES

**Step 1: Frame & Motor**

**Step 2: Assembling louvers**

**Step 3: Install louvers & Connection**

## Step 1: Frame & Motor

Notes:

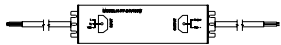

1. Please put the transformer into the side beam where is close to the motor.
2. Put the input wire of the transformer through the post, then pull the line from the notch at the base of post, to connect the power.
3. Please connect wiring in accordance with the diagram below.

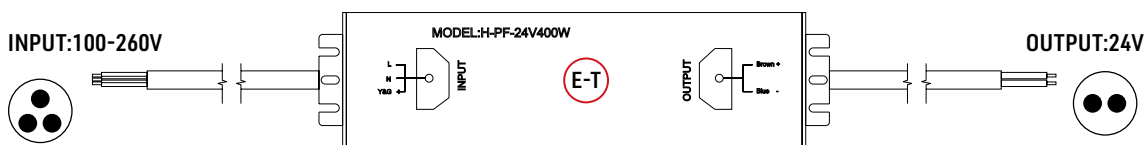
E-T	 <p>Transformer</p>	1
-----	--	---

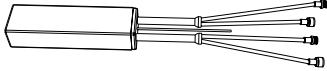

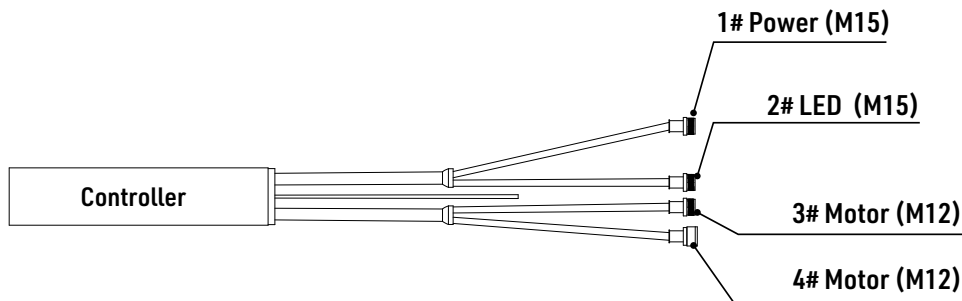
E-C	 <p>Controller</p>	1
-----	---	---

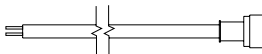

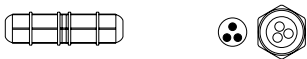
E-P		1
E-W2		1
E-W3		1



# Step 1: Frame & Motor

Motor, Controller and Transformer  
Location in the Pergola

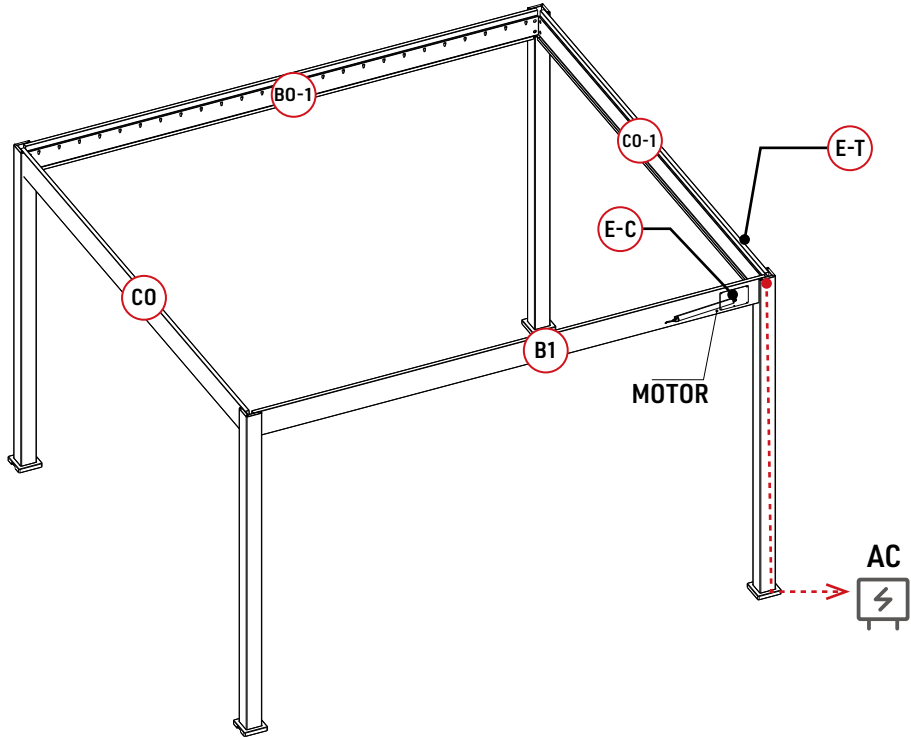



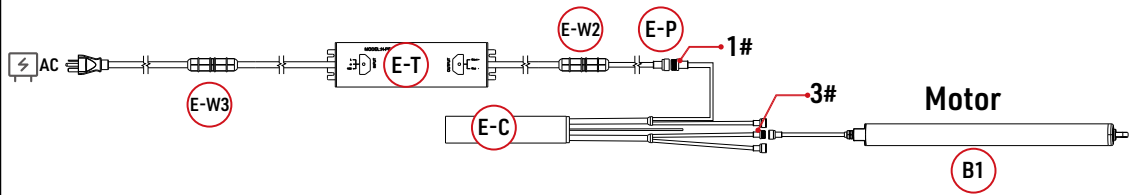

## Wiring Diagram



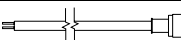

# Step 1: Frame & Motor

1-1

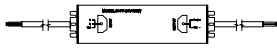
## Parts

A0		4				
E-P		1				
IO		4	XO-1		4mm	16
JO		4				
E-T		1				

## Tools

Z0-1		1
Z0-2		1

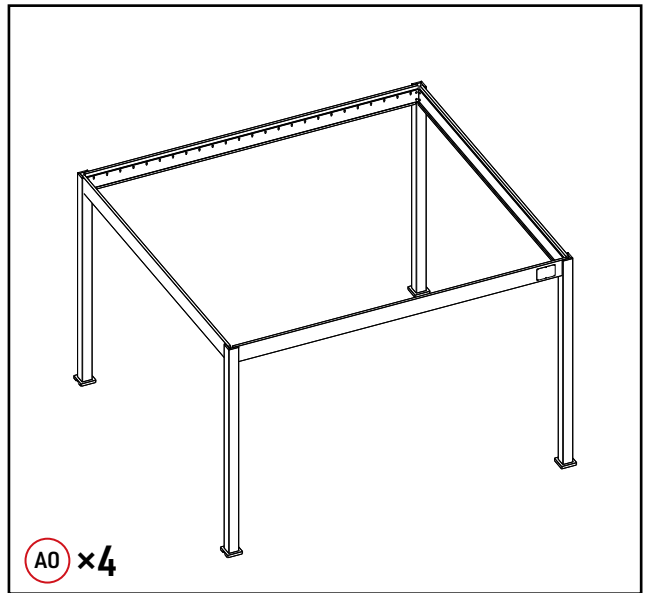

Please connect the output line(E-T) with power cable(E-P) of the transformer by using the waterproof points(E-W2).

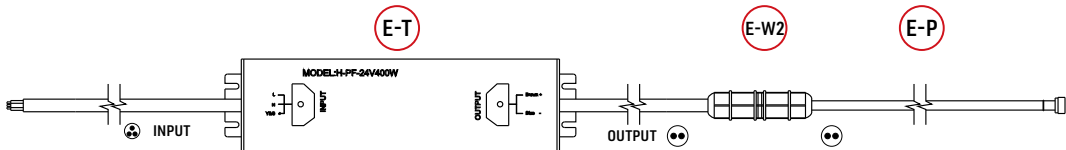

- Please insert the input line of the transformer into the cavity of the post
- Pull the input line from the drainage outlet of the post
- Install the plate and skirt of the post after pulling out the input line

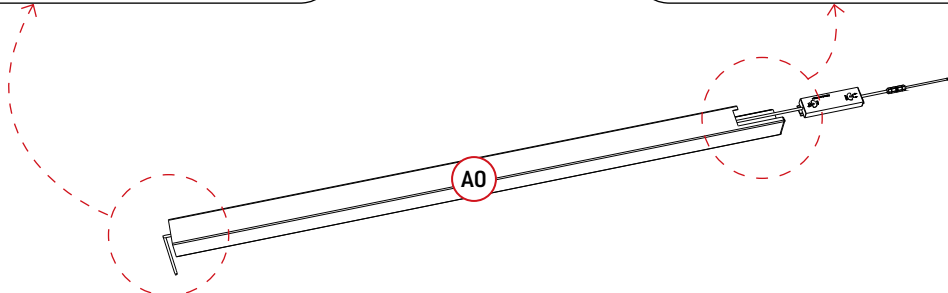
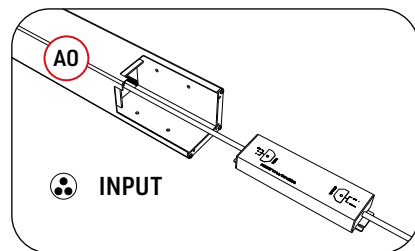
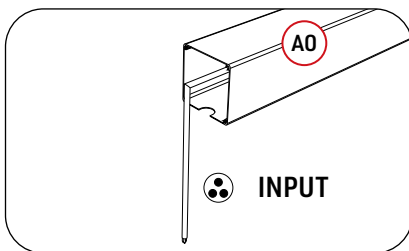

Put the skirt(I0) on the post(A0), please note that notch on the skirt and the drainage outlet of the post should be align as the diagram shows below.

1.

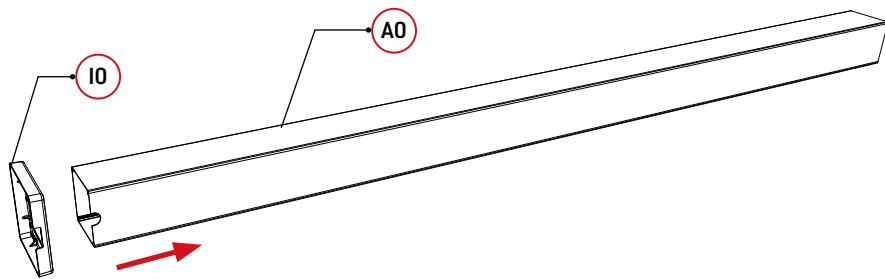

2. Install the plate

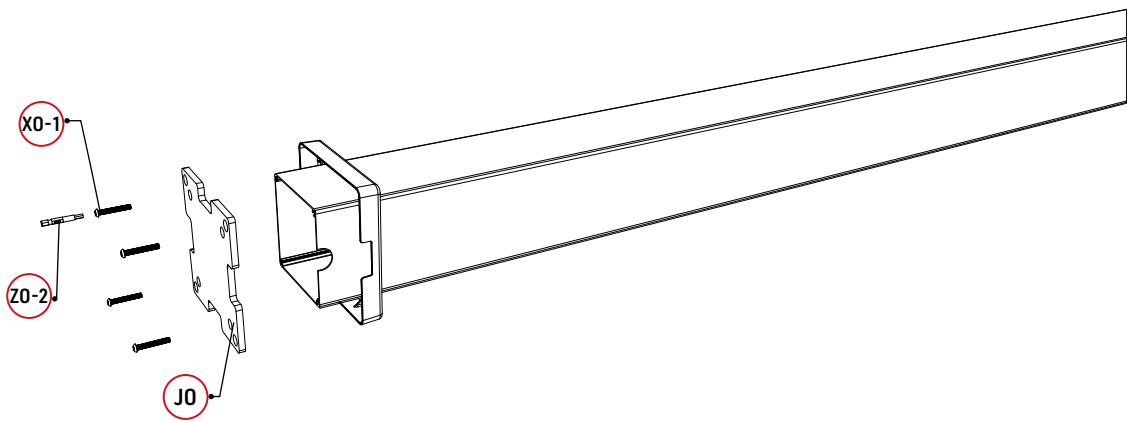

3. Tighten  
Using the pistol drill to fix screws on the plate,  
please tighten screws with the spanner.

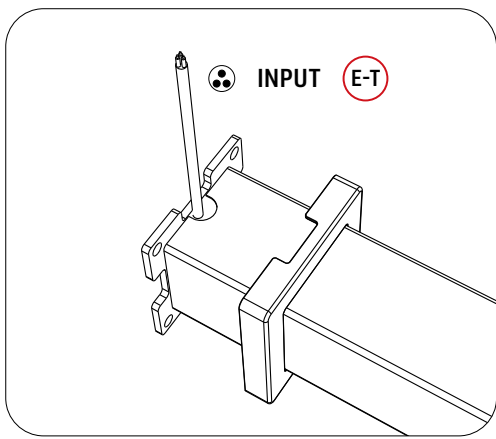
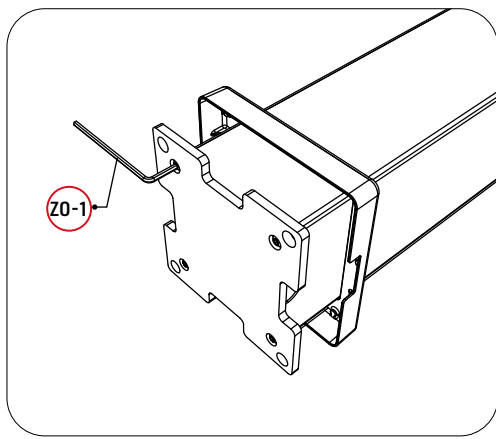

# Step 1: Frame & Motor

1-2

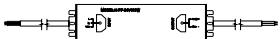

## Parts

CO		1
CO-1		1

E-T	 Transformer	1
-----	--	---

Q0	  6mm	8
----	---	---

## Tools

Z0-3	 6mm	1
Z0-4	 6mm	1

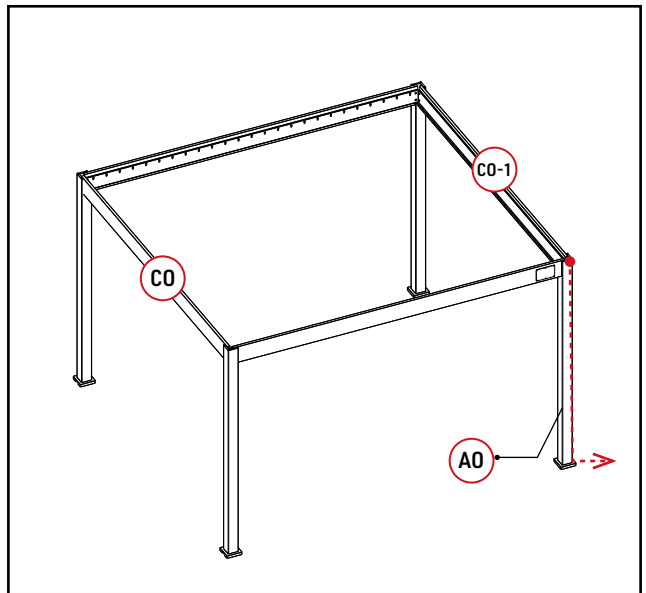

Insert the transformer into the cavity of CO-1, please note to reserve enough length of the power cable(E-P)

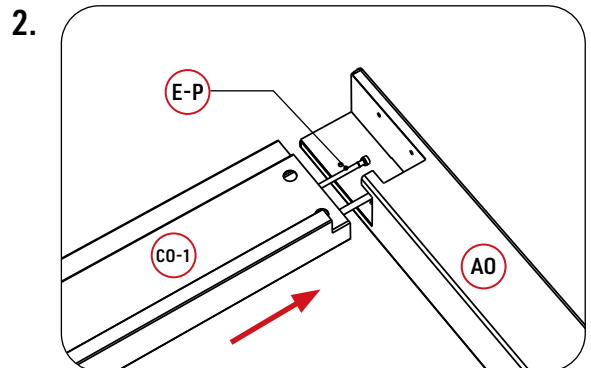
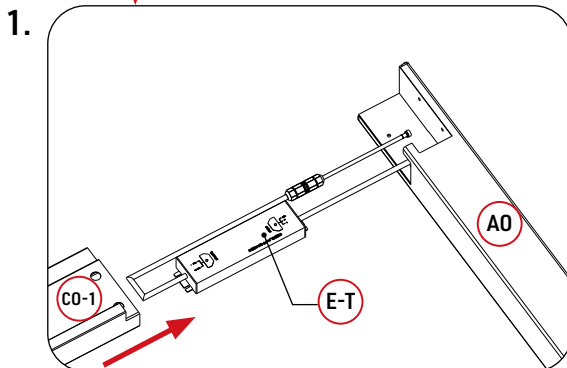
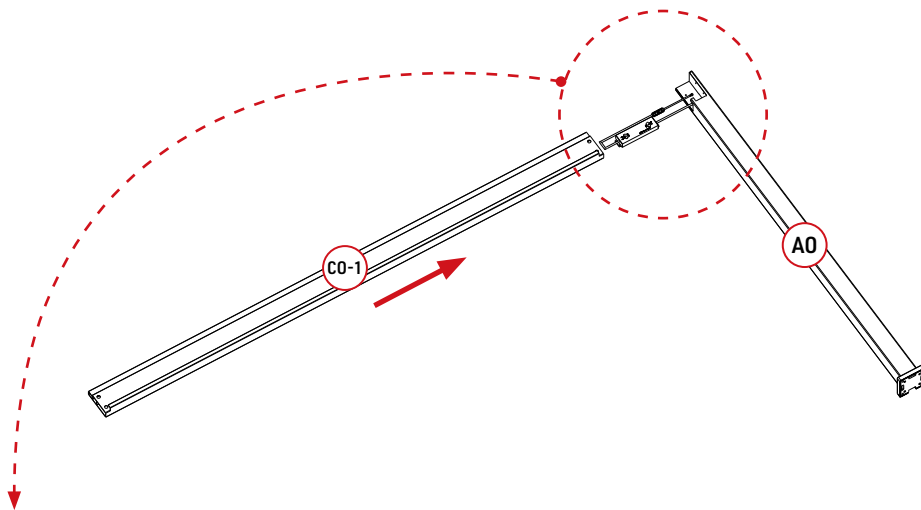

Connect the beam(CO-1) with the post(AO) as the diagram shown below.  
Please remember to keep the power cable(E-P) outside of beam

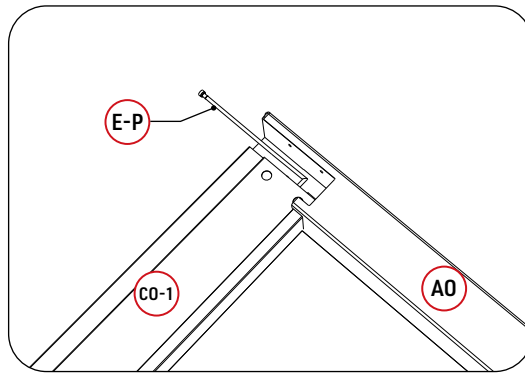

Using the pistol drill to fix screws on the post, then tighten screws with the spanner.

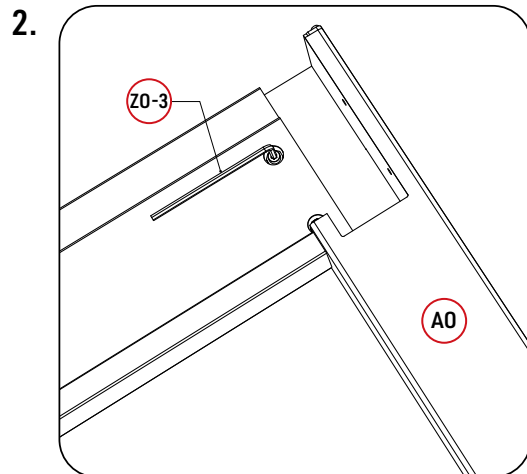
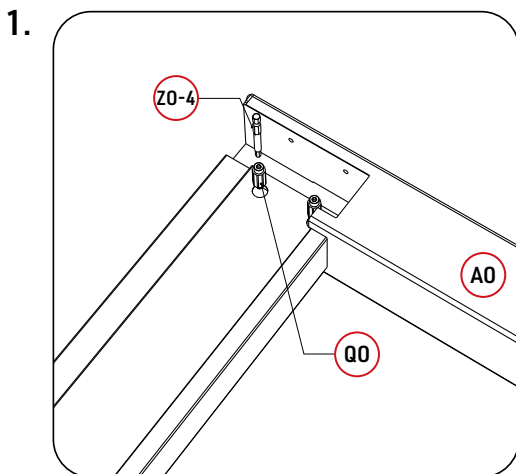
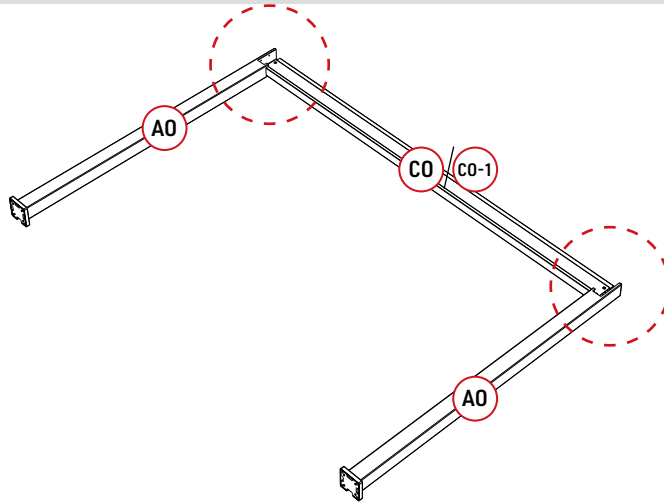

# Step 1: Frame & Motor



1-3

## Parts

B1		1
B0-1		1

Q0		8
----	---	---

## Tools

Z0-3		1
Z0-4		1

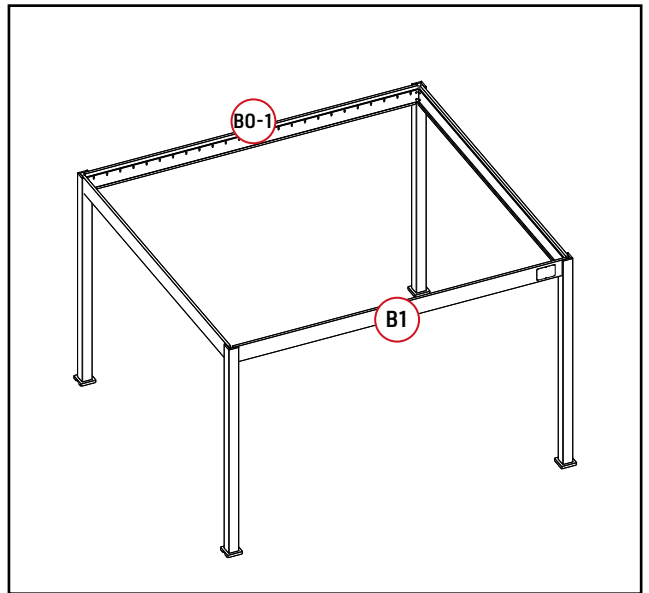

Take down the cover from the beam with the motor, then pull out the cable of the motor, and connect it to the controller

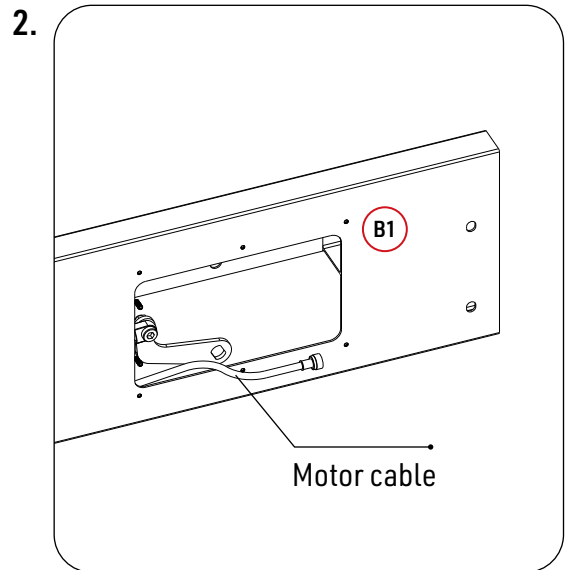
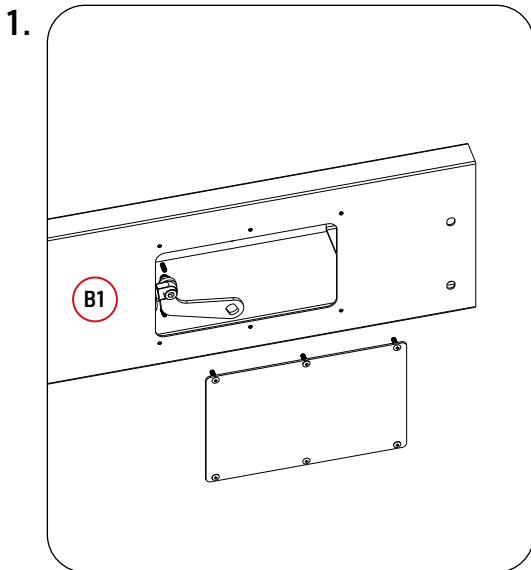
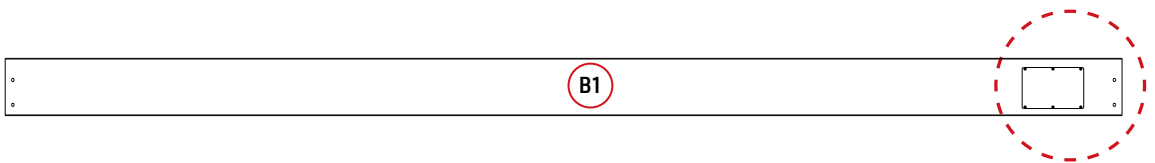

## Connect beams to posts

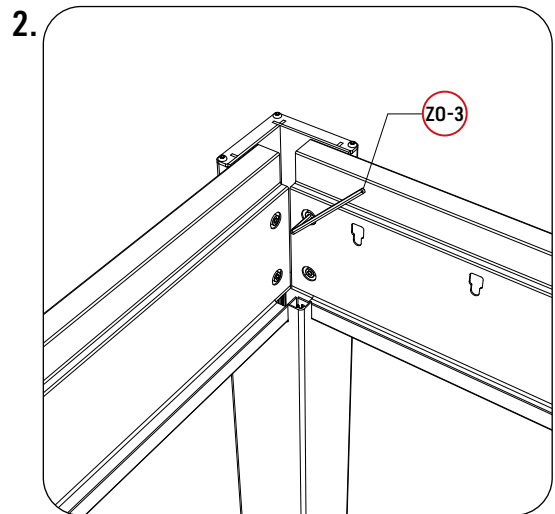
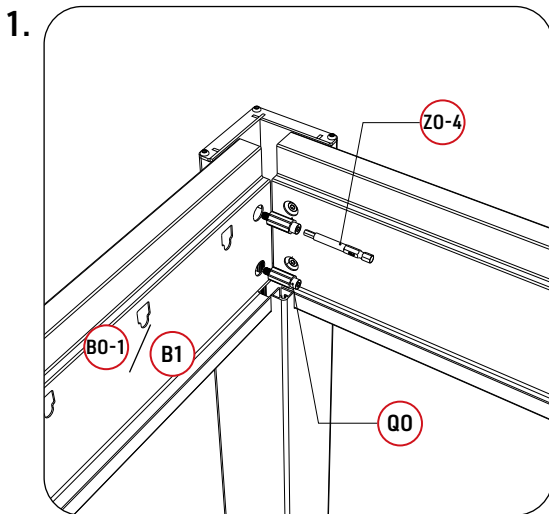
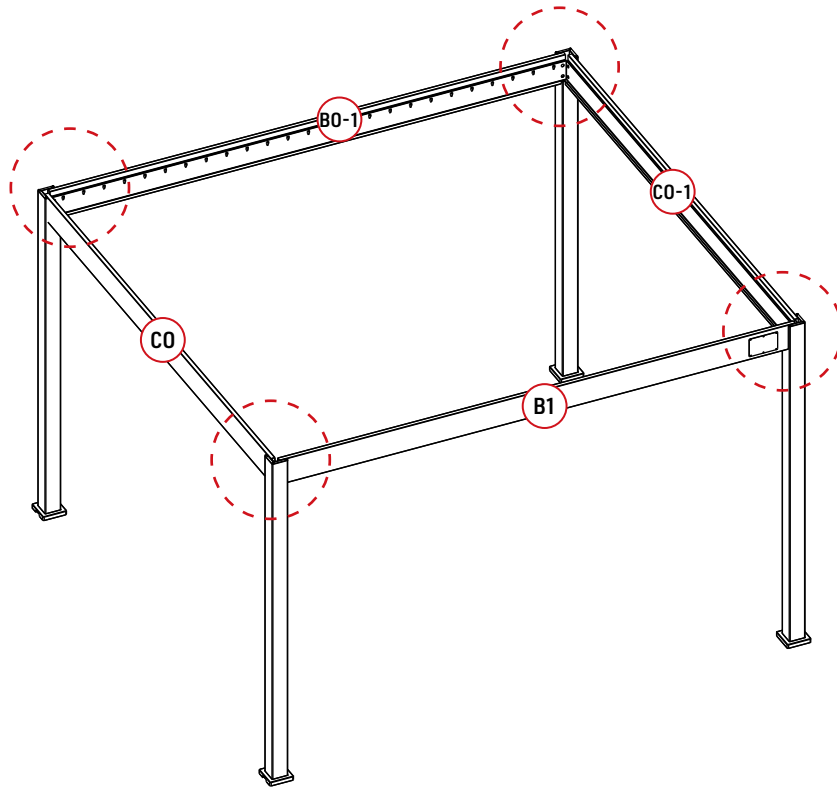

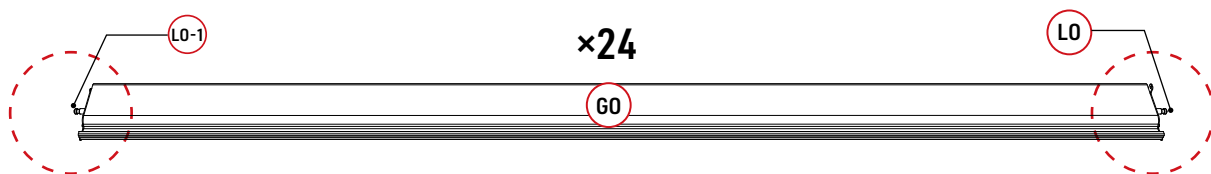
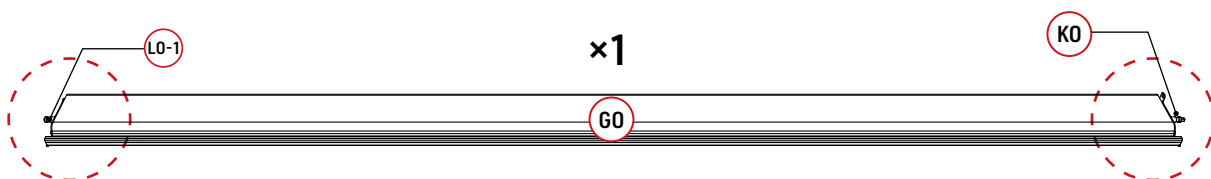
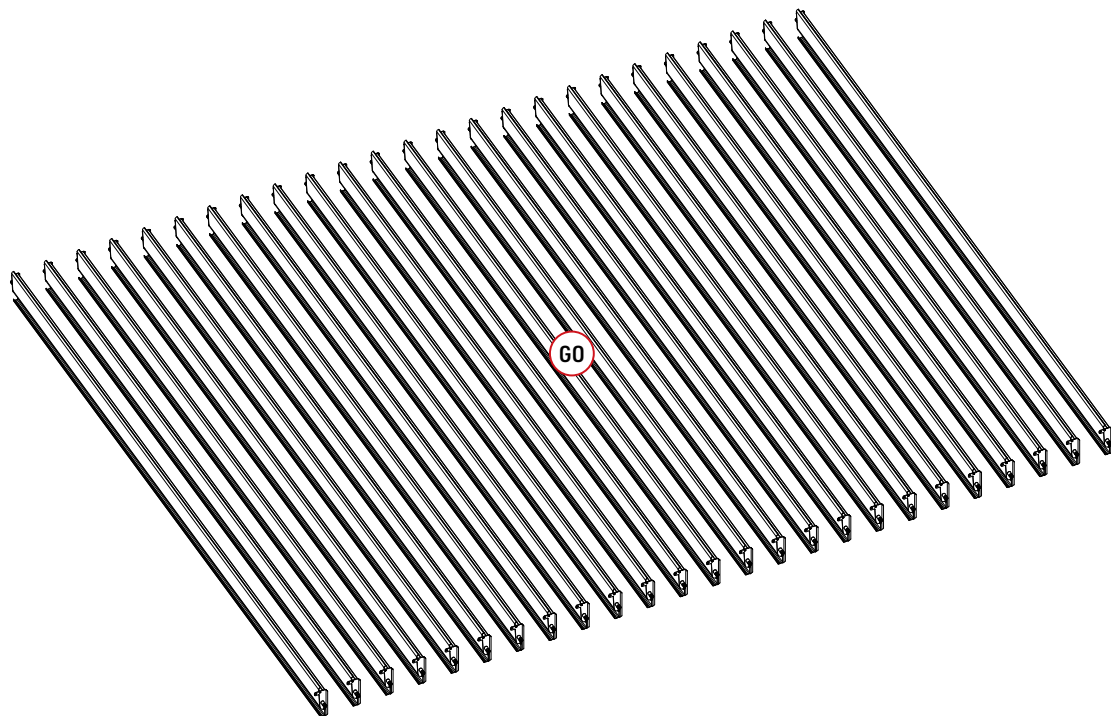

## Step 2: Assembling louvers







## Step 2: Assembling louvers 2-1

### Parts

LO		24	MO-1		49	VO		49
LO-1		25	XO		49			
MO		49	UO		49			

### Tools

ZO-3		1
ZO-4		1

**Note:** To avoid any broken of the plastic parts(MO), when use the pistol drill, please reduce the twisting force of it .

### Louver sealing plate

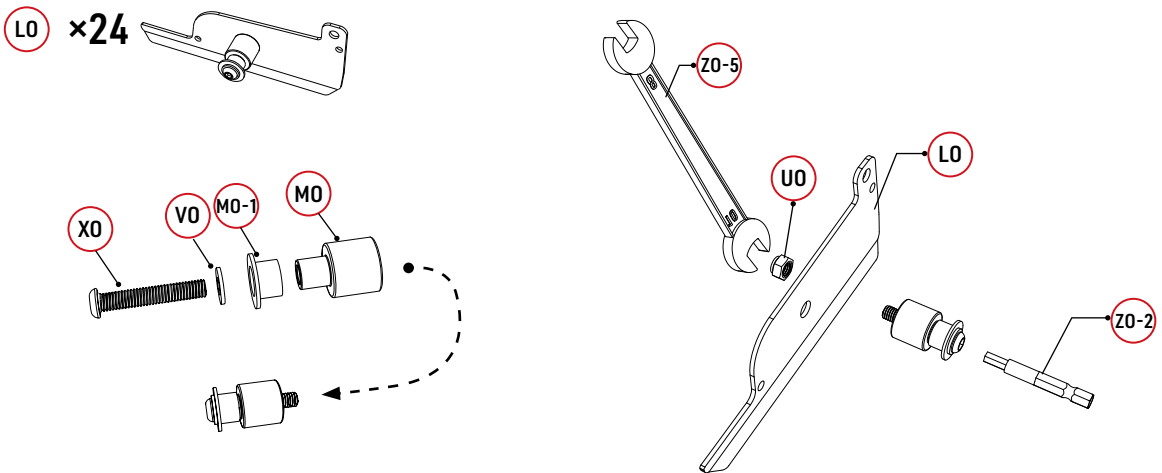



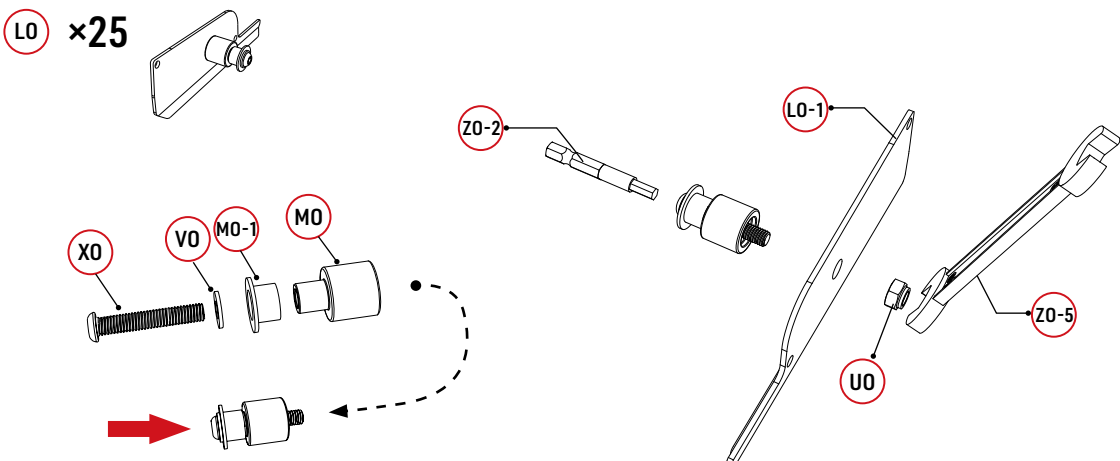



### Louver sealing plate





## Step 2: Assembling louvers 2-2

### Parts

GO		25
KO		1
LO		24
LO-1		25
WO	 	100

### Tools

ZO-1		1
ZO-2		1
ZO-6		1

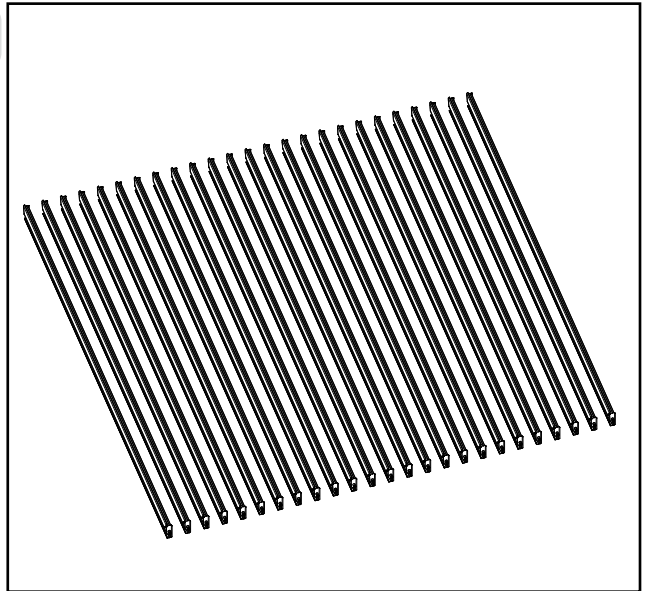

Connect end caps with the first louvre (KO)

### Completion Diagram

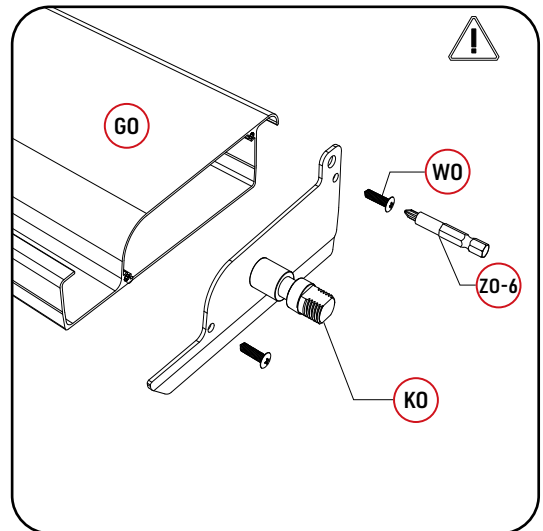
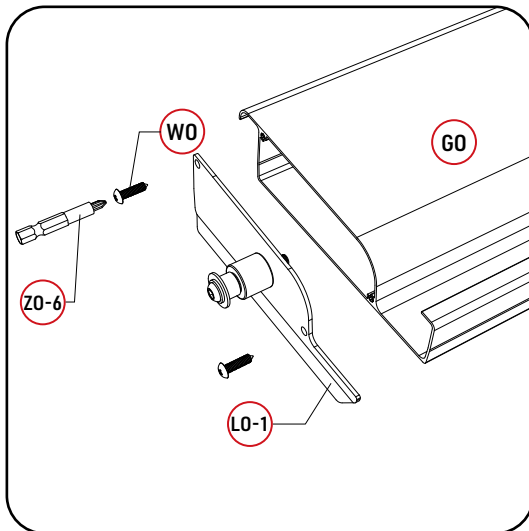
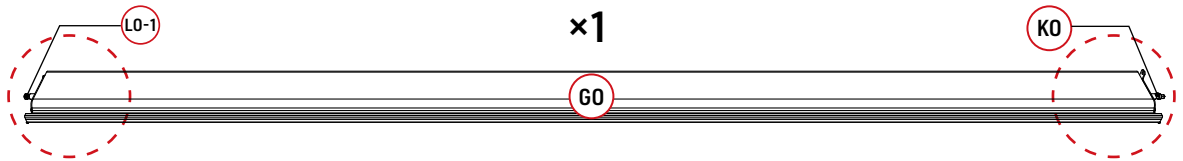

# Connect end caps with the rest louvers (LO)

## Completion Diagram

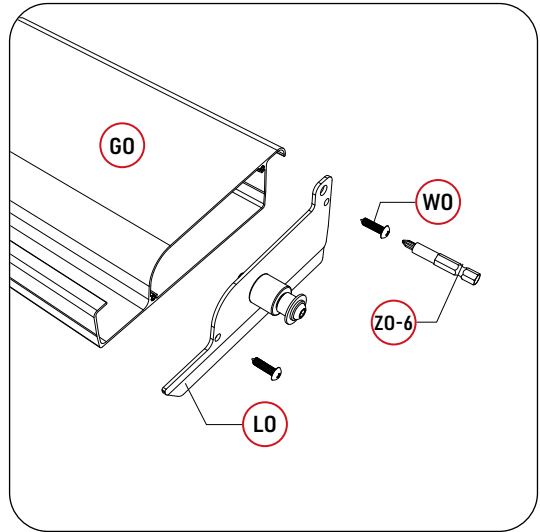
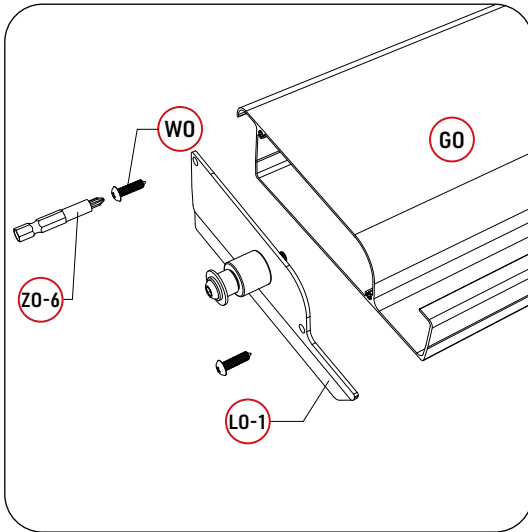
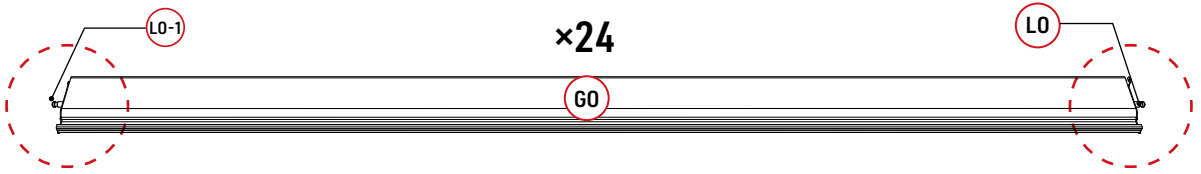

### Step 3: Install louvers & Connection

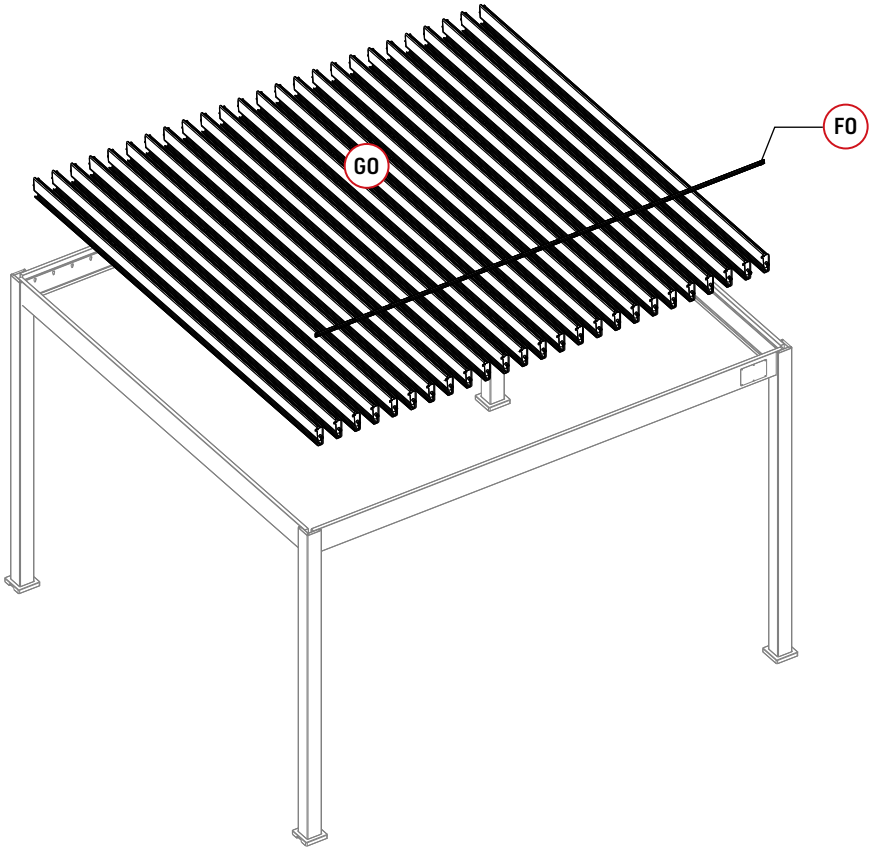

### Step 3: Install louvers & Connection

3-1

Fasten rubber plugs on both ends of the louvers

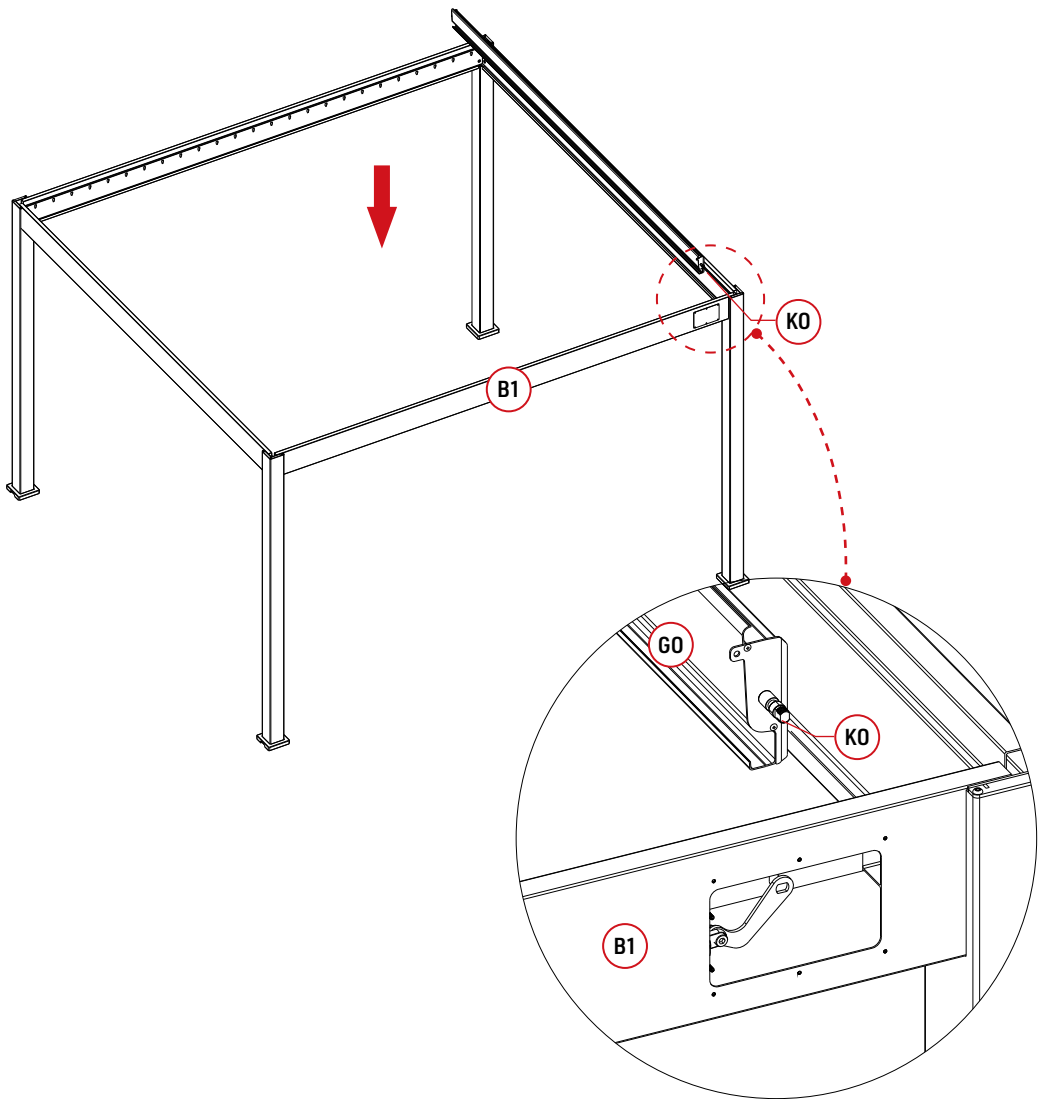

1

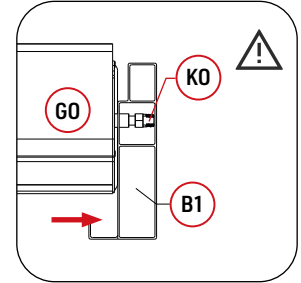
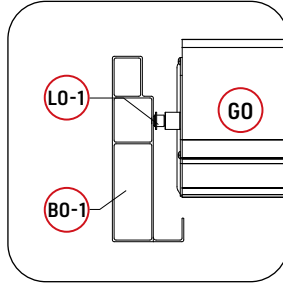
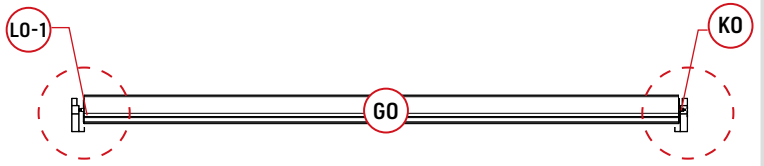
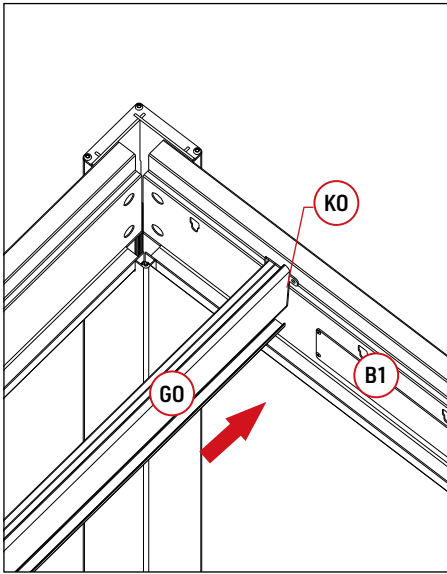

2

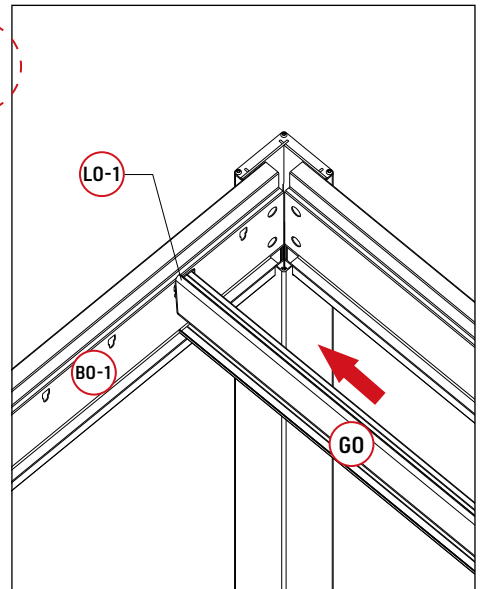
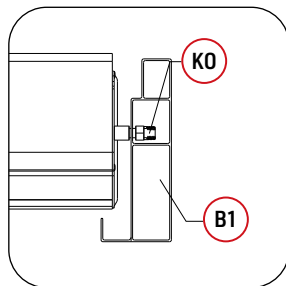
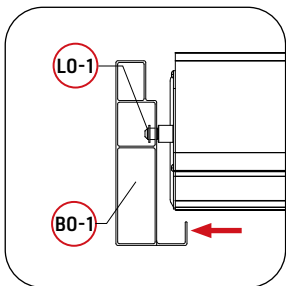
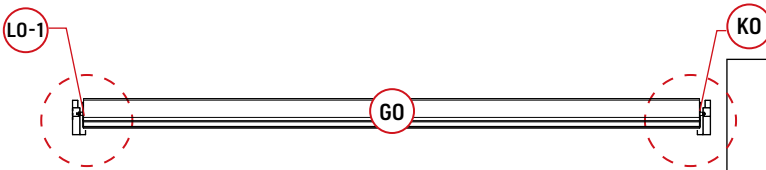

## Step 3: Install louvers & Connection

3-2

Parts

U0-3	 M14	1
------	---	---

Make the louver flat, then connect the motor rocker arm to the spindle

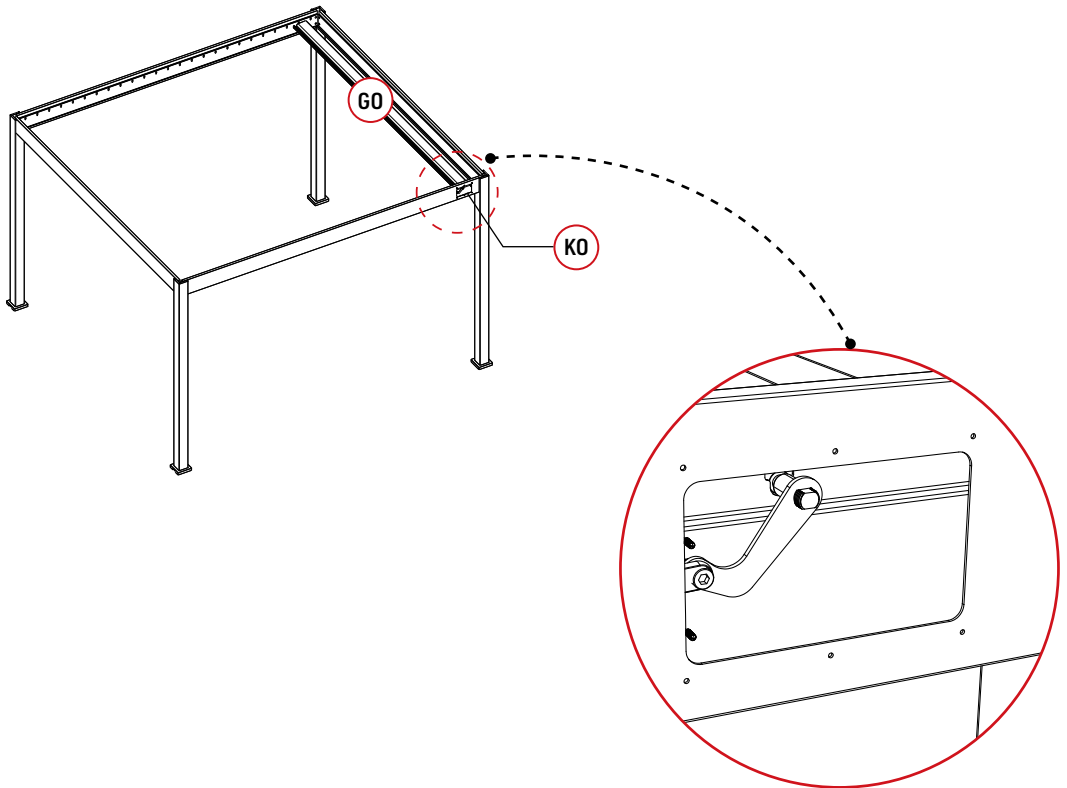

1.

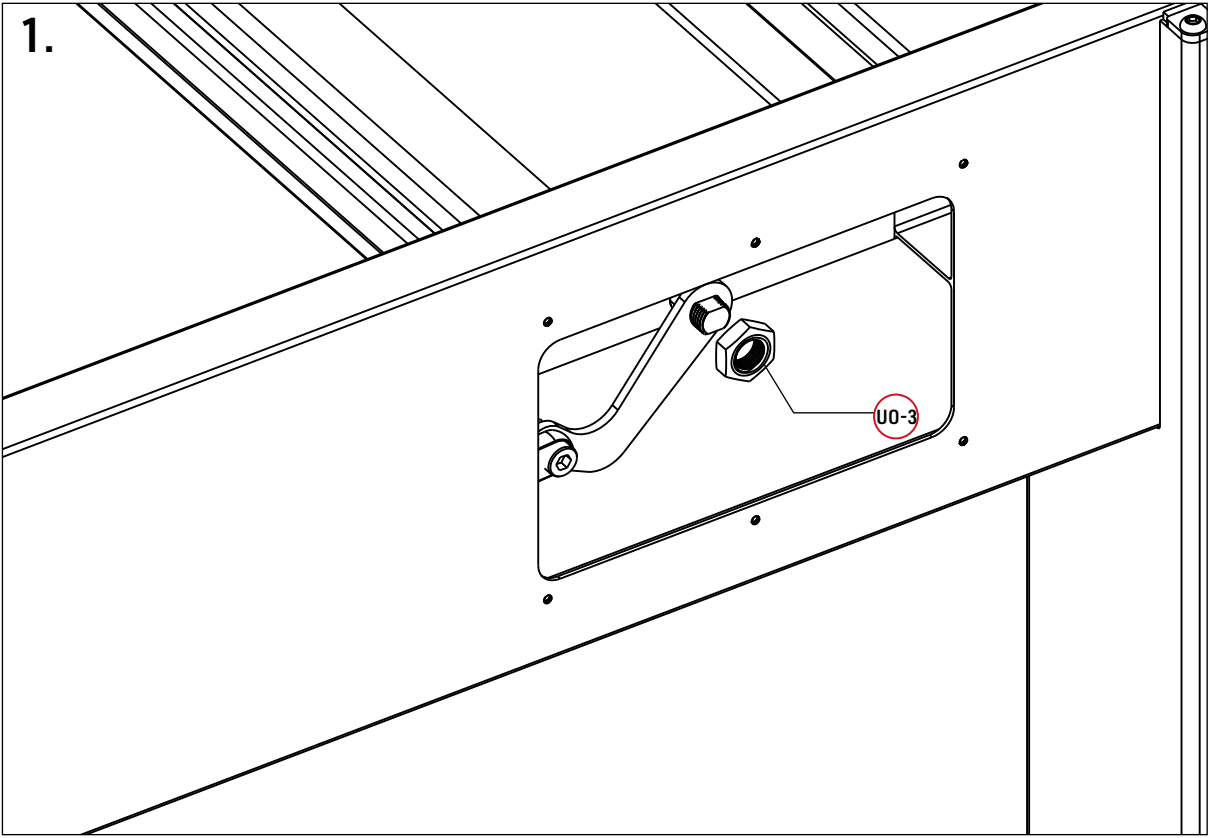

2.

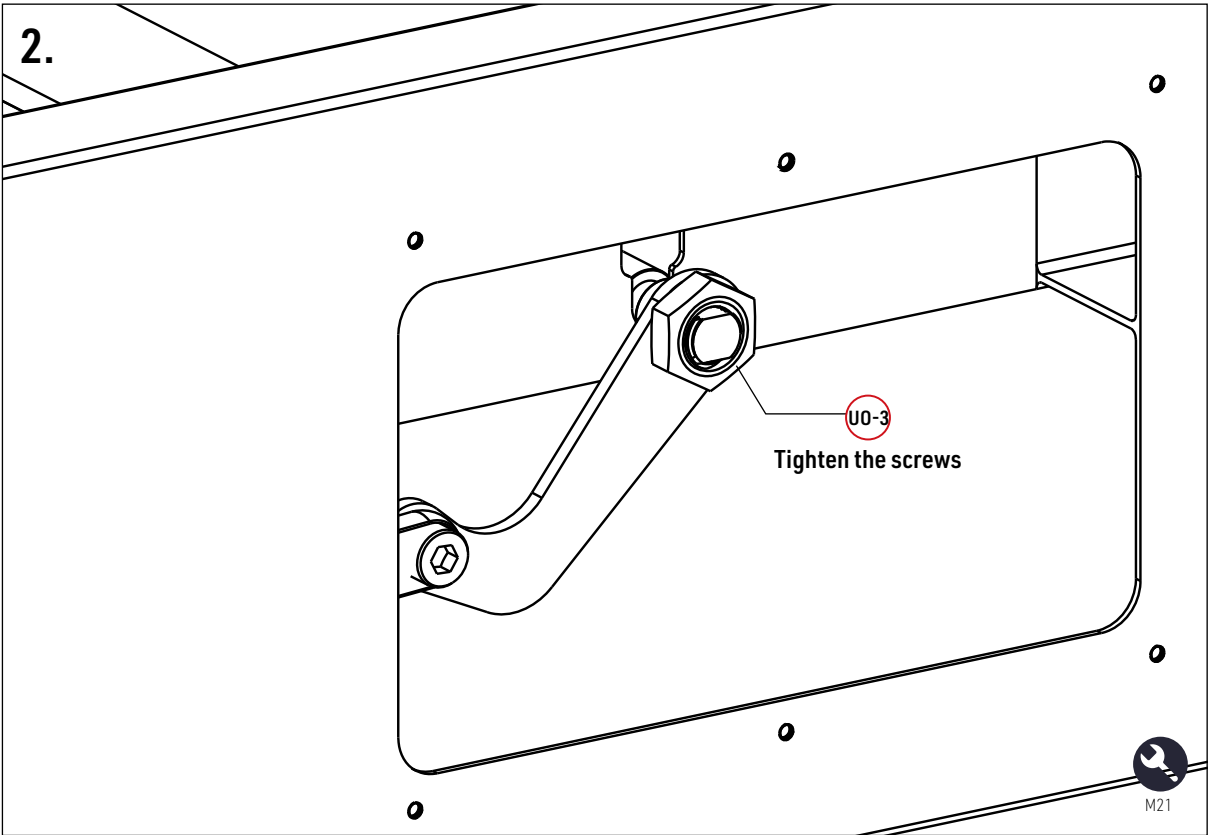



## Step 3: Install louvers & Connection

3-3

- Pull out the power cable(E-P) as the diagram shows below, then connect it with the 1# line of the controller(E-C).
- Connect the 3# line of the E-C with the cable of motor.

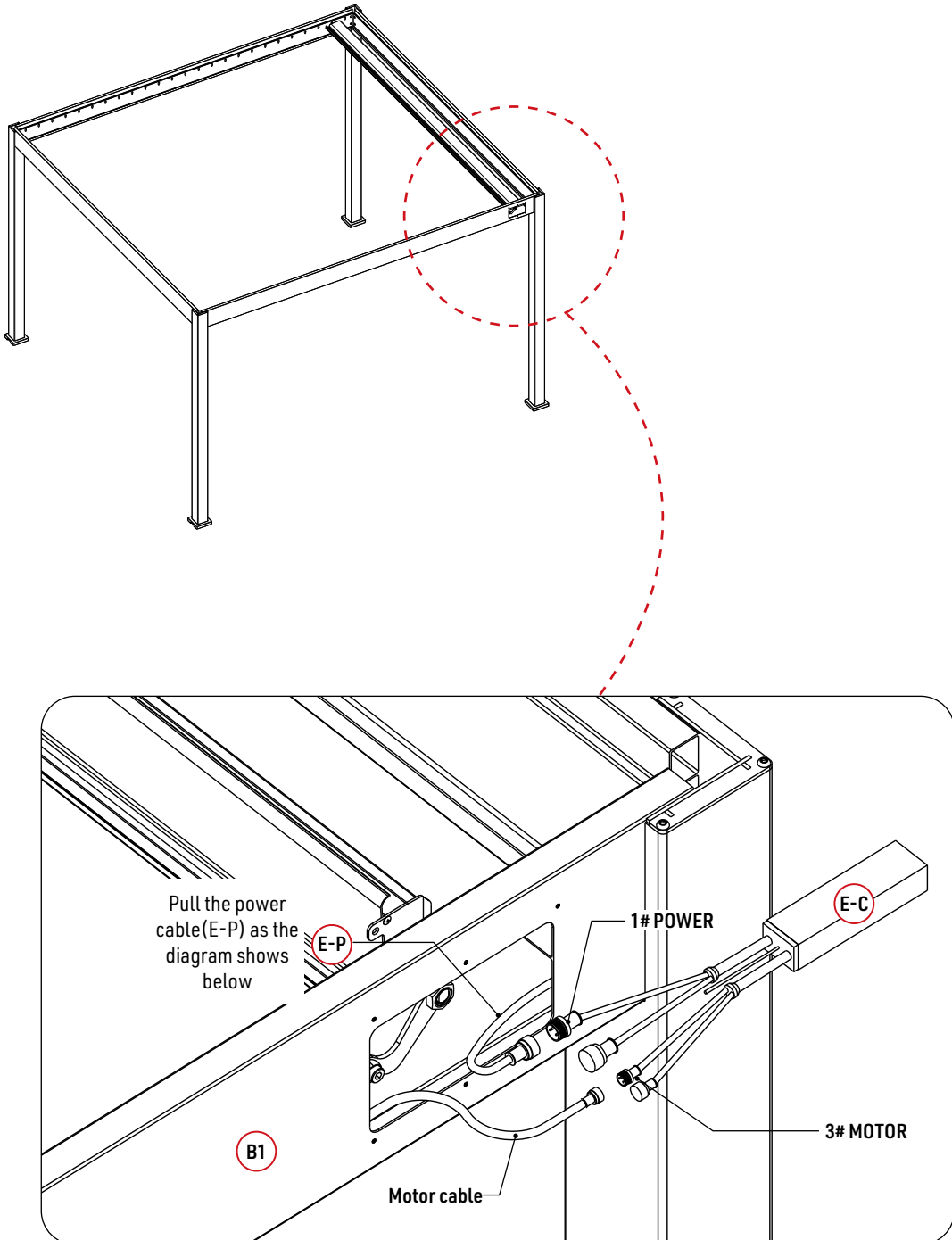

## Step 3: Install louvers & Connection

3-4

E-R		1
-----	---	---

Install the battery (purchase separately) into the remote control (E-R)

Tip. The battery model we suggest is CR2032.

### Motor link

-  1. Press the UP Button on the remote, hold this button for 3-5 seconds until the indicator becomes solid.
2. Plug in the power while press the UP button, when a slight vibration appears on the main louver, it means the remote and motor are paired.

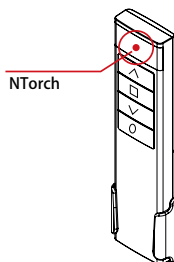
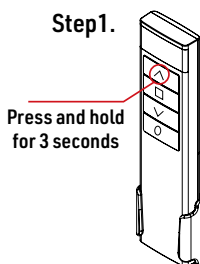

**Step2.**

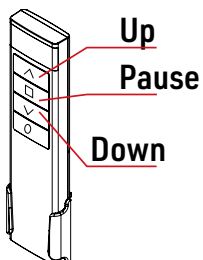
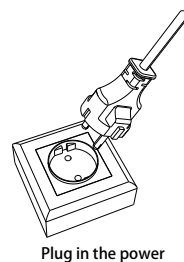

1. Check if the motor can work well, if not, please firstly check if the wiring in previous steps is correct.
2. When the motor works well, please rotate the main louvre to 90 degree, then install the rest louvres.

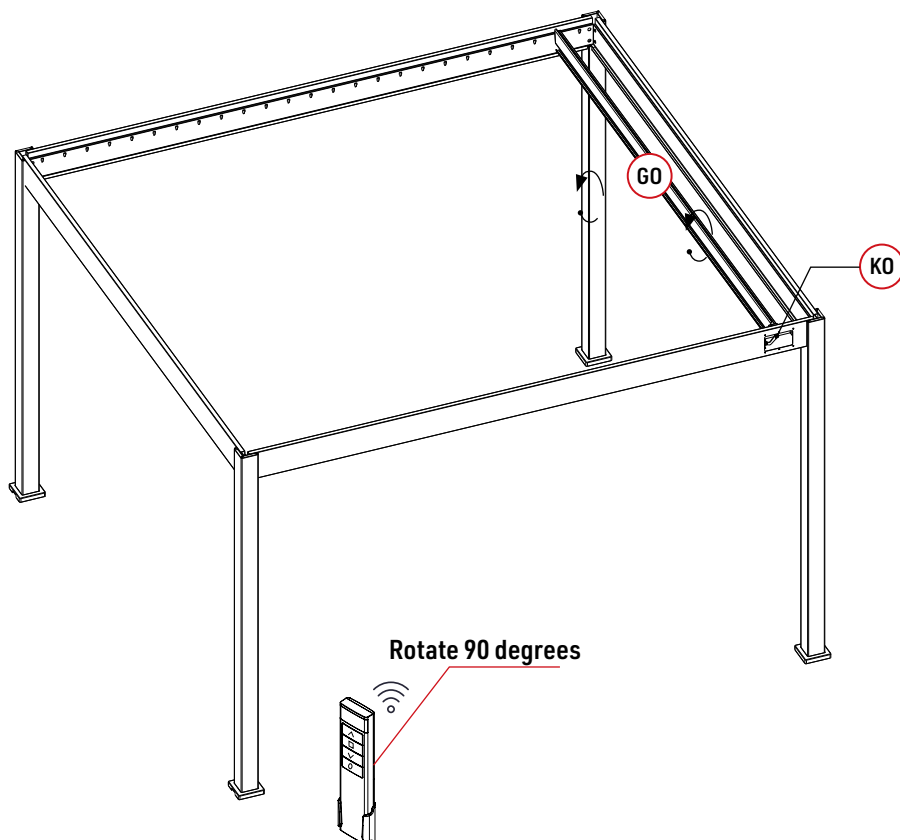

### Step 3: Install louvers & Connection

LED

Insert the LED strip into the gutter

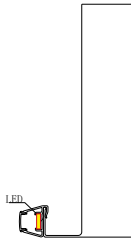

Put the output line of the LED controller(L-C1) into the cavity of the post.

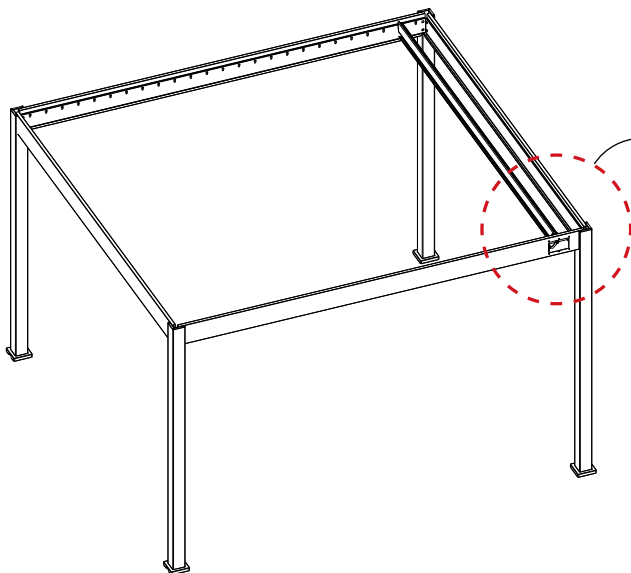
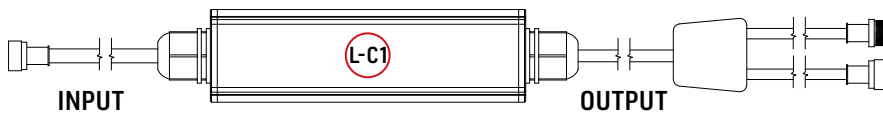

1.

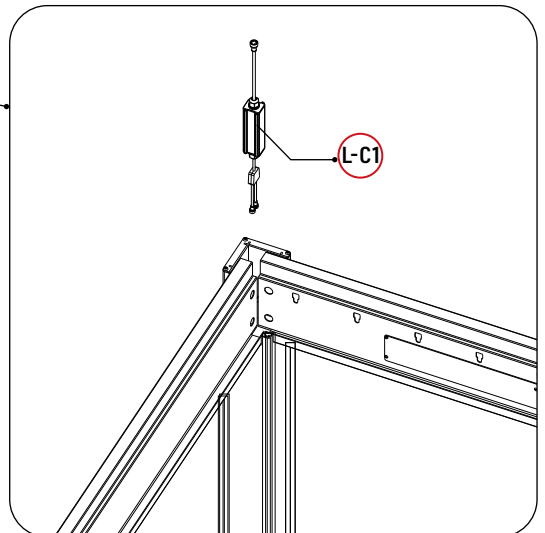

Please note that the Input End of the LED controller should be in the upward direction while the Output End should be in the downward direction.  
For the two cable of the Output End, please pull them from the drainage notch by using the supplied brush.

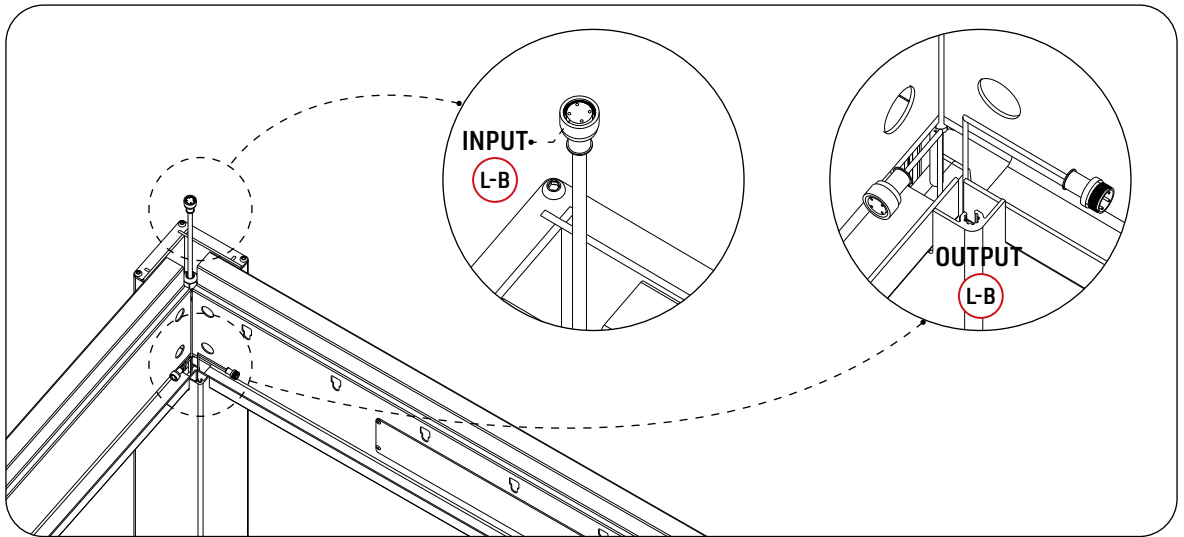

Connect the Input line of the LED controller(L-C1) with the 2# LED of the Controller(E-C).

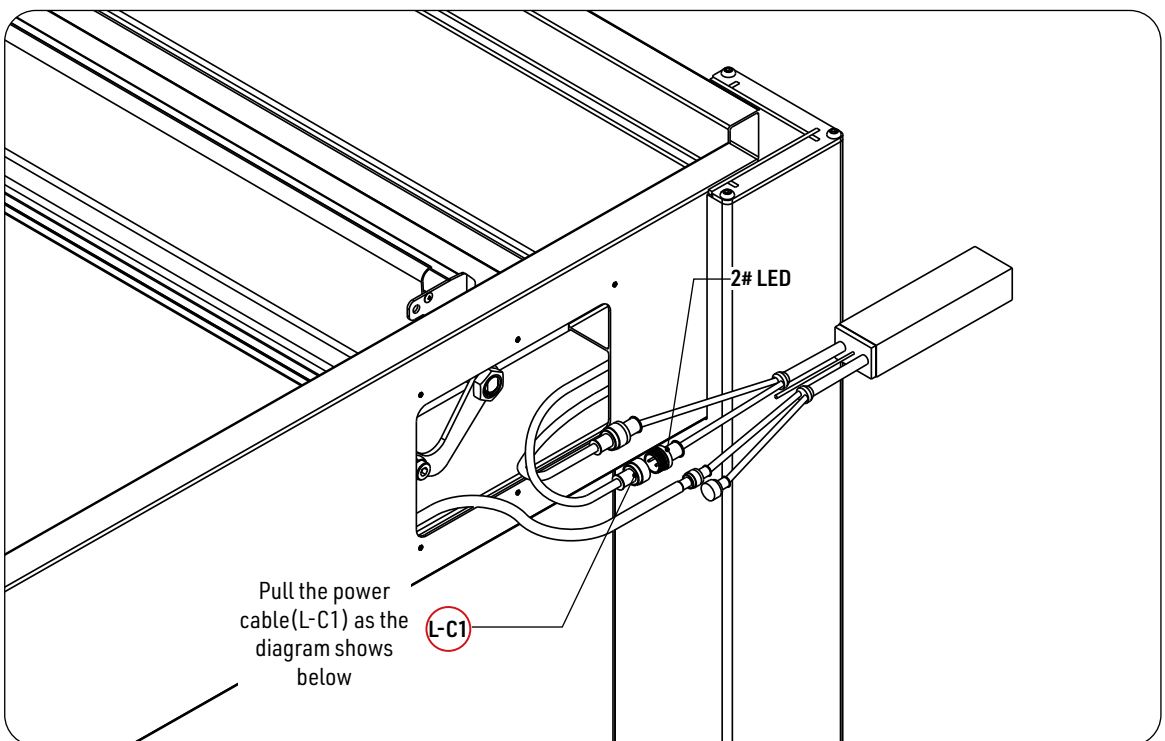

### Step 3: Install louvers & Connection

LED

Install all LED strip in series, then connect the two ends of the LED strip with the two output line of the LED Controller(L-C1)

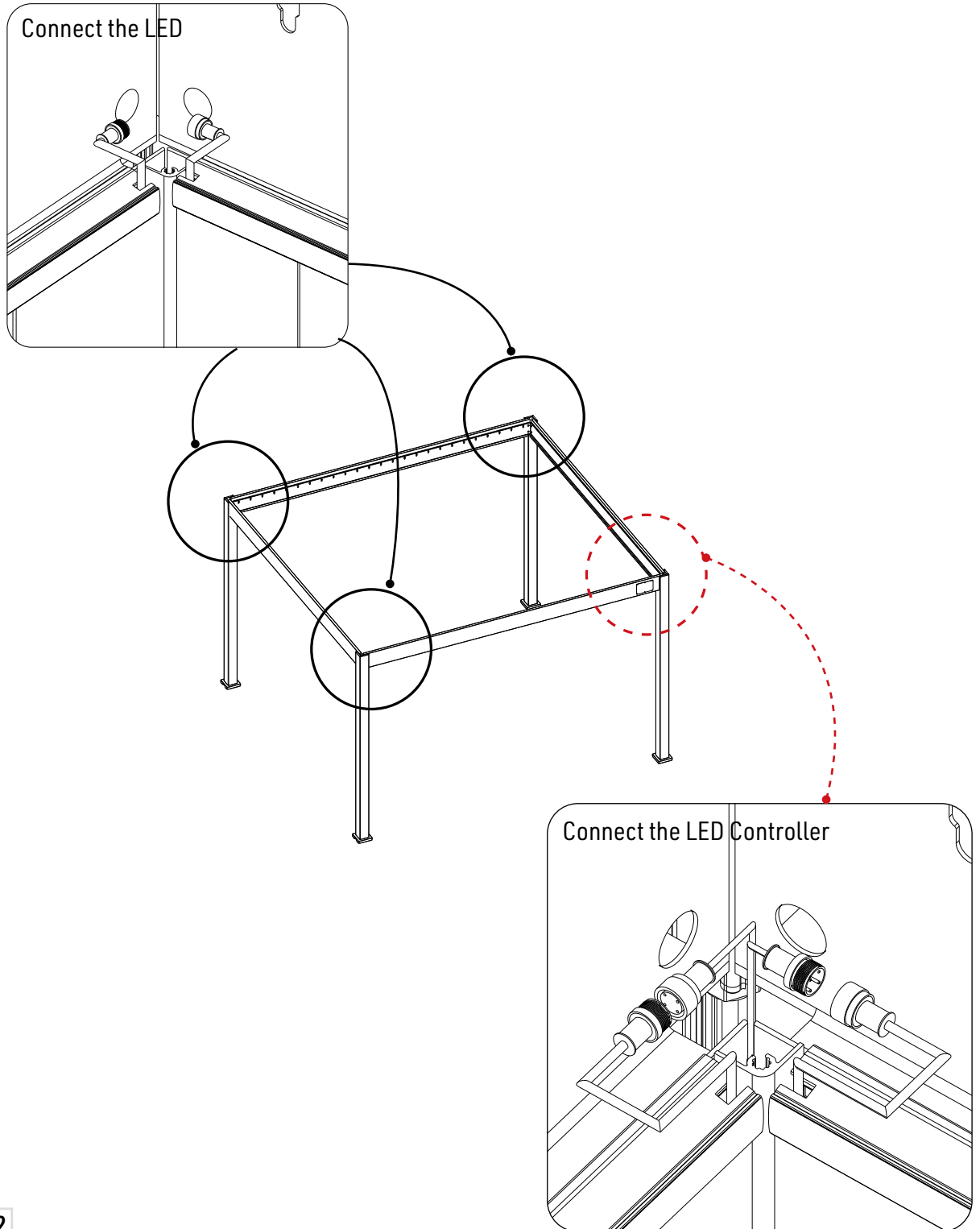

## Step 3: Install louvers & Connection

LED

The remote controller has the functions below:

- Control the ON and OFF of the LED
- Control the rotation of the louvre

If you need to control the LED color, please download the APP below.

LED color control can only be available when you have access to WIFI



Tuya Smart

Tuya APP network connection

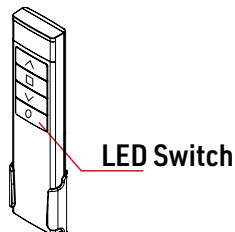

If the LED cannot be connected when powered on, please reset the controller of the LED

Repeat power on and off for 5 consecutive times,  
also clear previous network connection, enter Smart cong mode, the output LED will ash 10 times.

## Step 3: Install louvers & Connection

3-5

After connecting all cables and adjusting of LED strip, louver rotation, please put the Controller(E-C) into the cavity of the beam(B1) as the diagram shows below.

To avoid any struck of cables, please note that the Controller(E-C) and all cables should be keep away from the movement range of the Motor's swing arm.

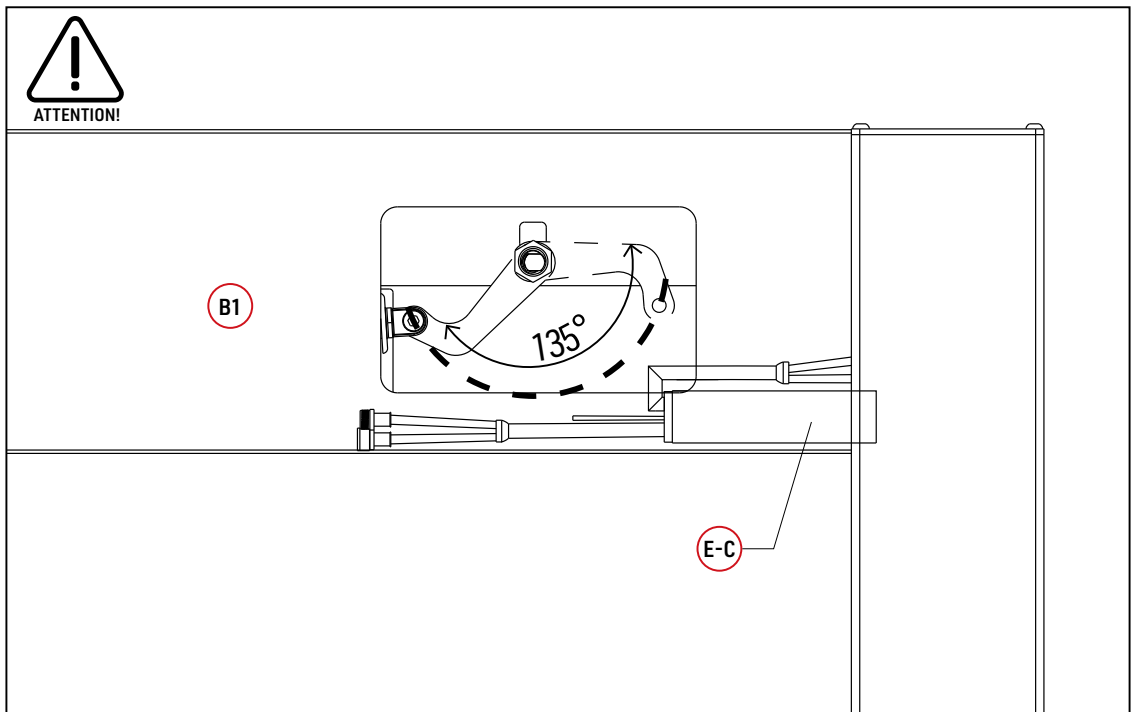



## Step 3: Install louvers & Connection

3-6

Parts

S0		50
----	---	----

1. Install other louvers on the beam and make the louver flat
2. Cover the screw head with plastic caps

1

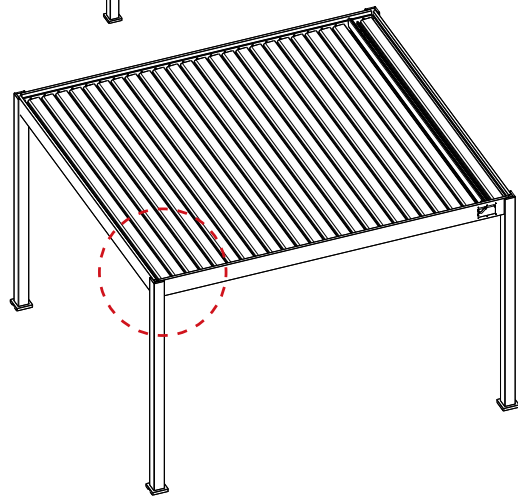
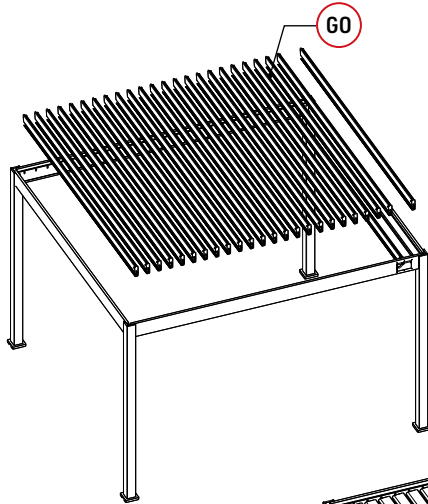



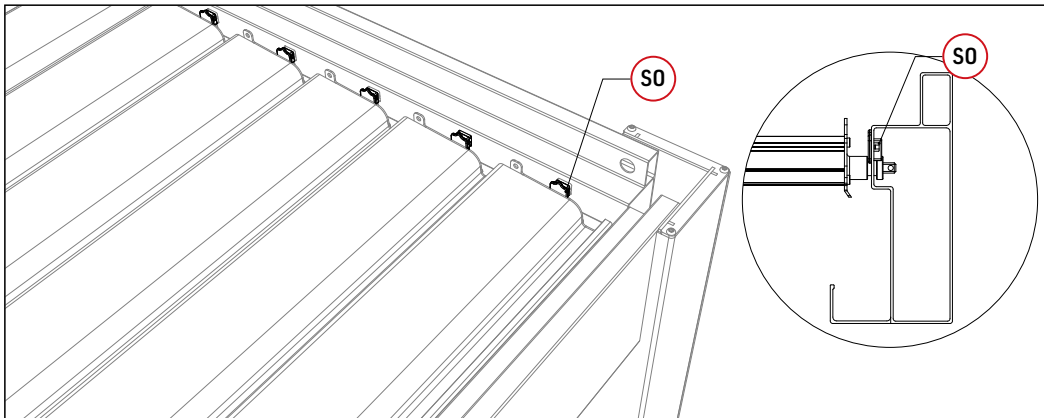

2



# Step 3: Install louvers & Connection

3-7

## Parts

F0		1
X0-2		25
V0		75
U0	 lock nut	25
U0-1	 plastic nut	25

## Tools

Z0-1		1
Z0-2		1
Z0-5		1

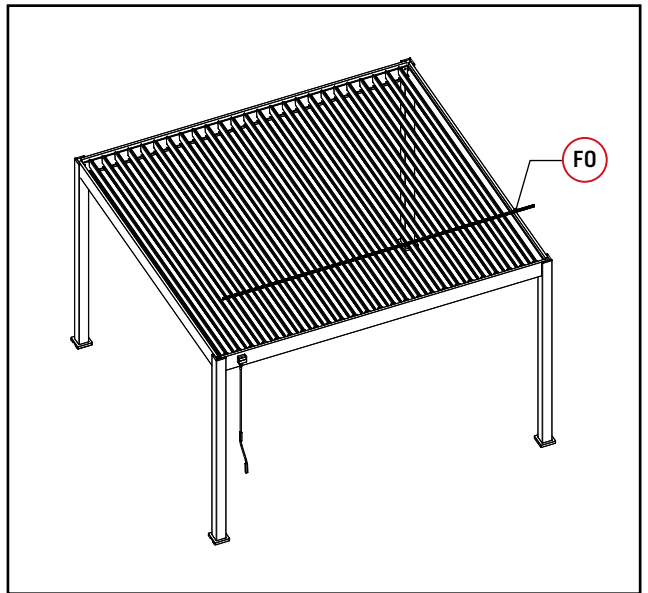

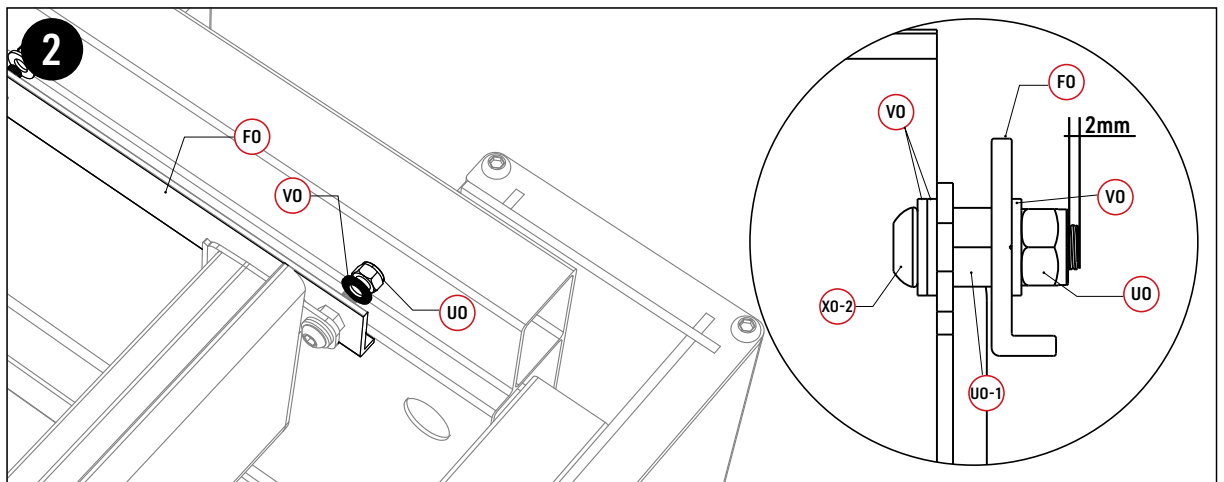
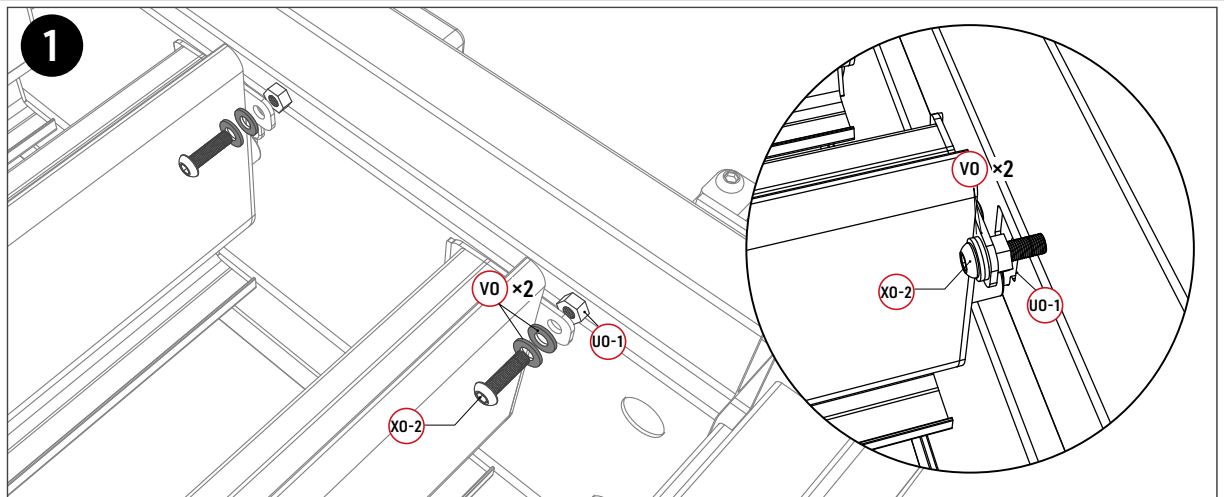

Install the connecting bar



## Step 3: Install louvers & Connection

3-8

### Parts

RO		16
TO	 10x80	16

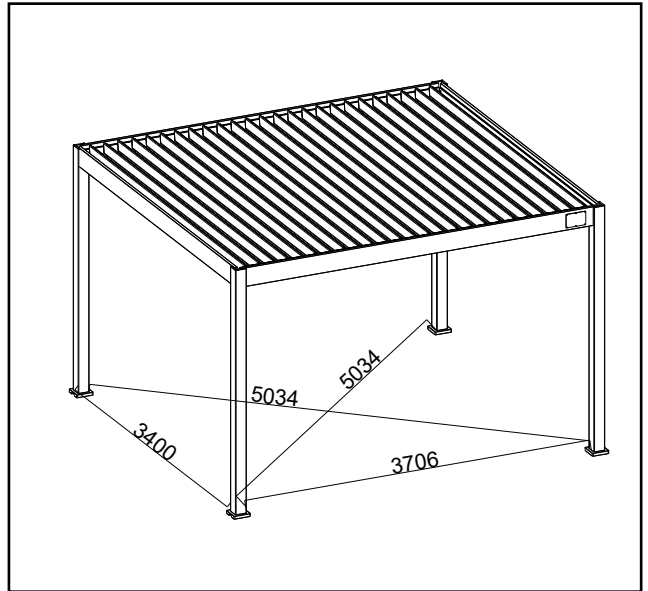

Cover the screw head with plastic caps

1

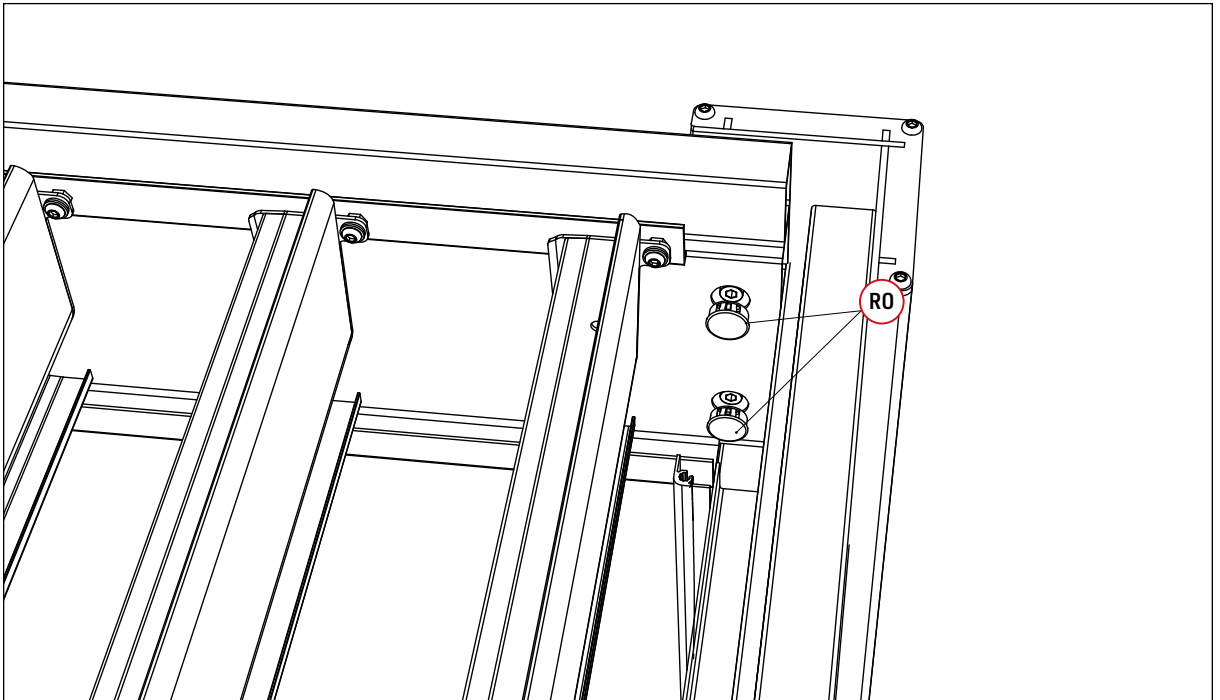

2

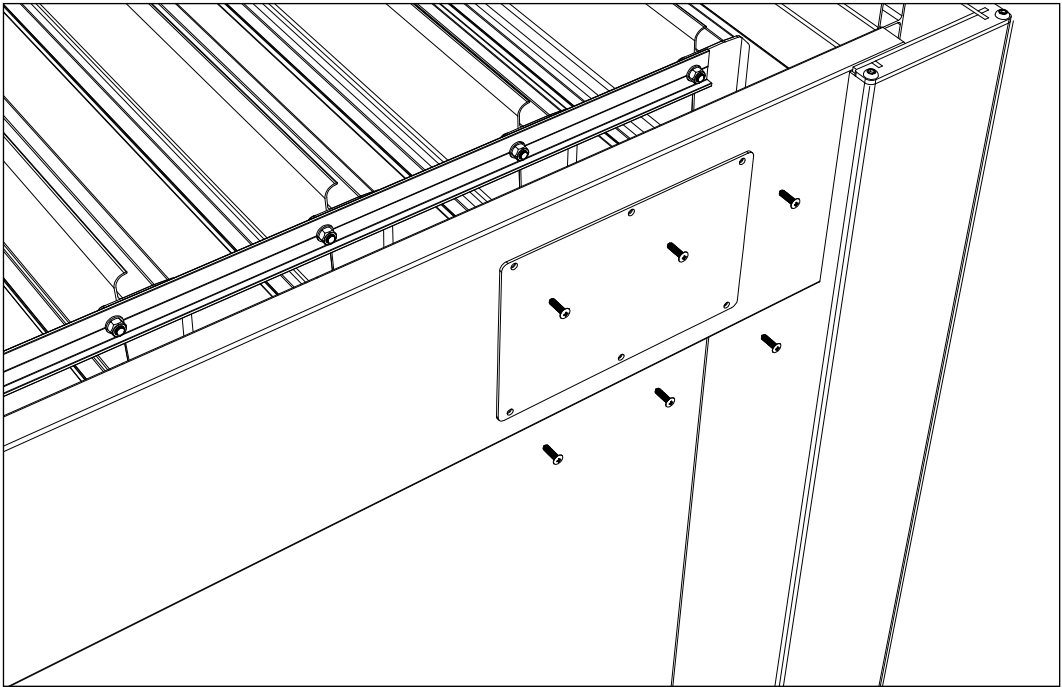

3



Please check all footing dimension are correct, then fix all base plates.

