

3x6 Meter Pergola elektrisch, Aluminium

Montageanleitung - DE

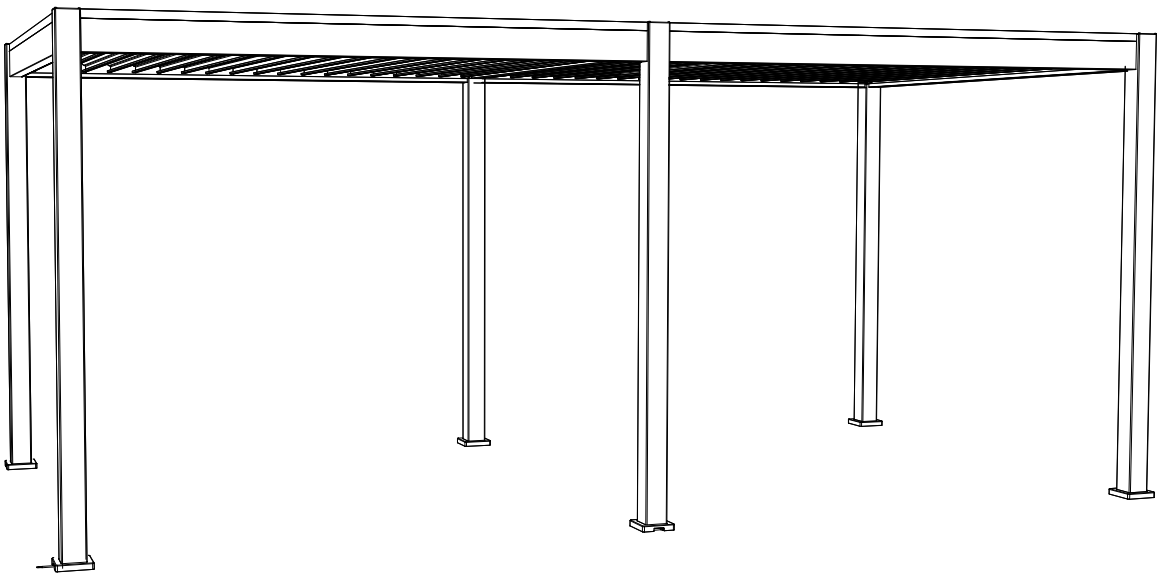
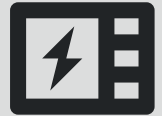

E-Deluxe Aluminium Pergola 3×6 Meter

Bewahren Sie die Anleitung während der gesamten Lebensdauer des Produkts auf. Bitte lesen Sie die Anleitung vor dem Zusammenbau aufmerksam durch. Der Nutzer haftet für Schäden oder Verletzungen, die durch unsachgemäße Verwendung verursacht werden.

Zusätzlich benötigte Werkzeuge und Sicherheitskleidung für die Installation (nicht enthalten)



Sicherheitsbrille und Arbeitshandschuhe



2 x Leiter



Bohrmaschine
+ 12 mm Bohrer



Akkuschrauber

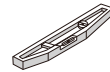

Wasserwaage



Cuttermesser



Sicherheitshelm

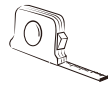

Maßband

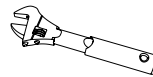

Schraubenschlüssel

2D Fundamentmessung (Dimension in mm)

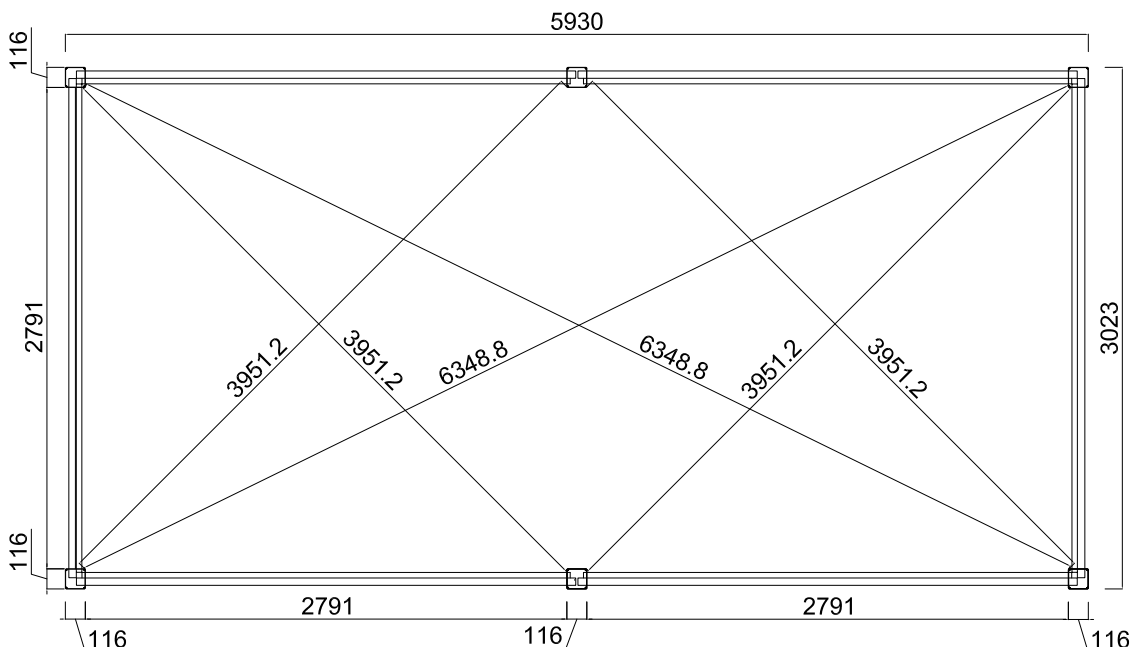

3D-Fundamentmessung (Dimension in mm)

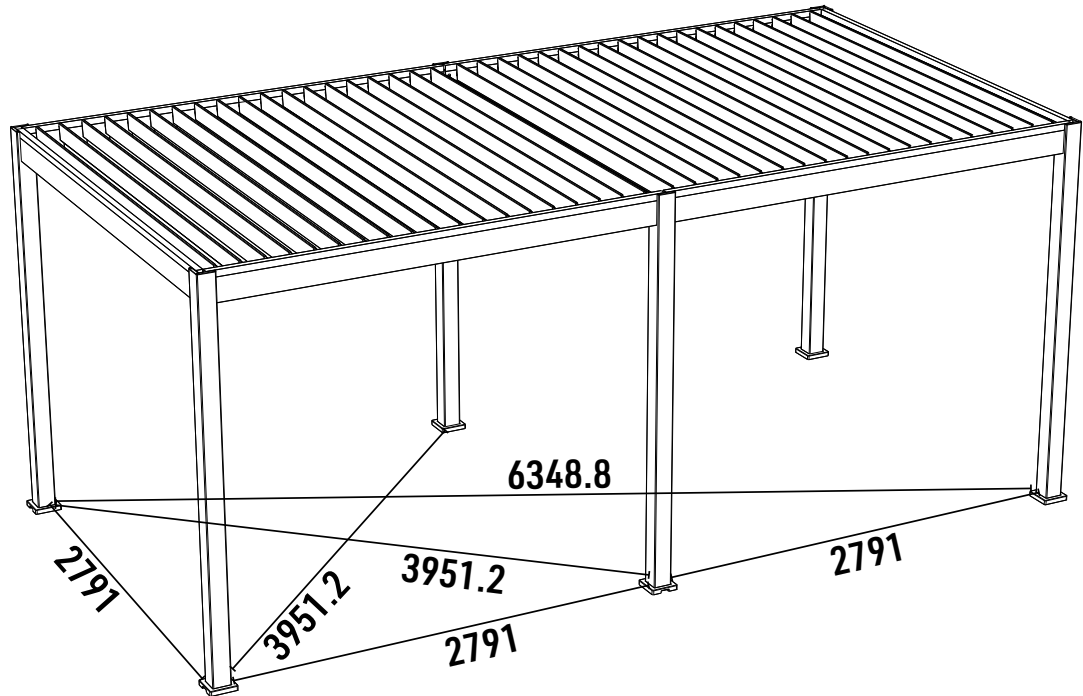

VORSICHTSHINWEISE FÜR DEN GEBRAUCH

Dieses Produkt sollte nicht bei extremen Wetterbedingungen verwendet werden: Stürme, heftiger Wind, Hagel und Schnee. Wir garantieren die Beständigkeit der Pergola für Windgeschwindigkeiten bis zu 88 km/h und eine maximale Schneelast von 50 kg/m².

Bei starkem Schneefall oder Wind, weisen wir ausdrücklich darauf hin die Lamellen zu öffnen. Bitte nicht vergessen, den Schnee vom Dach zu entfernen, um eine starke Überlastung vom Dach zu vermeiden.

Unsere Pergola kann starke Regenfälle standhalten, aber wir können keine absolute Wasserdichtigkeit garantieren. Bei außergewöhnlichen Wetterereignissen kann die Wasserdichtigkeit beeinträchtigt werden. Lassen Sie keine feuchtigkeitsempfindlichen Produkte unter der Pergola stehen.

Wir raten davon ab, auf das Dach oder das Gestell der Pergola zu klettern. Es besteht die Gefahr von Schäden und Verletzungen.

Tipps und Sicherheitshinweise

Je nach Standort und Fläche kann es sein, dass für den Bau eine Baugenehmigung oder ein Antrag auf Baugenehmigung erforderlich ist. Wir empfehlen Ihnen vor dem Aufbau sich an Ihre Stadtverwaltung zu wenden, um die entsprechenden Informationen zu erhalten.

Produktmontage:

- Es werden 2-3 Personen benötigt
- Entfernen Sie vor der Installation die Schutzfolie von allen Teilen
- Lassen Sie Kinder nicht in der Nähe des Montagebereichs spielen
- Achten Sie auf die Klemmgefahr
- Ziehen Sie die Schrauben nicht vollständig an, bevor Sie die entsprechenden Teile zusammen gebaut haben
- Alle Aufbauschnitte müssen genau befolgt werden
- Diagonalen und Auslotungen kontrollieren
- Befestigen Sie die Pergola erst nach dem Zusammenbau

Es dürfen keine Veränderungen am Produkt vorgenommen werden. Vom Benutzer abgeänderte Produkte, fallen nicht mehr unter die Garantie des Herstellers.

Der Standort sollte mit Bedacht gewählt sein. Es wird empfohlen, die Pergola nicht bei Regen, in der Hauptwindrichtung oder unter einem Baum aufzustellen. Die Pergola muss auf einem ausreichend stabilen und ebenen Fundament errichtet werden. Es wird empfohlen sie auf einer Betonplatte oder auf 25 x 25 cm großen Betonklötzen an jedem Pfosten zu errichten.

Wenn Sie Ihre Pergola in der Nähe Ihres Hauses oder eines Gebäudes montieren möchten, überprüfen Sie bitte das Vorhandensein von Regenrinnen für die Wasserableitung.

Falls diese Hinweise nicht oder nur teilweise befolgt werden, erlischt die Garantie des Verkäufers.

Wartung

Eine regelmäßige Pflege des Produkts ist nötig um eine Langlebigkeit des Produkts zu gewährleisten.

Empfehlungen:

- Waschen Sie die Pergola 1-2-mal im Jahr mit Süßwasser und einem Schwamm oder Tuch. Verwenden Sie keine aggressiven Reinigungs- oder Scheuermittel.
- Überprüfen Sie regelmäßig (min 1x im Jahr) ob die Schrauben fest angezogen sind.
- Ölen Sie die Befestigungen regelmäßig (mindesten 1x pro Jahr)
- Achten Sie darauf, dass nichts den Wasserabfluss in den Regenrinnen behindert (Blätter, Äste)
- Entfernen Sie Wasser, das sich an den Füßen der Pergola herum sammelt (heben Sie die Abdeckungen an)

Garantie

Die Garantie umfasst nicht:

- Normale Gebrauchsspuren des Produkts
- Verlust oder Bruch von Teilen beim Auspacken oder bei der Montage
- Mangel an vernünftiger Sorgfalt, Vernachlässigung, Vandalismus, Einwirkung fremder Gegenstände, Gewaltanwendung, Kontakt mit Schleifmittel, Ästhetik, Ausbau, Wiederaufbau oder Verlegung des Standorts.
- Höhere Gewalt: Hagel, starke Winde, Stürme, Schnee, Überschwemmungen, Blitzschlag...
- Veränderung des Produkts durch den Benutzer.

Die Garantie umfasst nur den Ersatz des Ersatzteils oder des gelieferten Produktes, unter Ausschluss jeglicher Kosten und Entschädigungen jeglicher Art.

Die Garantie muss bei der Verkaufsstelle (Geschäft oder Internetseite) beantragt werden, bei der Sie Ihr Produkt gekauft haben.



Teileliste pro Karton









Bevor Sie mit dem Aufbau beginnen, bitten wir Sie alle aufgeführten Bauteile auf Vollständigkeit zu prüfen. Zudem bitten wir Sie nachzuschauen, dass keine Schäden an den Teilen vorhanden sind. Fehlende oder beschädigte Teile müssen binnen 10 Werktagen beim Hersteller reklamiert werden nach Anlieferung der Ware.



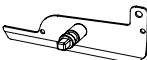
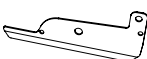







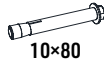



Sie können hierzu gerne unseren Kundenservice kontaktieren.

Entsorgen Sie die Verpackung nicht, ohne sicherzustellen, dass das Produkt richtig funktioniert.



KARTON 1/5 (Pfosten und lose Teile)



Referenz	Teile	Menge
A0		4
A0-1		2

Referenz	Teile	Menge
I0		6
J0		6
K0		2
L0		36
LO-1		38
EO-1		2
MO		74
Q0		24
RO		24
SO		76

Referenz	Teile	Menge
T0	 10x80	24
U0	 lock nut	112
U0-3	 M14	2
W0	  PH2	152
W0-1	  5x19 5mm	6
X0	  6x40 4mm	74
X0-1	  6x35 4mm	24
X0-3	  6x16 4mm	4
V0		38

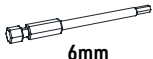
KARTON 1/5 (Pfosten und lose Teile)



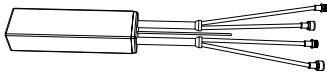
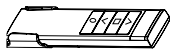
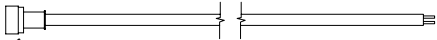
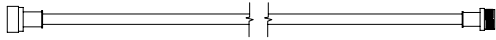
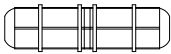
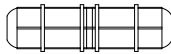

Referenz	Teile	Menge
Z0-1	 4mm	1
Z0-2	 4mm	1
Z0-3	 6mm	1
Z0-4	 6mm	1

Referenz	Teile	Menge
Z0-5	 10mm	1
Z0-6	 PH2	1
Z0-7		1

Elektrische Produkte

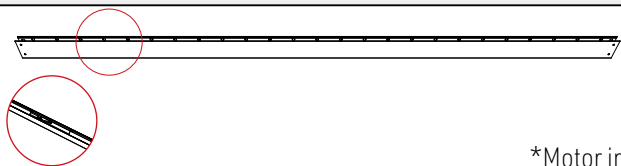
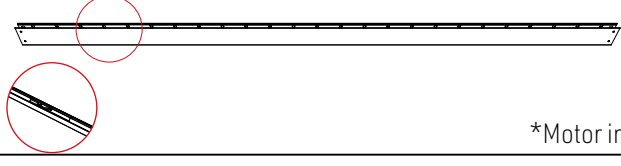
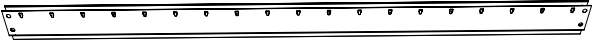
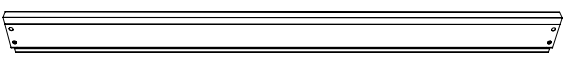
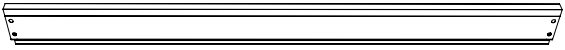
Referenz	Teile	Menge
E-C	 Controller	1
E-R	 Fernbedienung	1
E-P	 Netzkabel(M15)	1
E-P1	 Motoranschlusskabel (M12)	1
E-W2	 Wasserdichtes Gelenk(2)	1
E-W3	 Wasserdichtes Gelenk(3)	1

KARTON 2/5 (Balken)

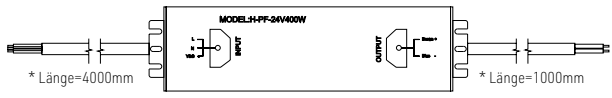
Referenz	Teile	Menge
B1	 <p>*Motor innen</p>	1
B2	 <p>*Motor innen</p>	1
BO-1		2
CO		1
CO-1		1
DO		4
FO		2
EO		1
E-T	 <p>Transformator</p>	1



Verbindungsstange (FO) und Bürste im Inneren

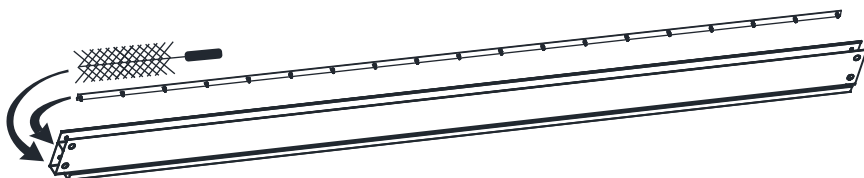

KARTON 3/5(Lamellen)

Referenz	Teile	Menge
GO		13

KARTON 4/5(Lamellen)

Referenz	Teile	Menge
GO		13

KARTON 5/5(Lamellen)

Referenz	Teile	Menge
GO		12

Montageanleitung

Schritt 1: Rahmen & Motor

Schritt 2: Lamellen

Schritt 3: Verbindungen

Schritt 1: Rahmen & Motor

Hinweise:

1. Bitte setzen Sie den Transformator in den Seitenbalken ein, der nahe am Motor ist.
2. Führen Sie das Eingangskabel des Transformators durch den Pfosten und ziehen Sie dann das Kabel aus der Kerbe an der Basis des Pfostens, um die Stromversorgung anzuschließen.
3. Bitte schließen Sie die Verkabelung gemäß dem untenstehenden Diagramm an.

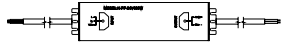
E-T	 Transformator	1
-----	-----------------------------------------------------------------------------------------------------------	---

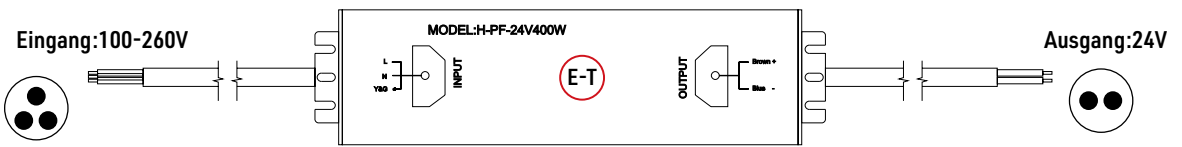

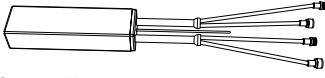
E-C	 Controller	1
-----	--------------------------------------------------------------------------------------------------------	---

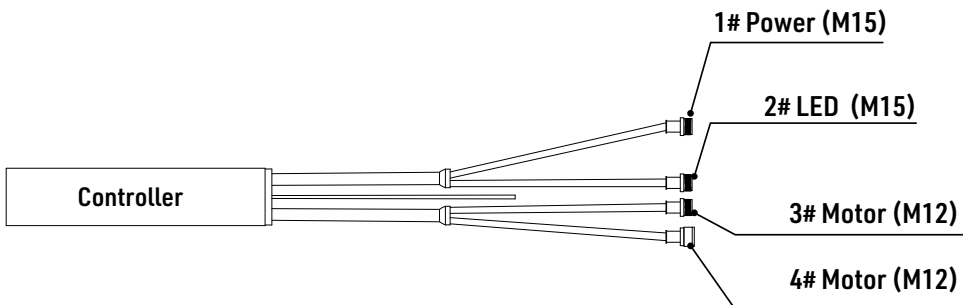

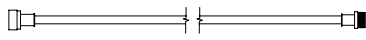
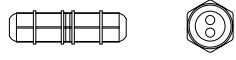
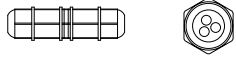
E-P		1
E-P1		1
E-W2		1
E-W3		1

Schritt 1: Rahmen & Motor

Motor, Controller und Transformator
Platzierung in der Pergola

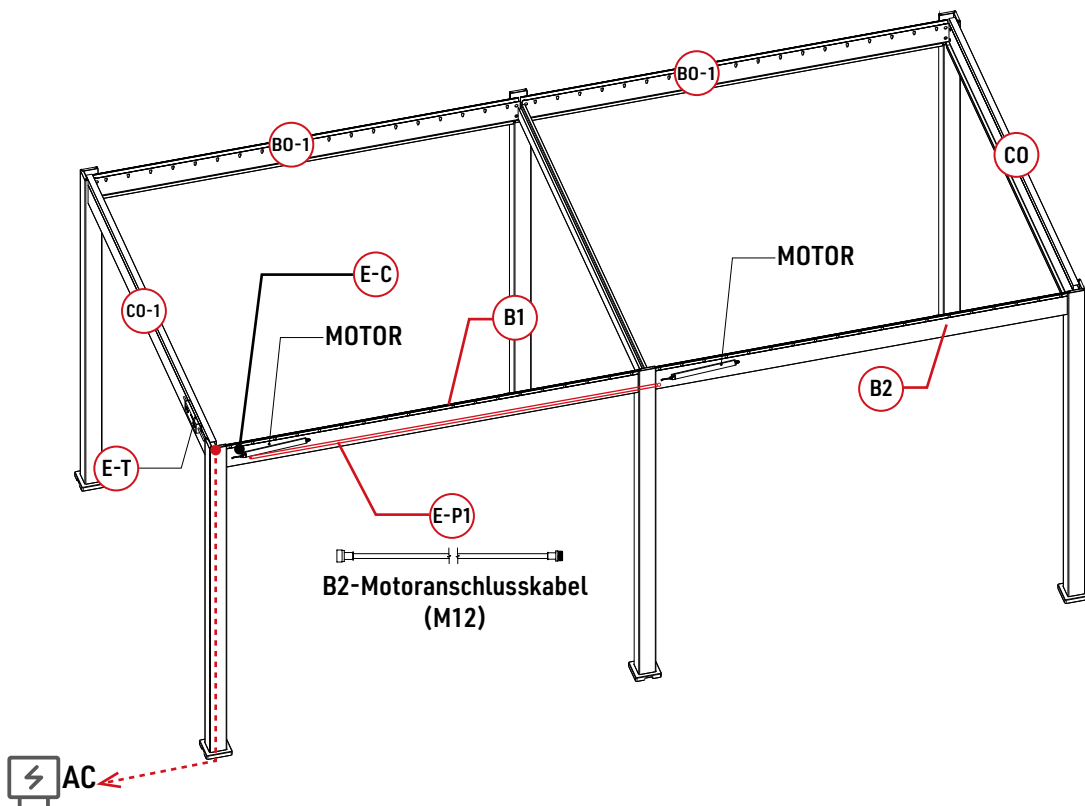



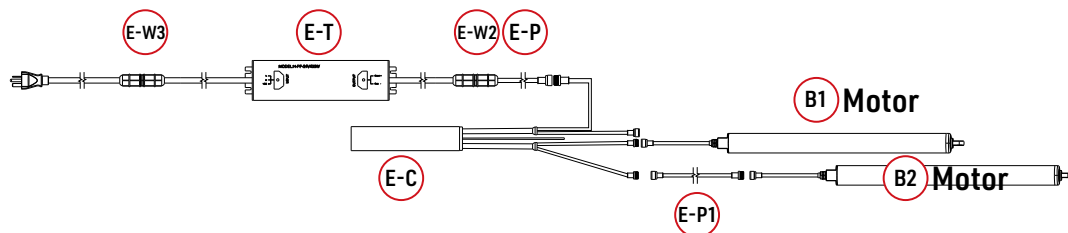

Schaltplan





Schritt 1: Rahmen & Motor 1-1

Teile

A0		4		
I0		4	X0-1	 6x35 4mm 16
J0		4		

Werkzeuge

Z0-1	 4mm	1
Z0-2	 4mm	1



Diagramm zur Fertigstellung.

1.



2.

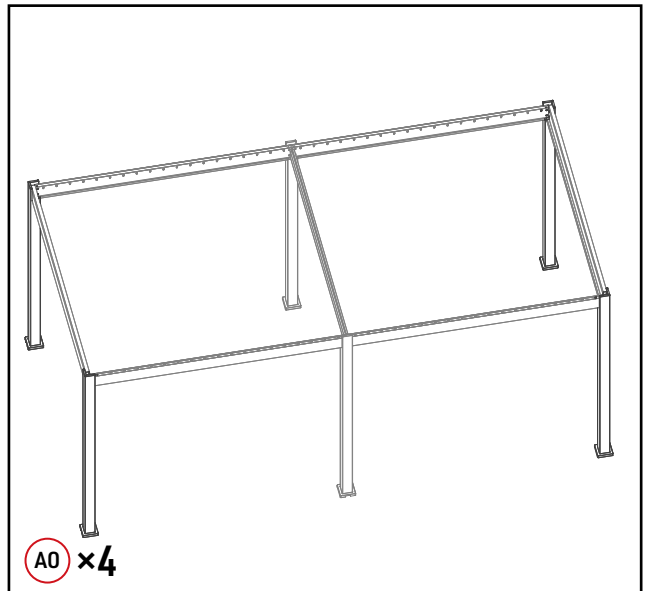
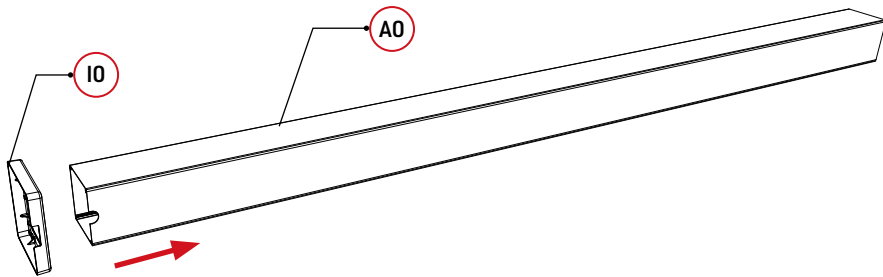
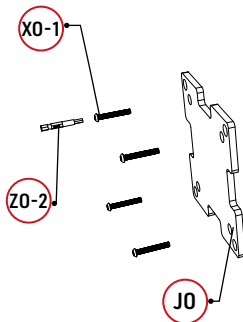



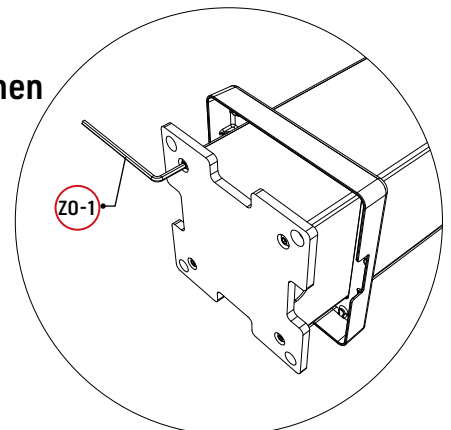

3. Spannen





Schritt 1: Rahmen & Motor 1-1

Teile

A0-1		2			
I0		2	X0-1		8
J0		2			

Werkzeuge

Z0-1		1
Z0-2		1



(A0-1) x2



Diagramm zur Fertigstellung.

1.



2.

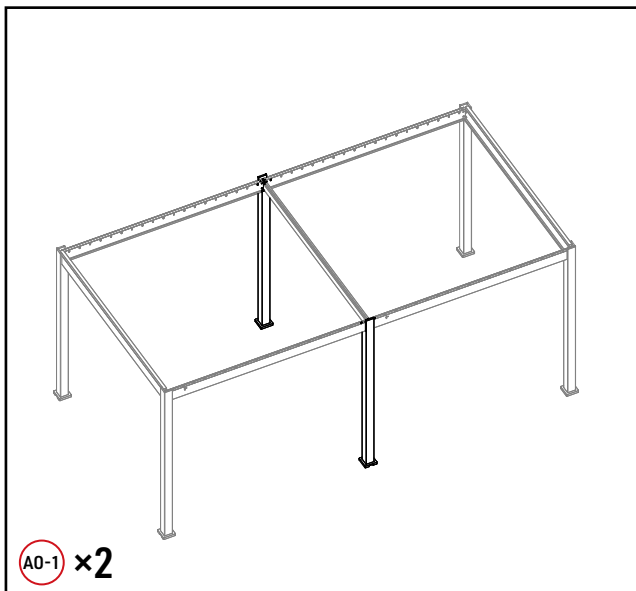
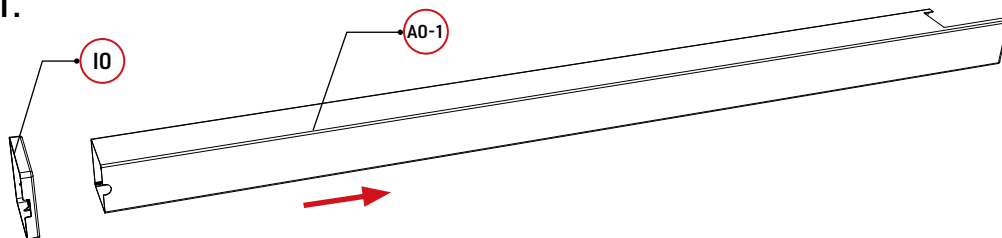
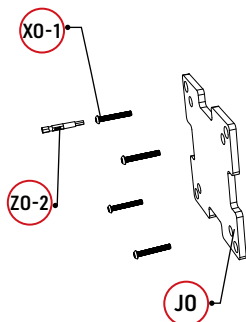

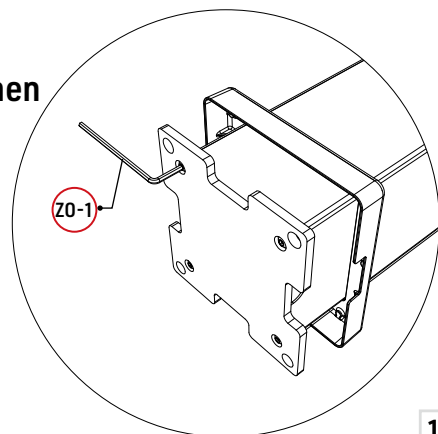

3. Spannen



Schritt 1: Rahmen & Motor 1-2

Teile

B1		1
B2		1
BO-1		2
DO		4

Entfernen Sie die Endkappen vom Balken.

1.

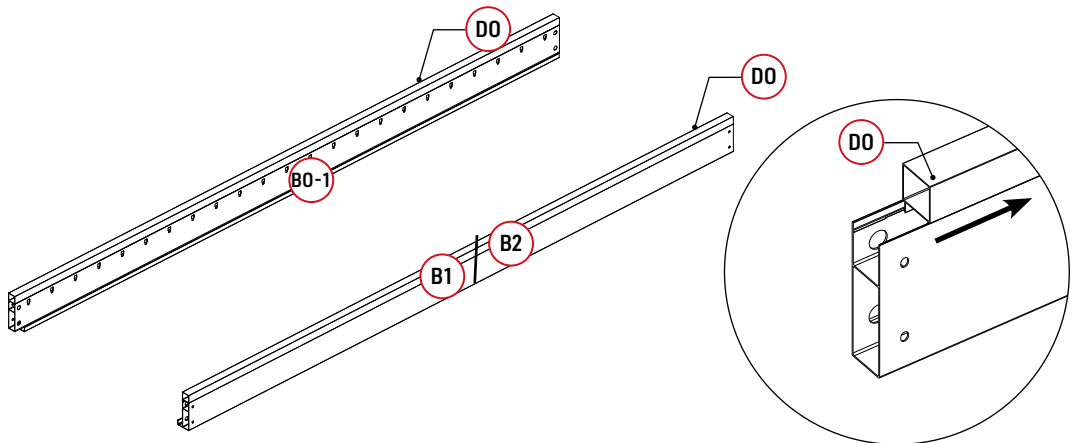

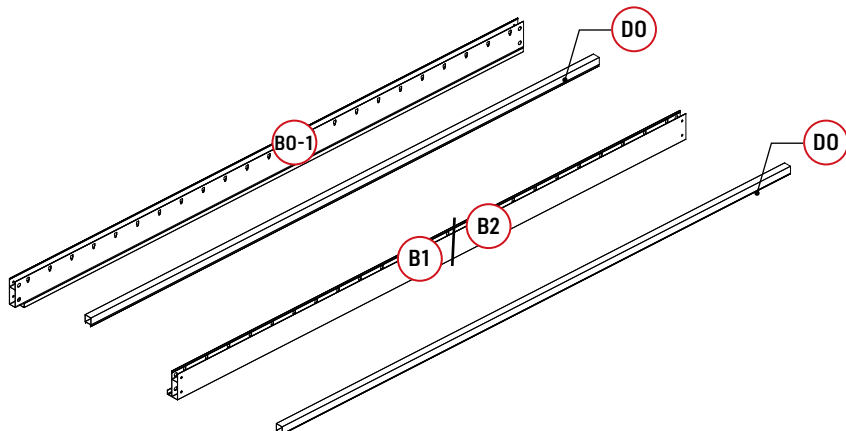

2.



Schritt 1: Rahmen & Motor 1-3

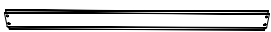

Teile

CO		1
CO-1		1

E-T		1
-----	-----------------------------------------------------------------------------------	---

Q0		8
----	-----------------------------------------------------------------------------------	---

Werkzeuge

Z0-3		1
Z0-4		1

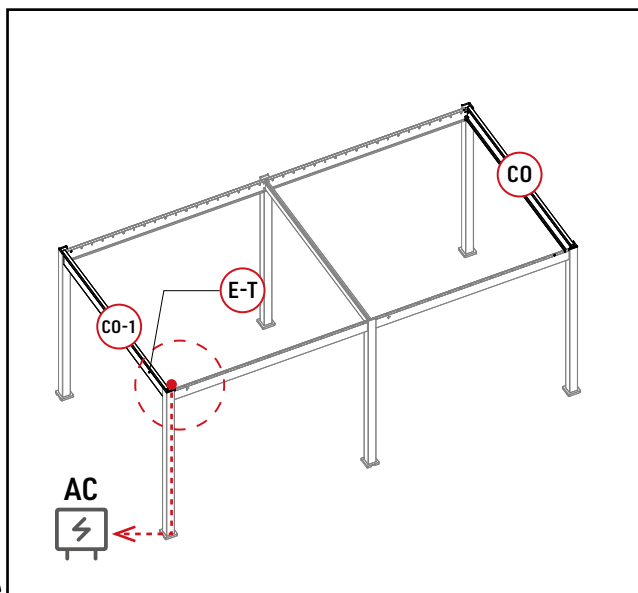

Balken mit Pfosten verbinden.

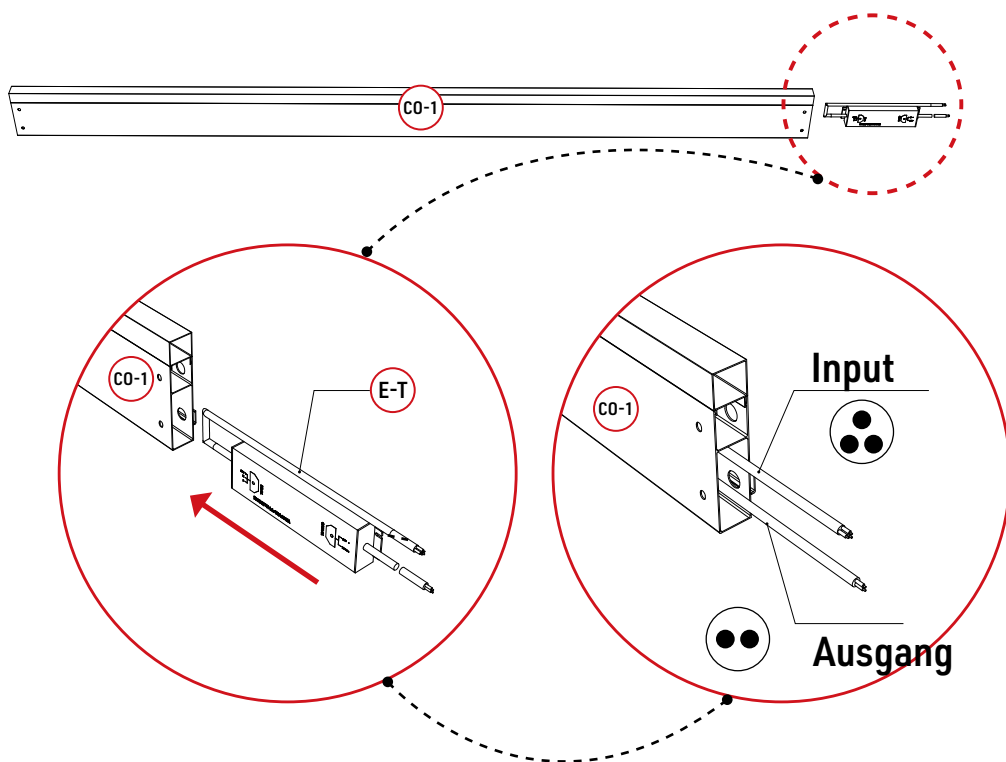

Schritt 1: Rahmen & Motor 1-3

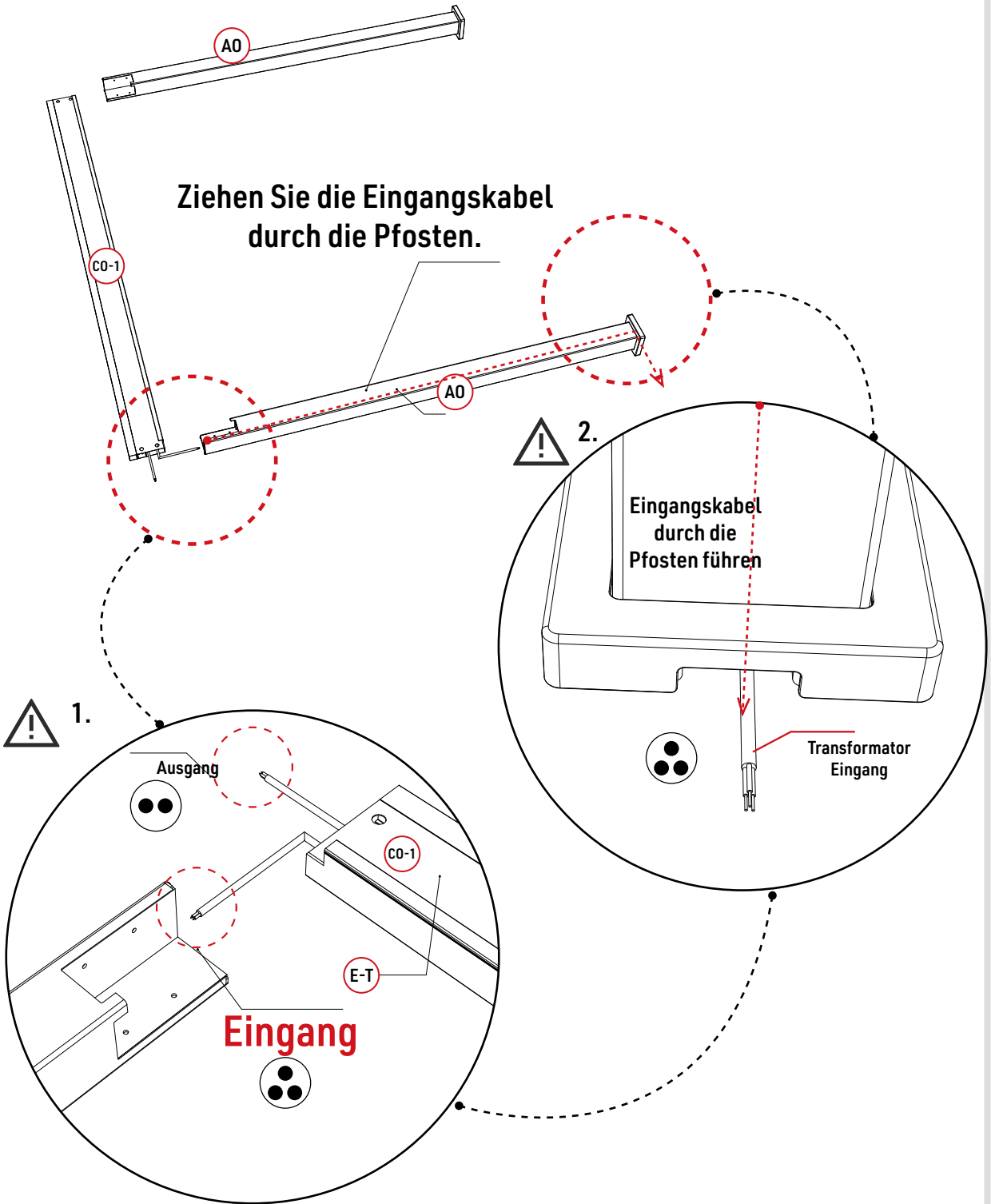

Schritt 1: Rahmen & Motor 1-3

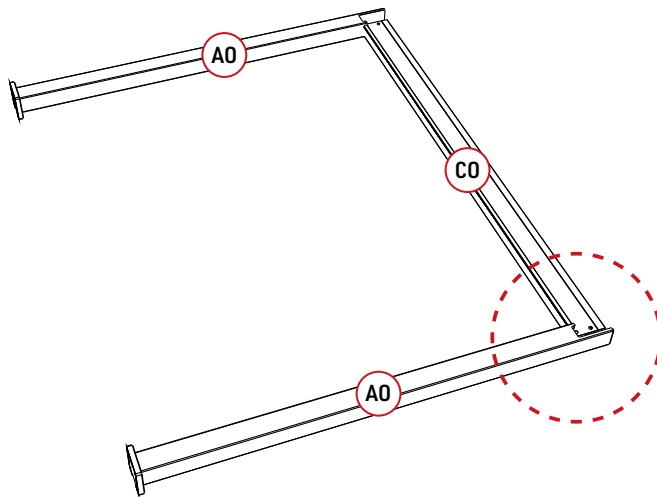
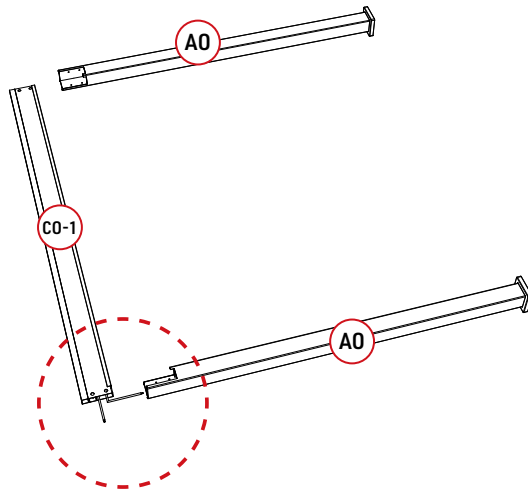

1.

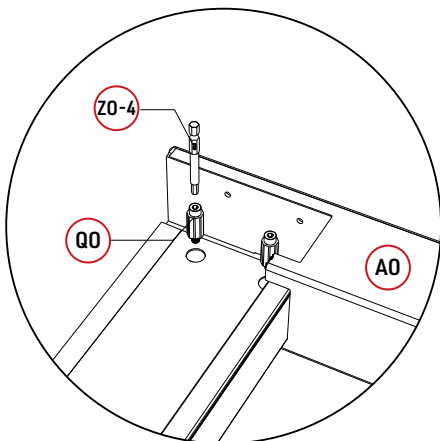



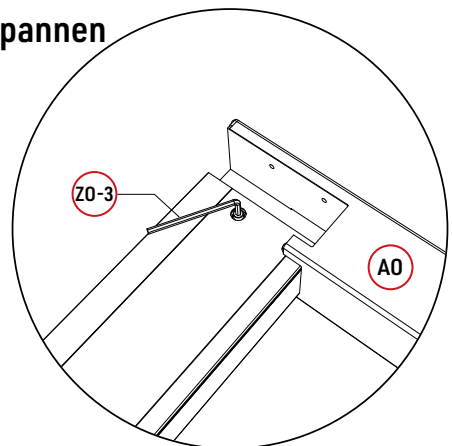

2. Spannen



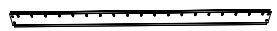

Schritt 1: Rahmen & Motor 1-4

Teile

B1		1
B2		1
BO-1		2
Q0	 6mm	16

Werkzeuge

Z0-3	 6mm	1
Z0-4	 6mm	1

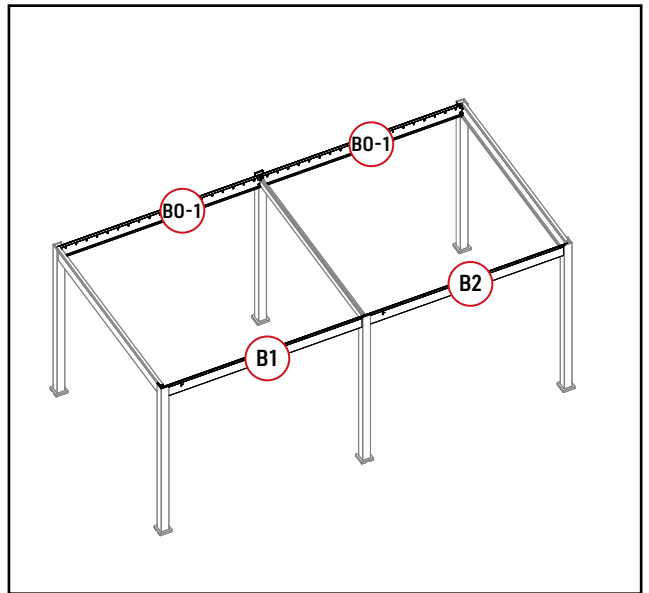

Balken mit Pfosten verbinden.

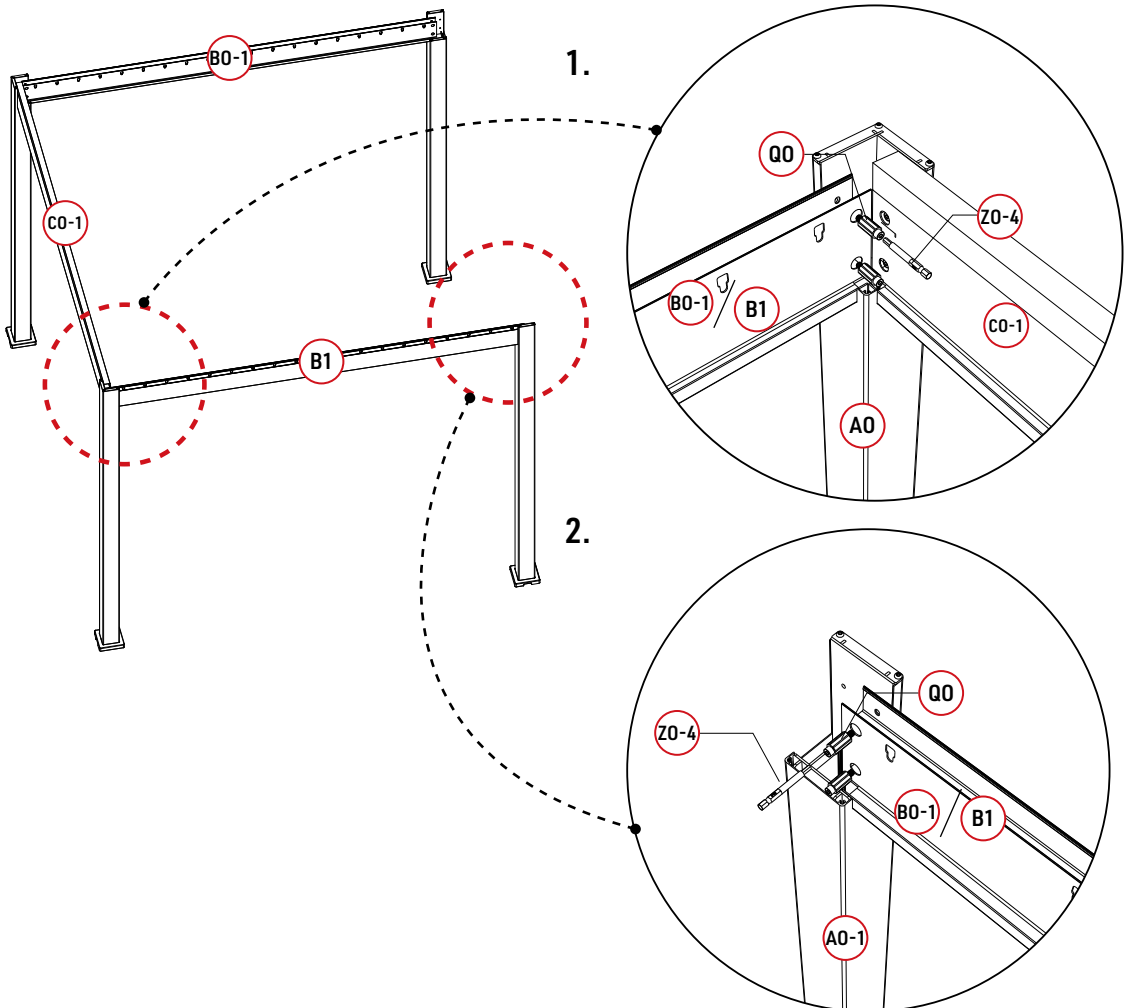

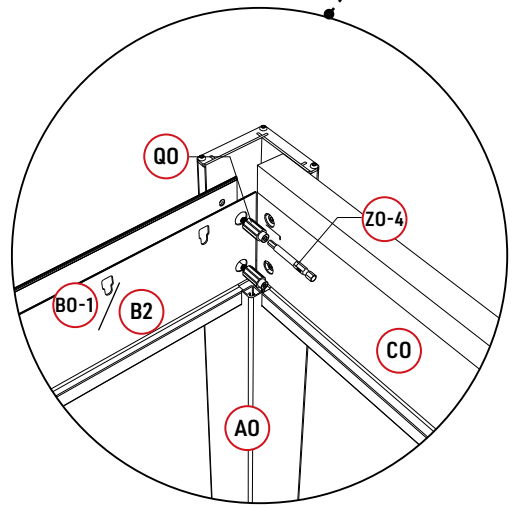
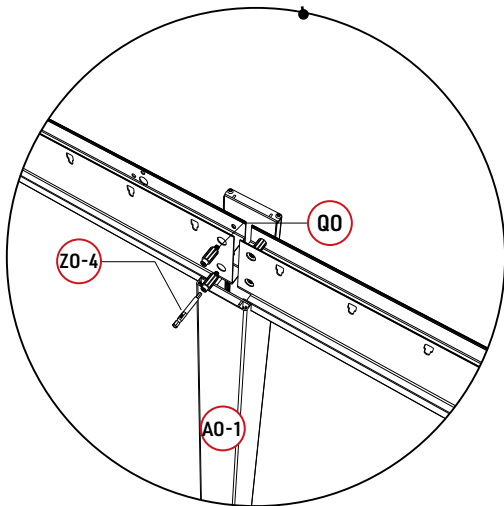
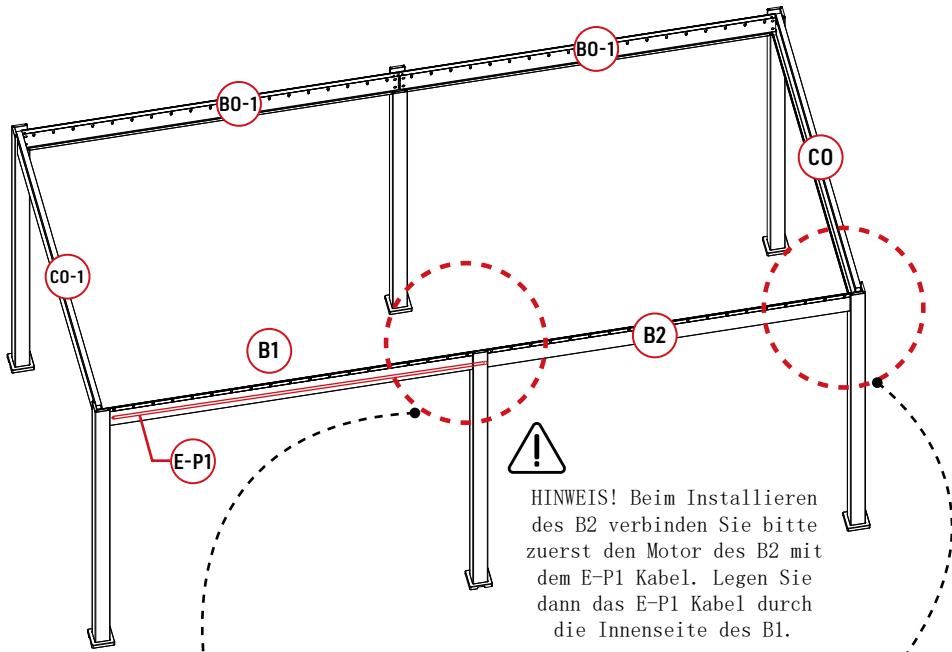

Spannen

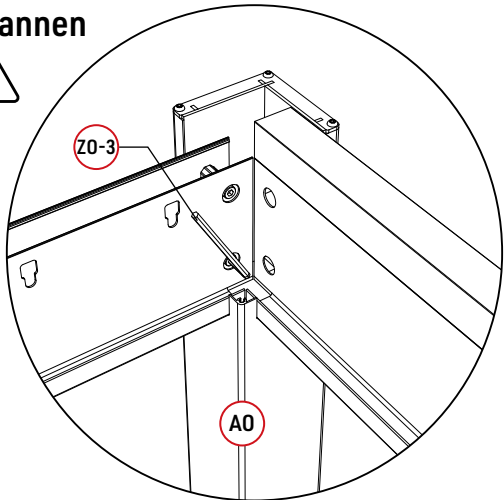

Spannen

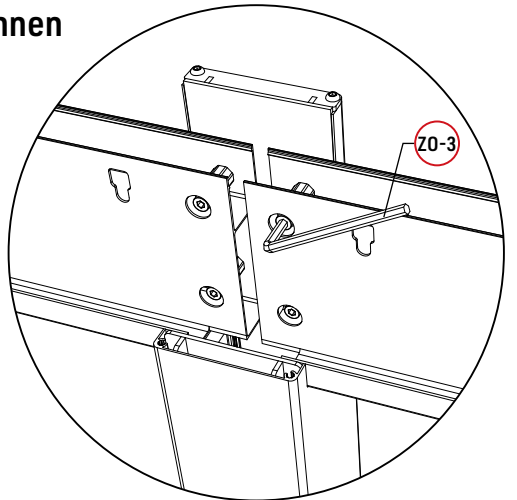

Schritt 1: Rahmen & Motor 1-5

Teile

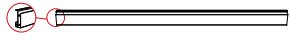
EO		1
----	-----------------------------------------------------------------------------------	---

EO-1		2
------	-----------------------------------------------------------------------------------	---

WO-1		6
------	-----------------------------------------------------------------------------------	---

XO-3		4
------	-----------------------------------------------------------------------------------	---

Werkzeuge

ZO-1		1
------	-----------------------------------------------------------------------------------	---

ZO-2		1
------	-----------------------------------------------------------------------------------	---

ZO-7		1
------	-----------------------------------------------------------------------------------	---

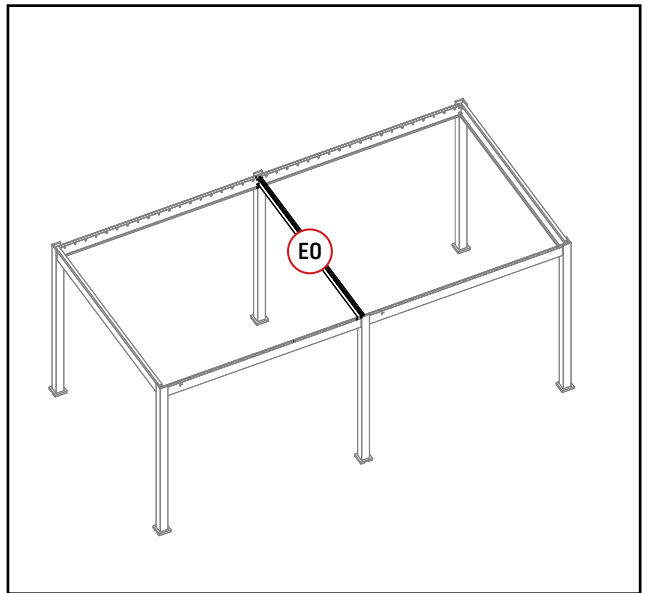

Balken mit Pfosten verbinden.

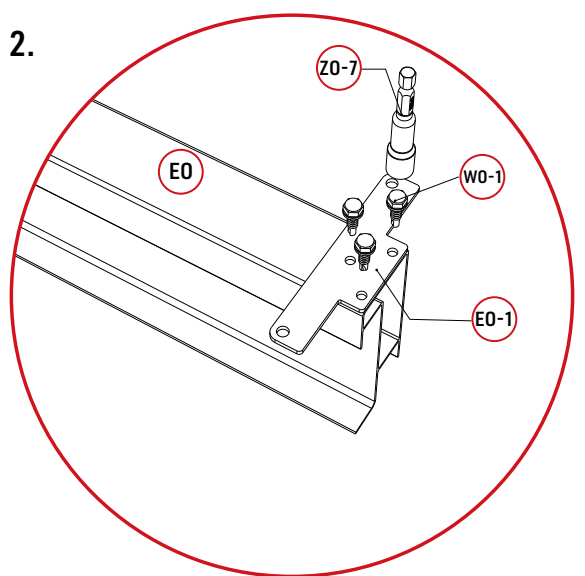
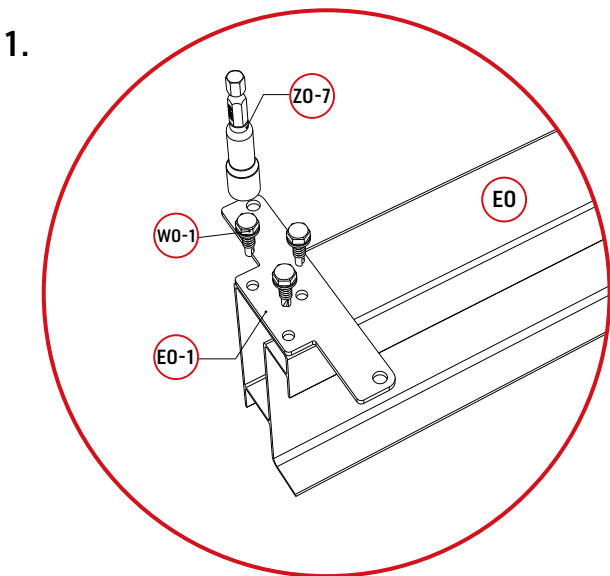
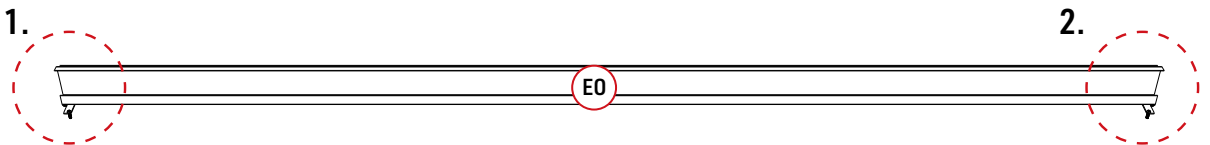

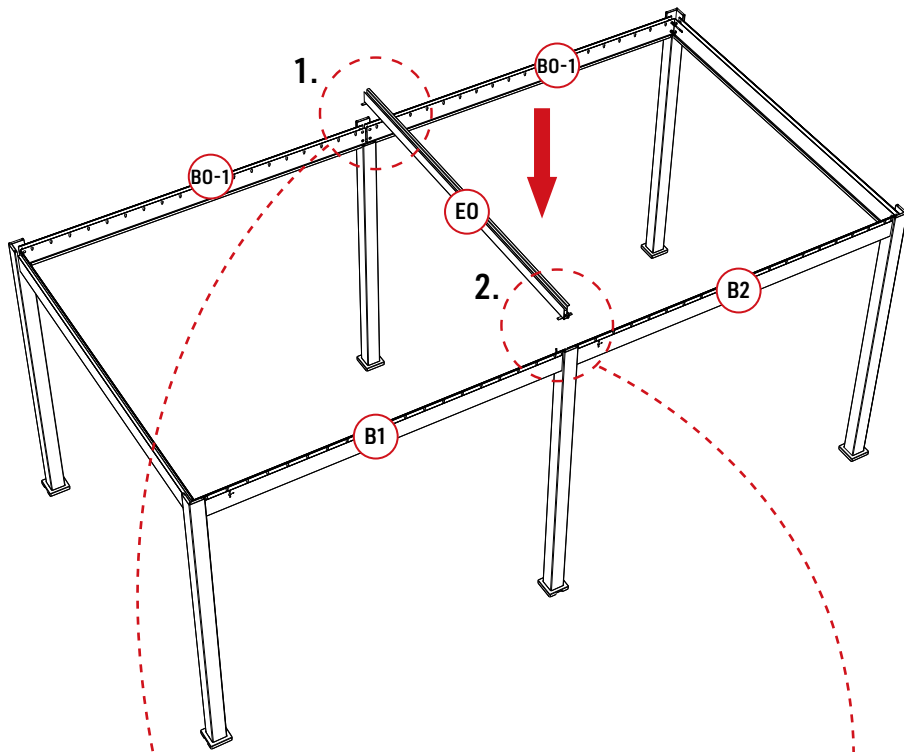

1. !

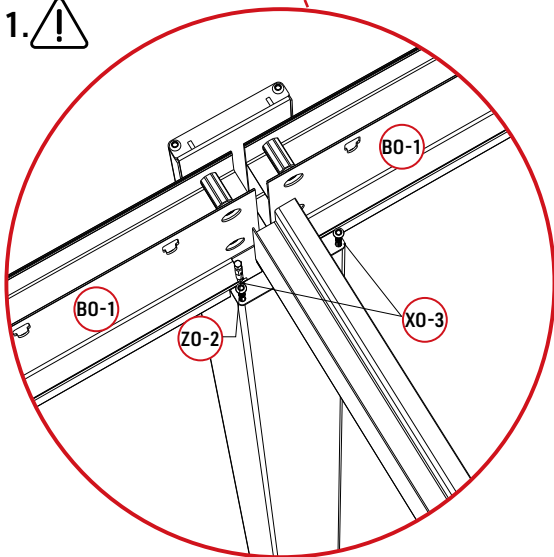

2. !

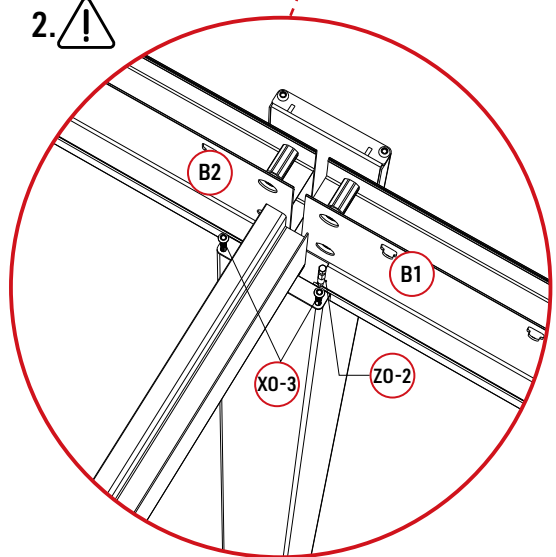



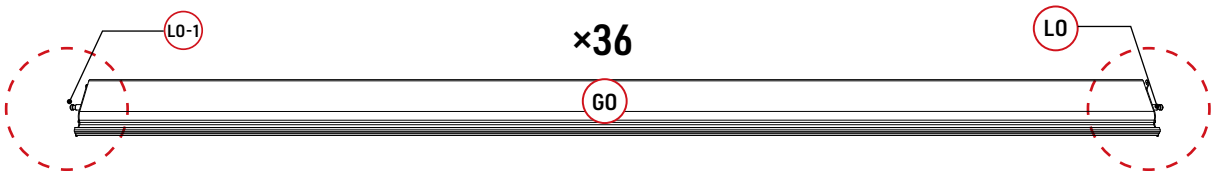
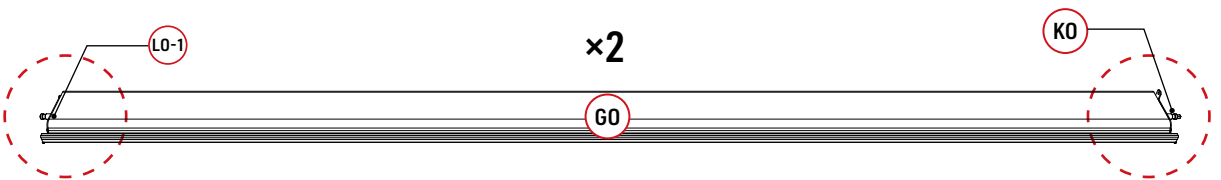
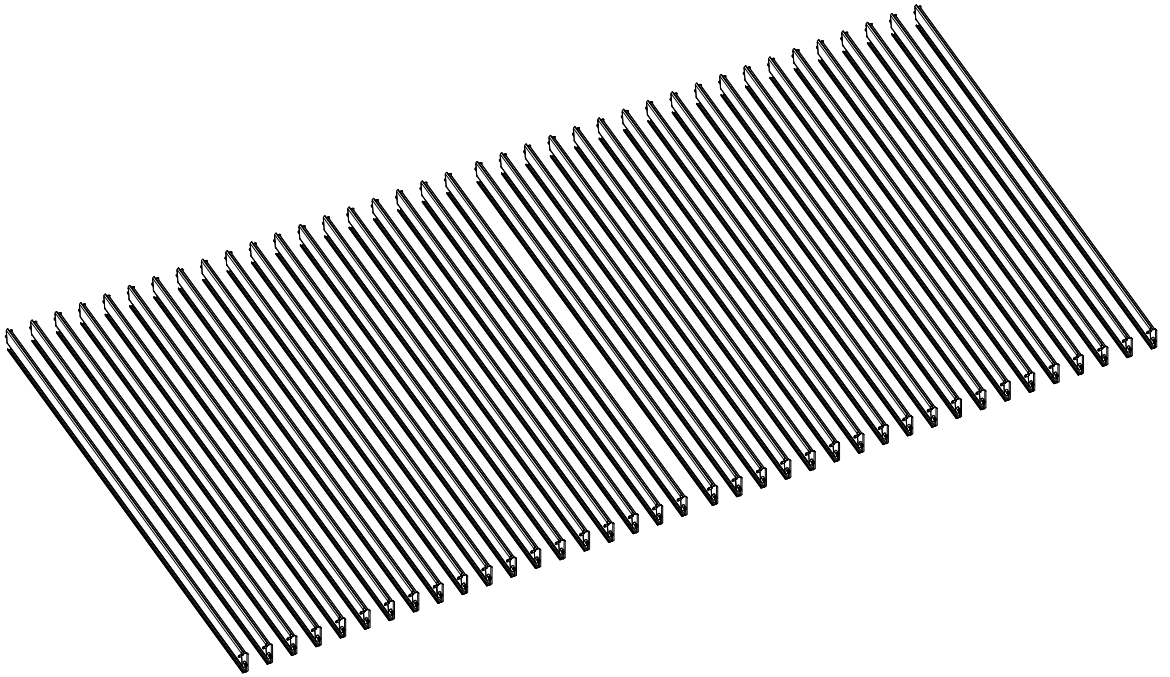

Schritt 2: Lamellen





Schritt 2: Lamellen

2-1

Teile

LO		36	XO		74
LO-1		38	UO		74
MO		74			

Werkzeuge

ZO-1		1
ZO-2		1

Lamellen-Dichtungsplatte

LO ×36

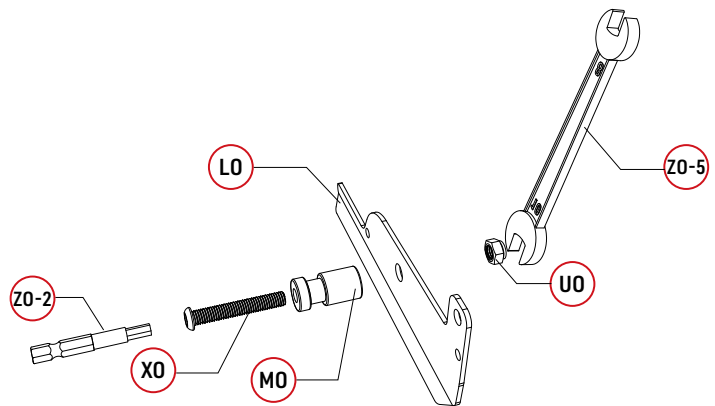
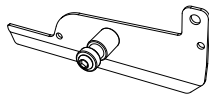

Lamellen-Dichtungsplatte



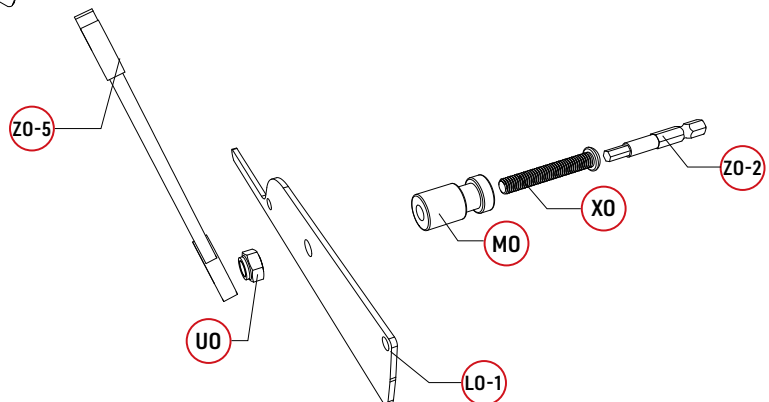
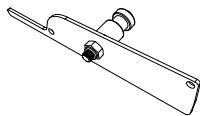

LO ×38





Schritt 2: Lamellen

2-2

Teile

GO		38
KO		2
LO		36
LO-1		38
WO		152

Werkzeuge

ZO-1		1
ZO-2		1
ZO-6		1



GO ×38

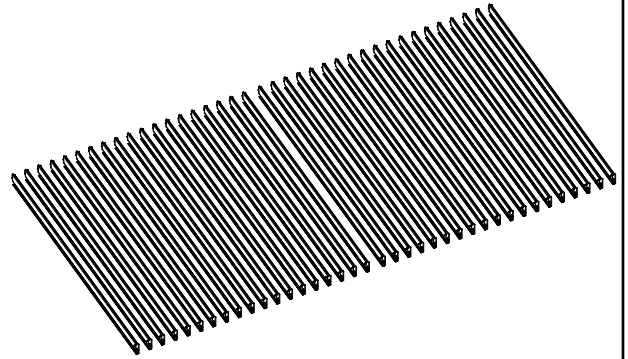

Anschluss der Lamellen.

Diagramm zur Fertigstellung

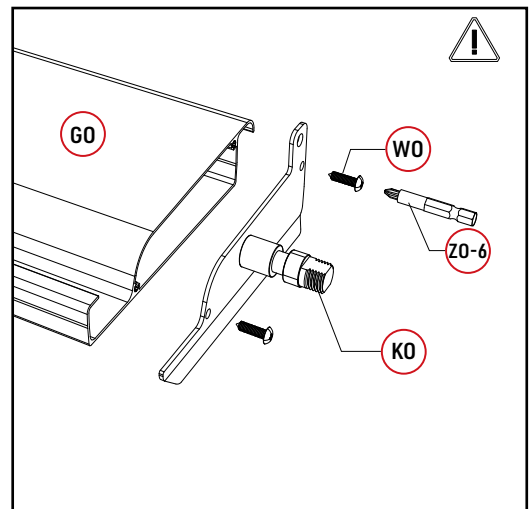
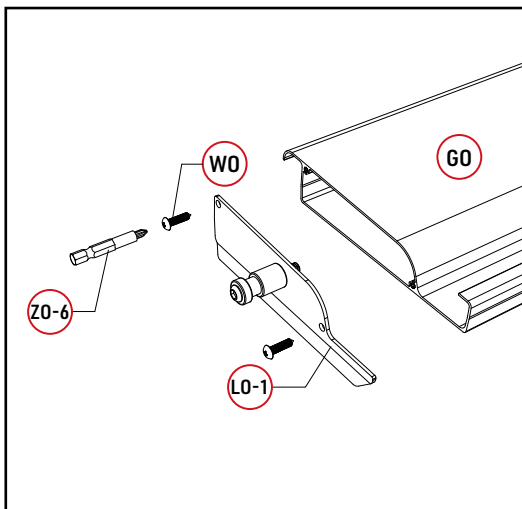
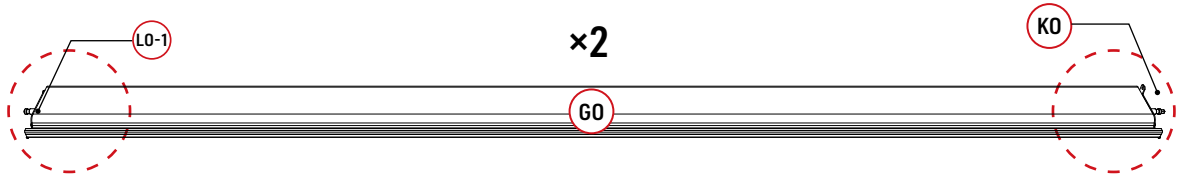

Anschluss der Lamellen.

Diagramm zur Fertigstellung

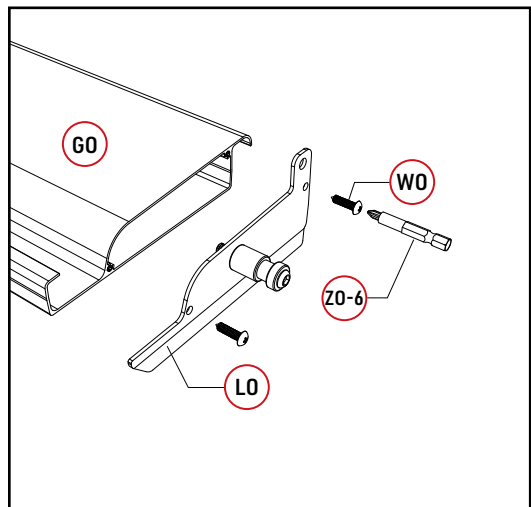
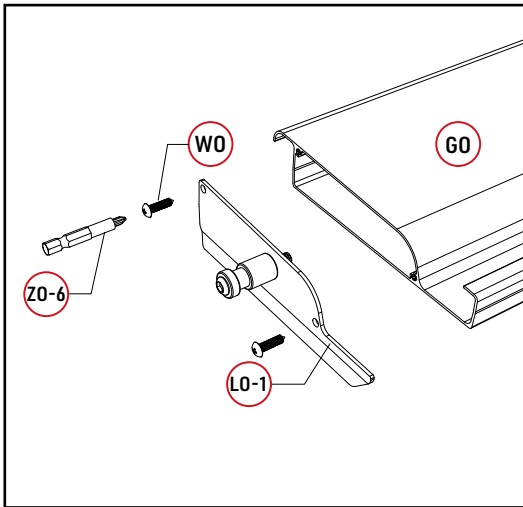
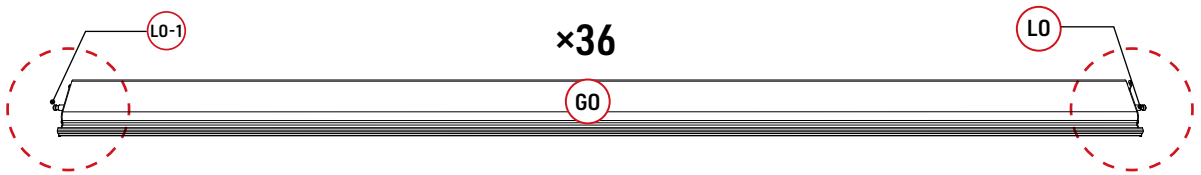

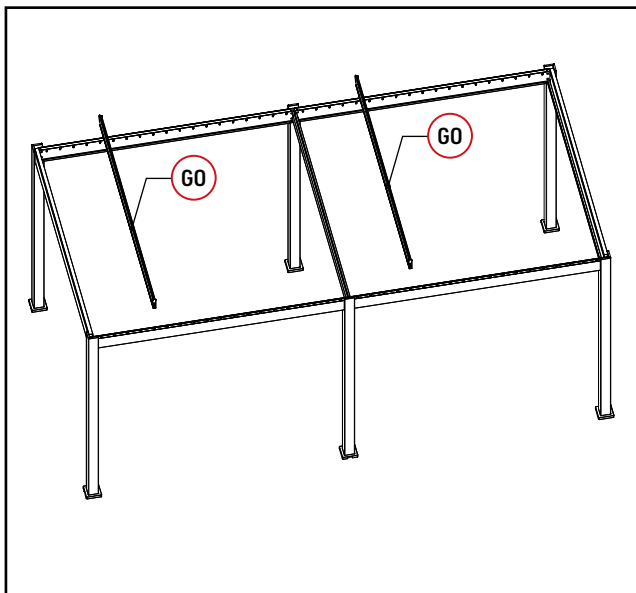

Installieren Sie die ersten beiden Lamellen auf den Balken.

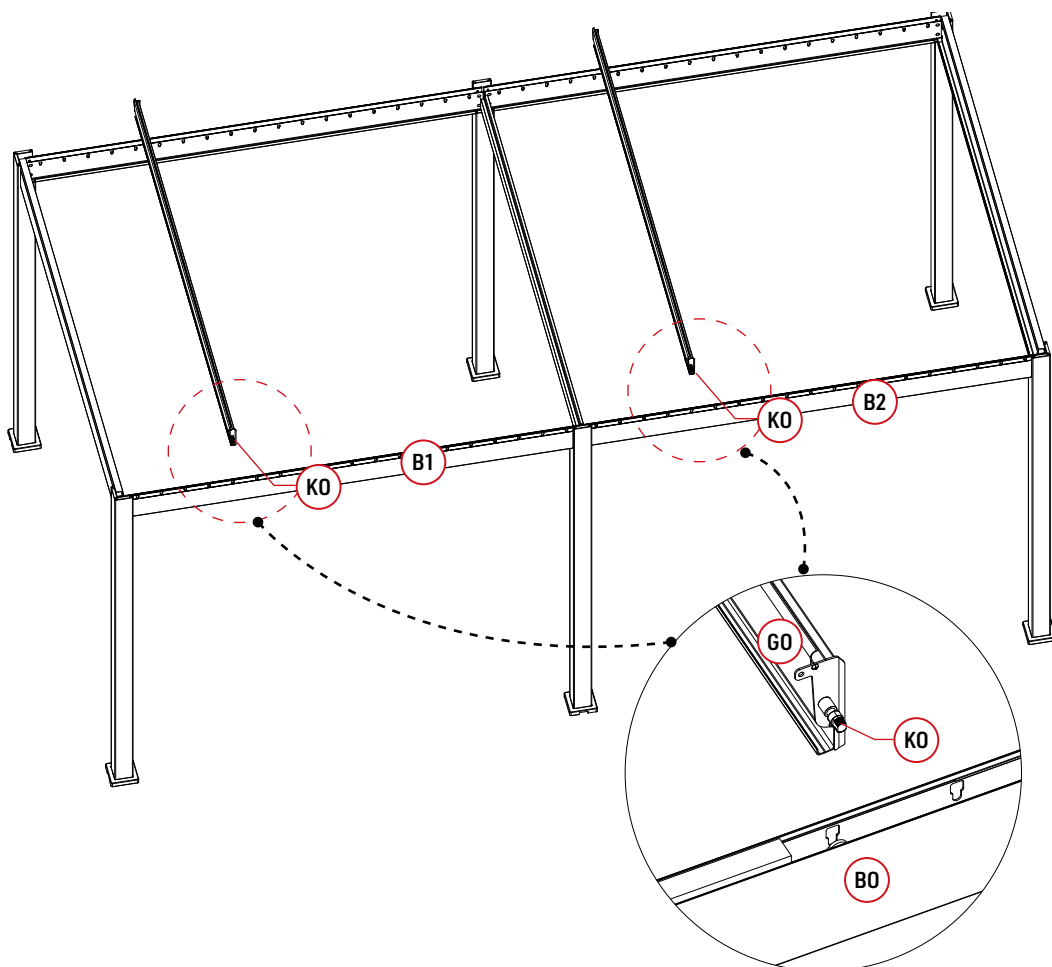

1

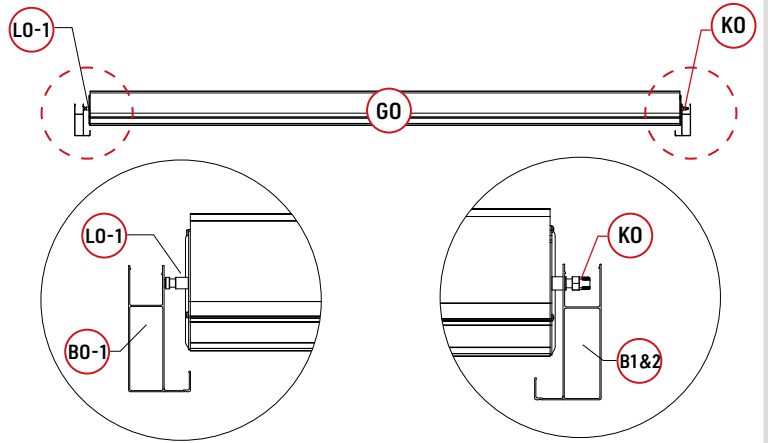
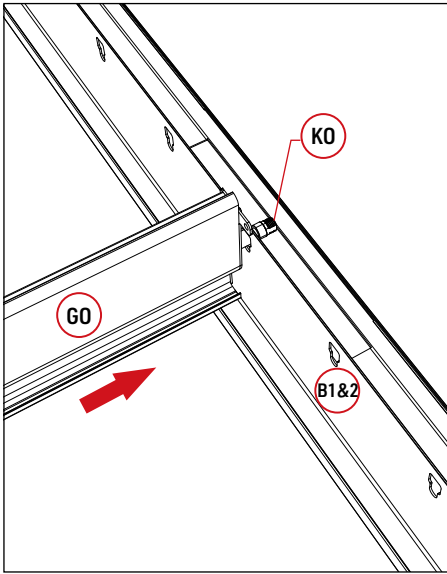

2

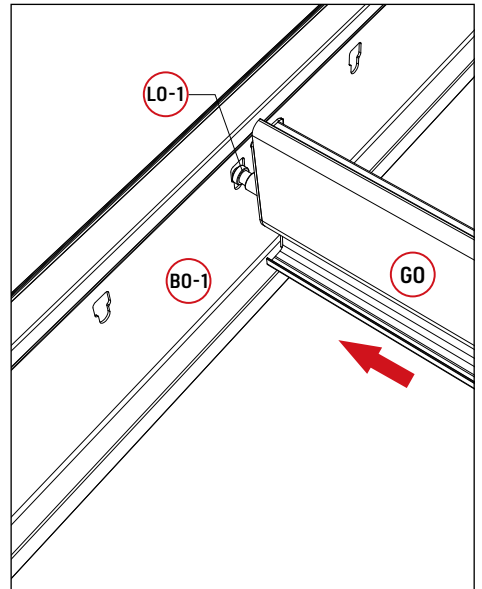
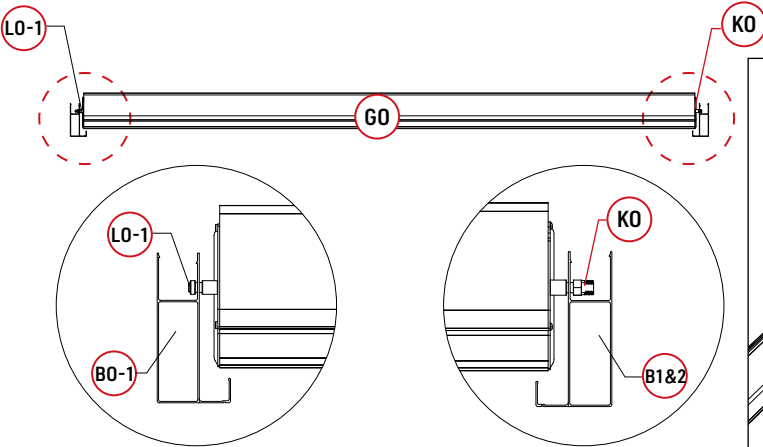

Schritt 3: Verbindungen

3-2

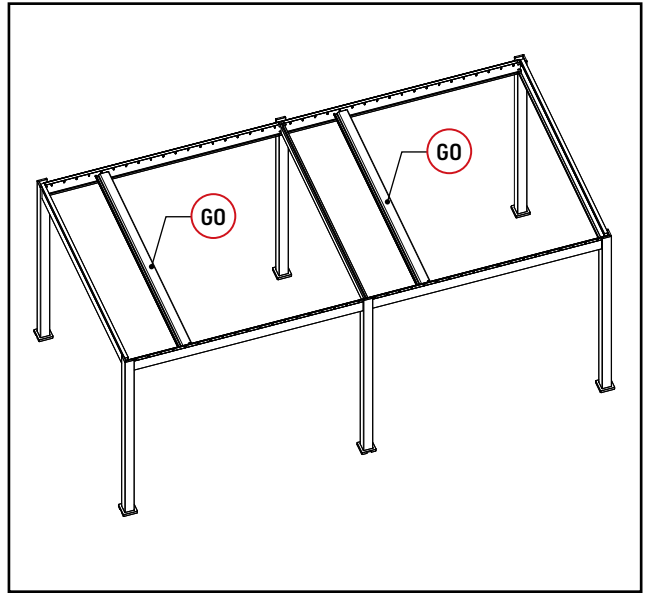

Machen Sie die Lamellen flach und verbinden Sie dann den Motorkipphebel mit der Spindel.

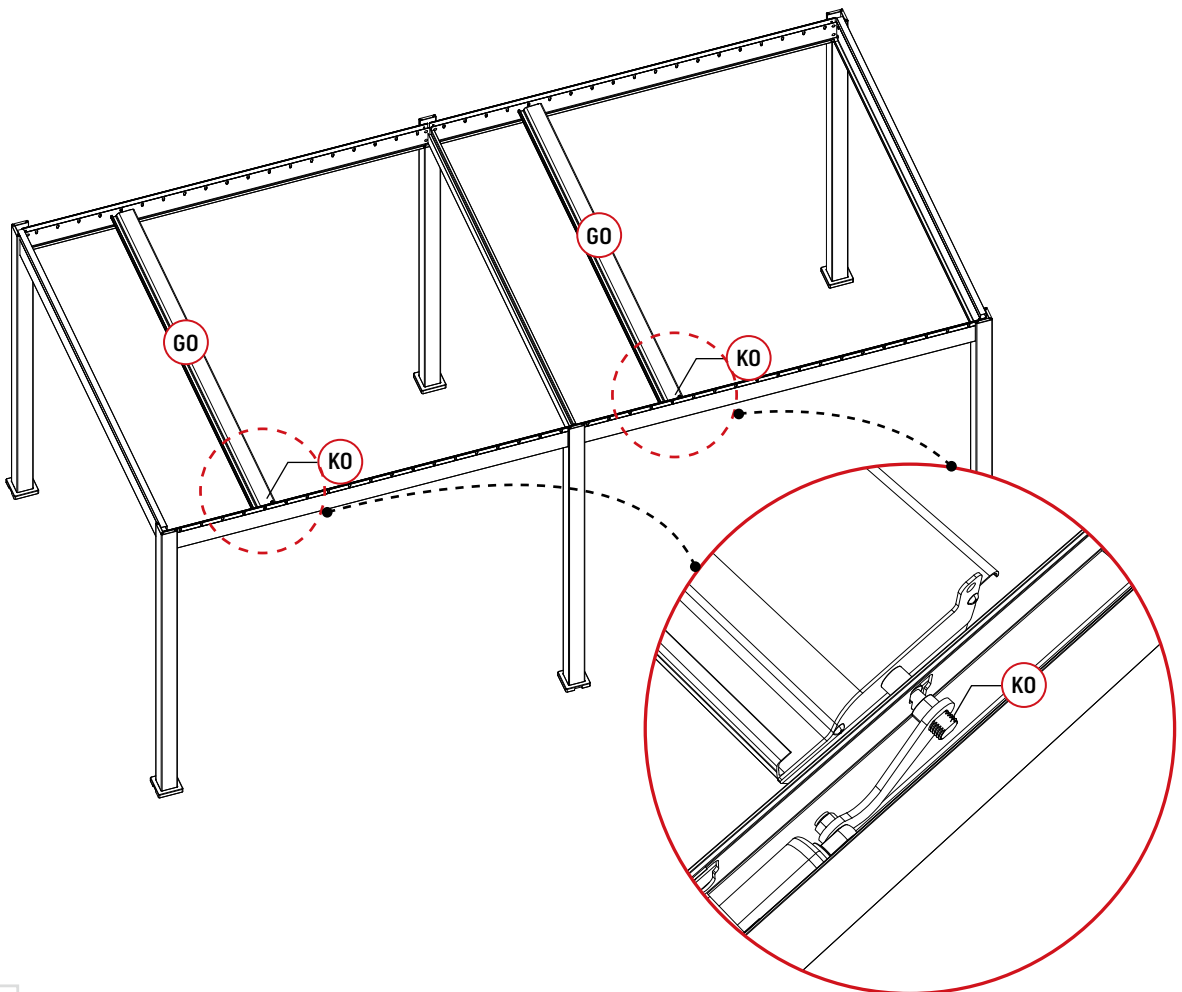

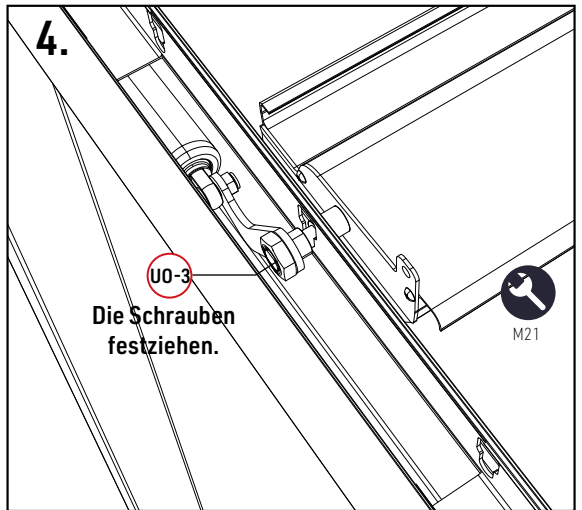
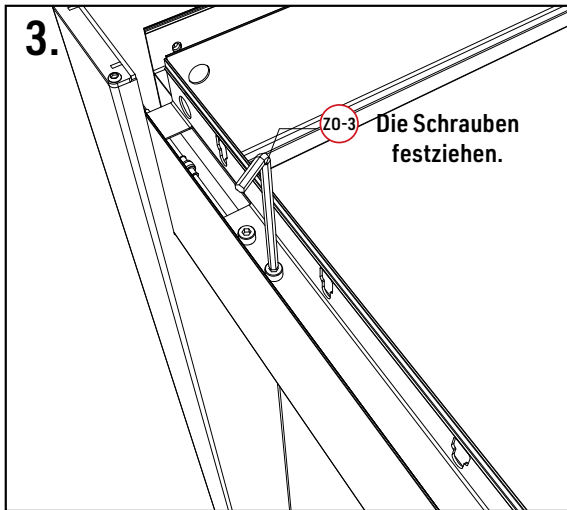
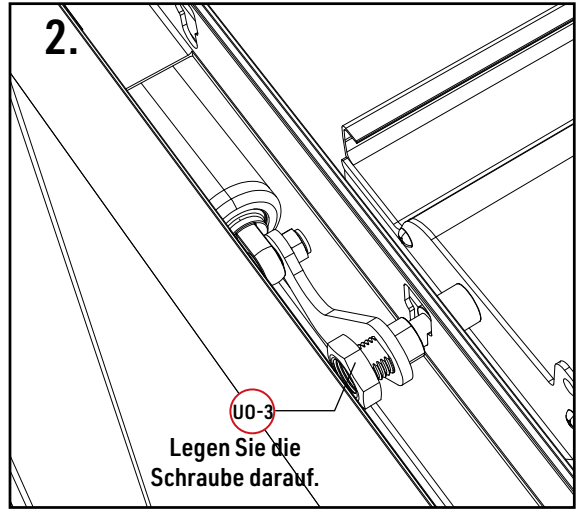
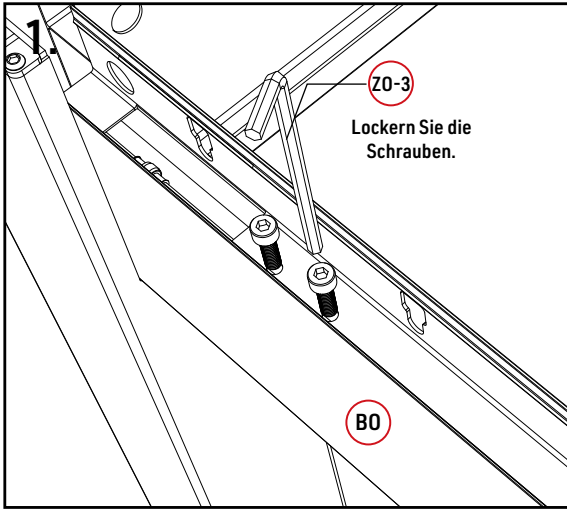

Schritt 3: Verbindungen

3-3

E-R		1
-----	-----------------------------------------------------------------------------------	---

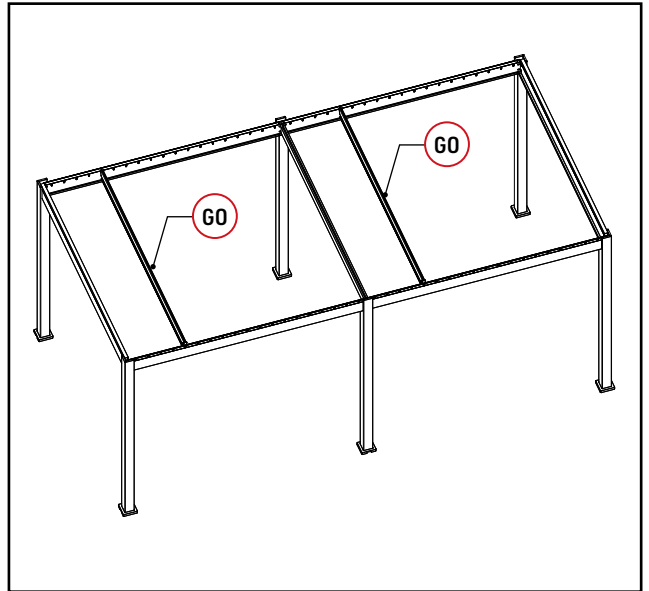

Motoranschluss



1. Drücken Sie die UP-Taste auf der Fernbedienung und halten Sie diese Taste 3-5 Sekunden lang gedrückt, bis die Anzeige durchgehend leuchtet.
2. Stecken Sie den Stromstecker ein und drücken Sie dabei die UP-Taste. Wenn eine leichte Vibration am Hauptlamellen erscheint, bedeutet dies, dass die Fernbedienung und der Motor gekoppelt sind.

Schritt 1.

Drücken und halten Sie 3 Sekunden lang.

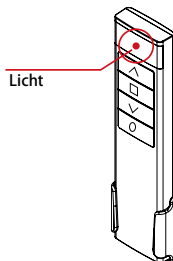
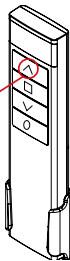

Schritt 2.

Stecken Sie den Stromstecker ein.

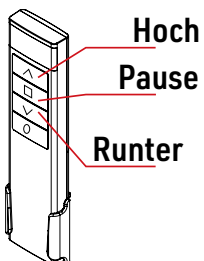
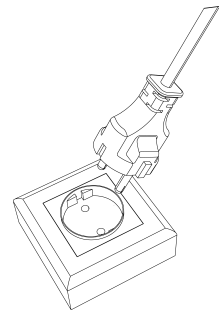

1. Überprüfen Sie, ob der Motor einwandfrei funktioniert. Wenn nicht, überprüfen Sie bitte zuerst, ob die Verkabelung in den vorherigen Schritten korrekt ist.
2. Wenn der Motor gut funktioniert, drehen Sie bitte die Hauptlamelle um 90 Grad und installieren Sie dann die restlichen Lamellen.

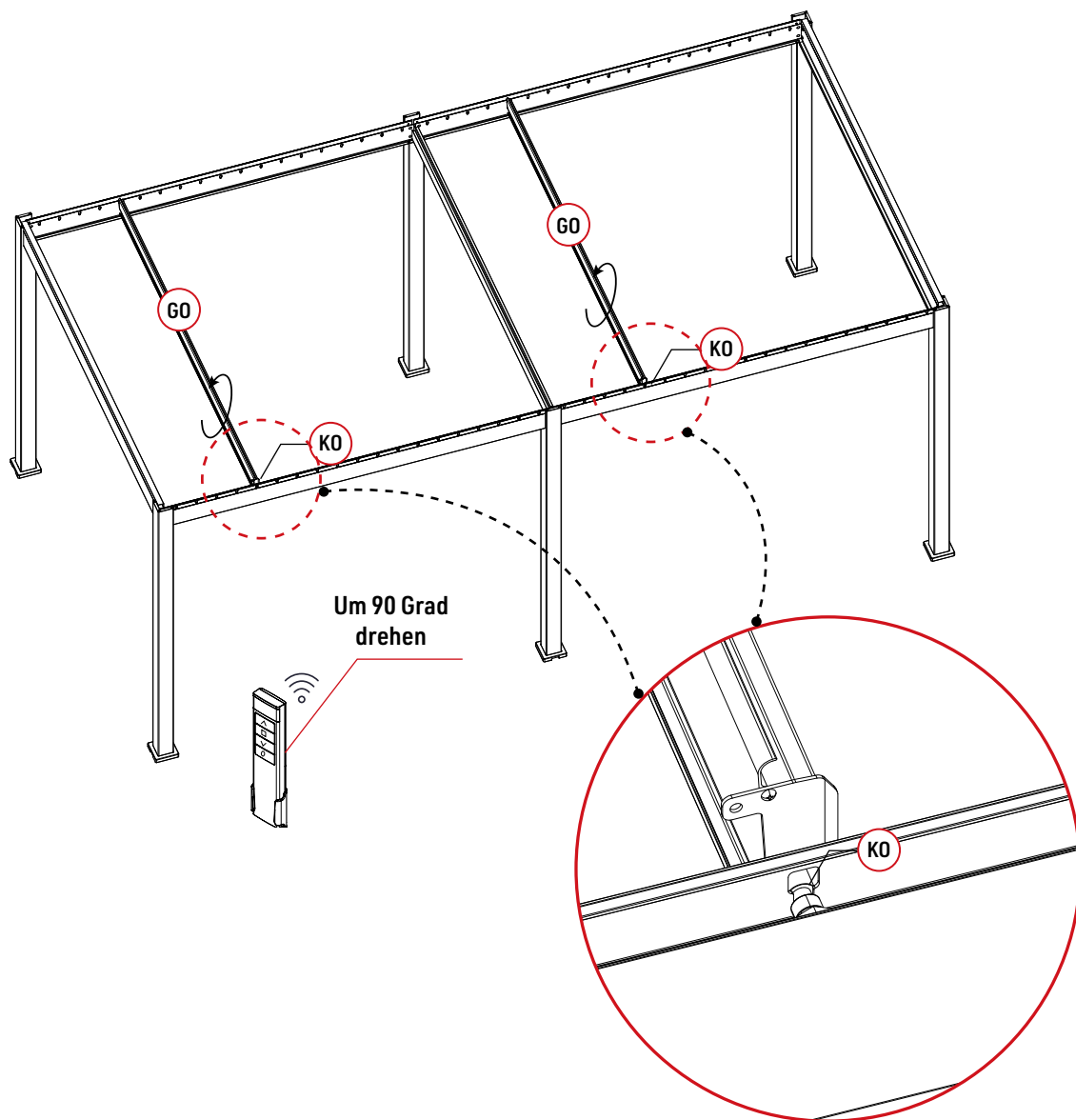

Teile

S0		76
----	-----------------------------------------------------------------------------------	----

1. Installieren Sie die anderen Lamellen auf dem Balken und stellen Sie die Lamellen flach.
2. Bedecken Sie den Schraubenkopf mit Kunststoffkappen.

1

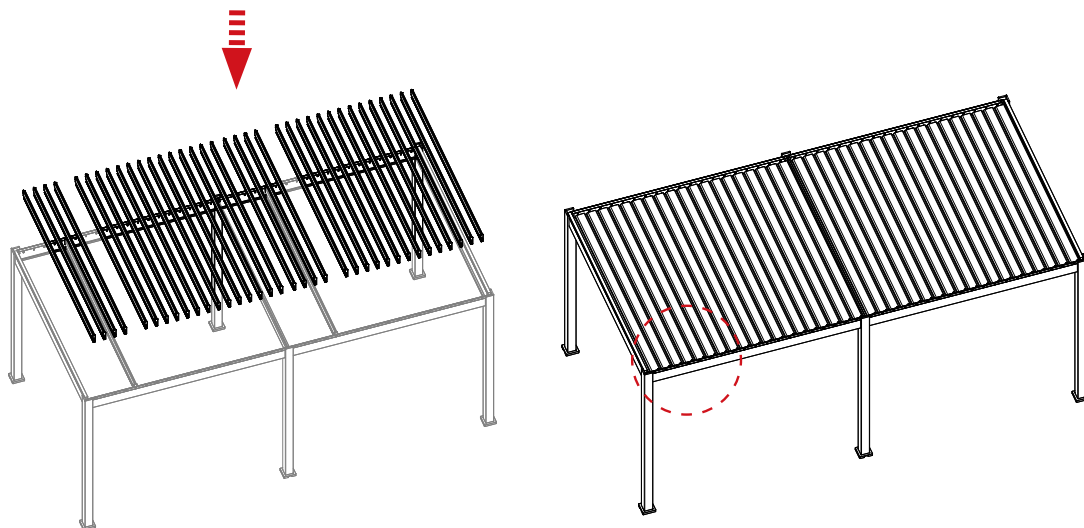

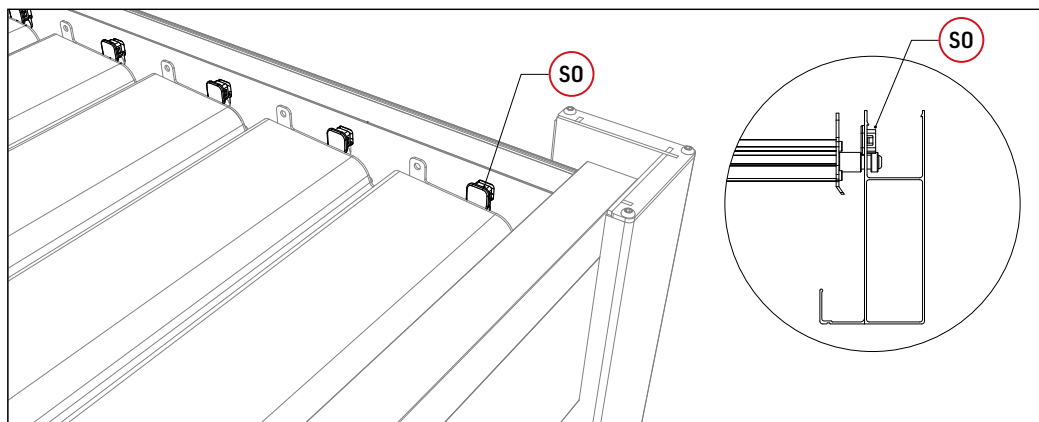

2



Schritt 3: Verbindungen

3-5

Teile

FO		2
VO		38
UO	 lock nut	38

Werkzeuge

Z0-1	 4mm	1
Z0-2	 4mm	1
Z0-5	 10mm	1

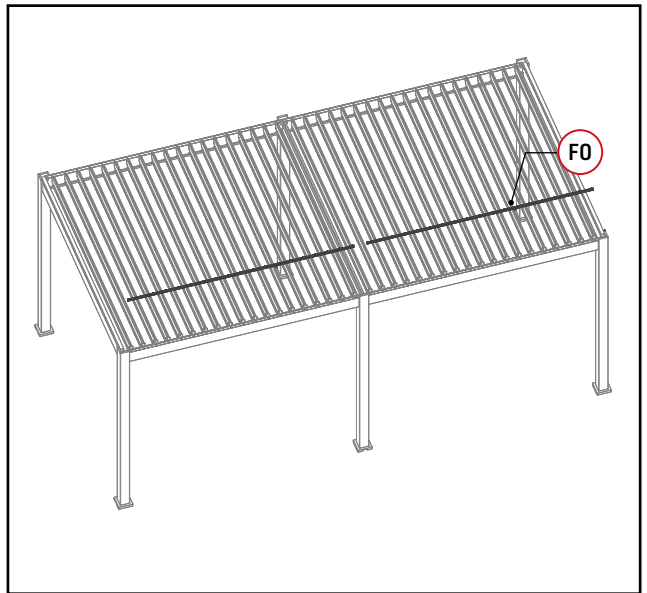



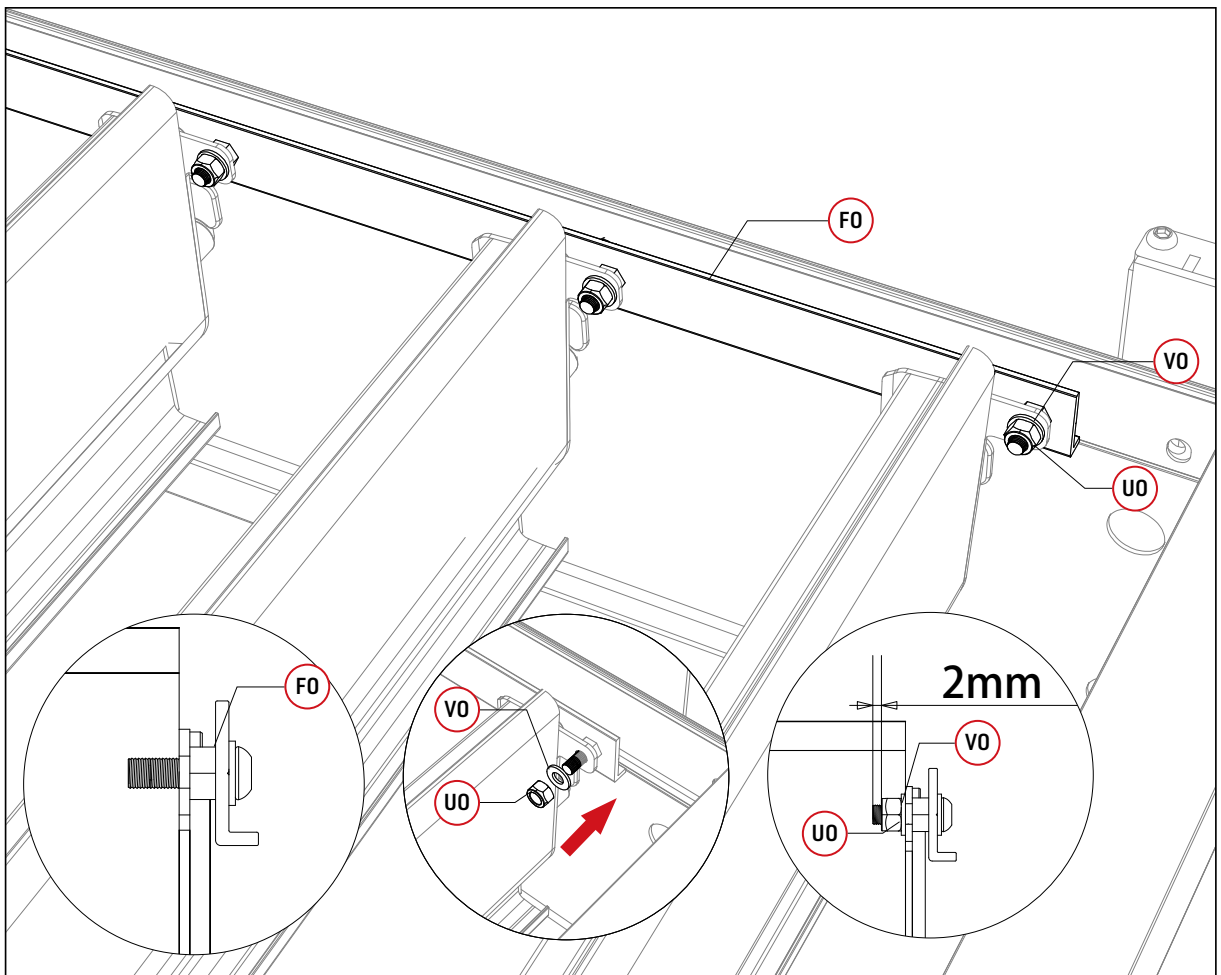

Schließen Sie die Verbindung der Lamellen mit dem FO-Teil ab.



Schritt 3: Verbindungen

3-6

Teile

DO			4
RO			24
TO		10x80	24

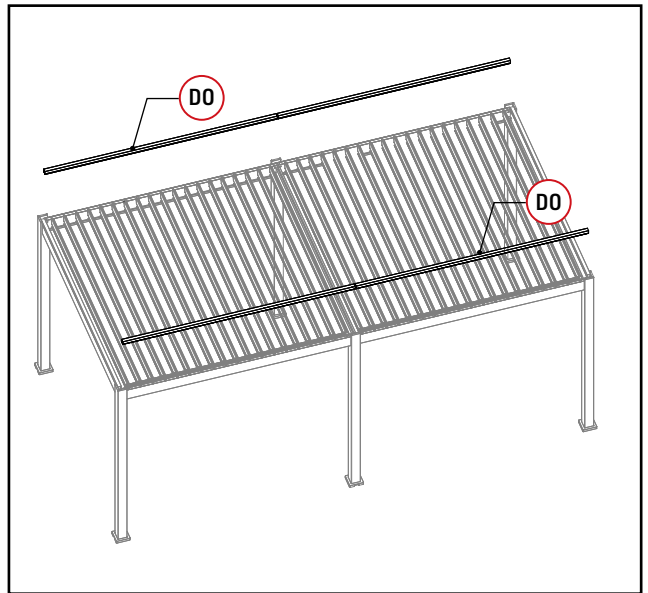

Schließen Sie die Abdeckung, um die Befestigung der Pergola zu beenden.

1

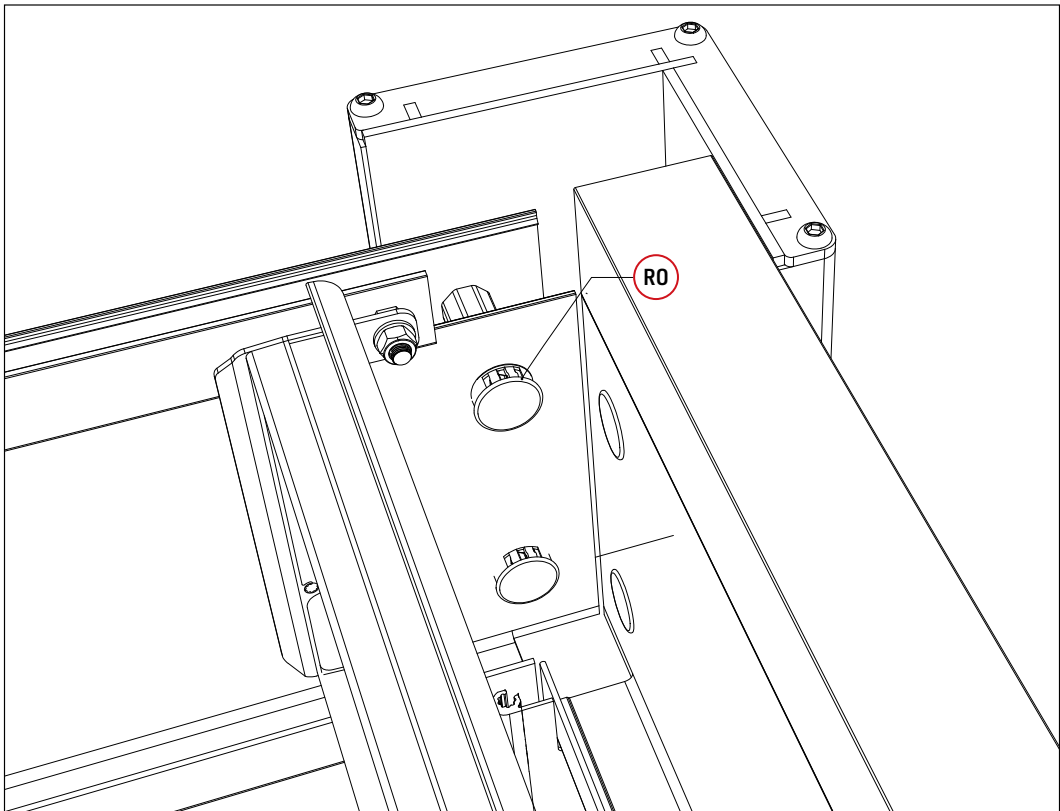

2

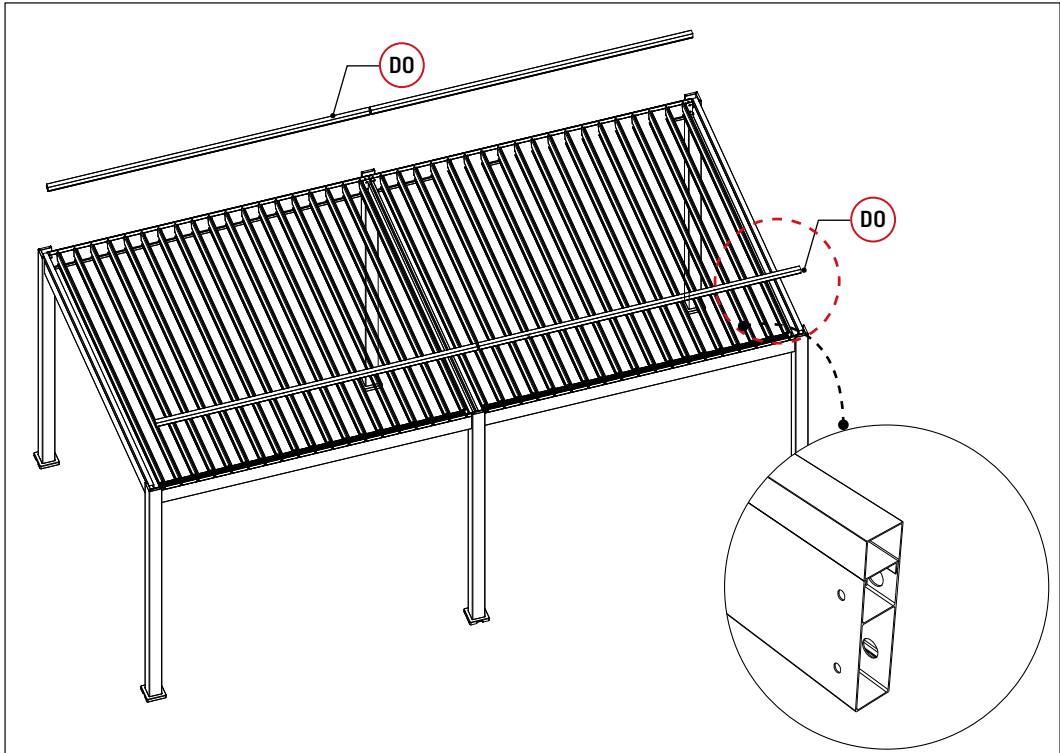

3



Prüfen Sie, ob alle Fundamente richtig dimensioniert sind, und befestigen Sie dann alle Bodenplatten.

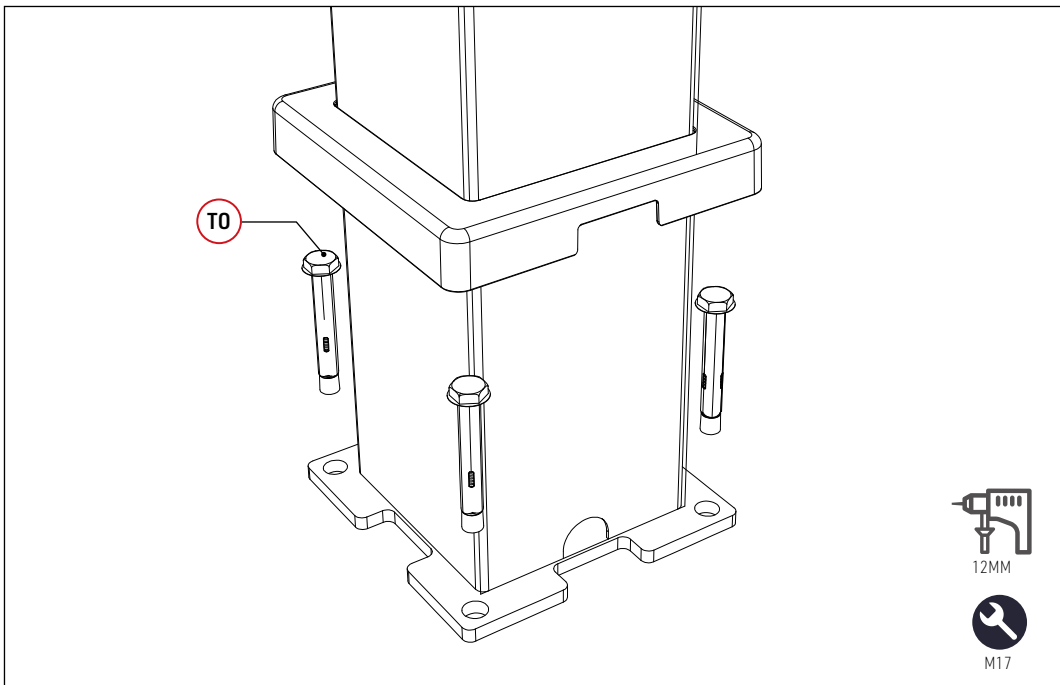

3x6 meter Pergola Electric, Aluminum

Assembly Instructions - EN

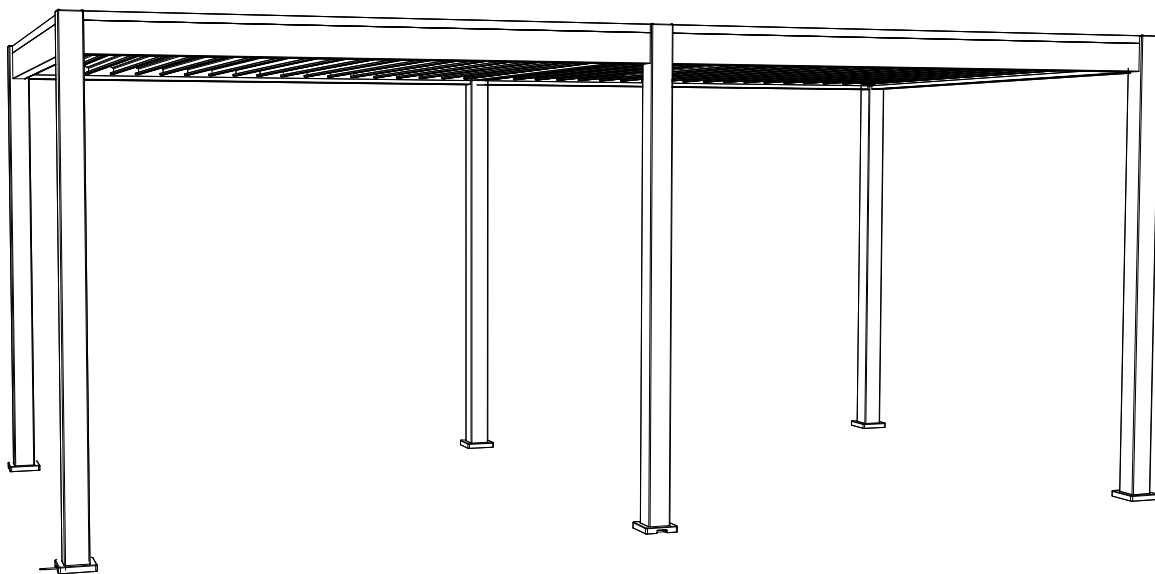

E-Deluxe Aluminum Pergola 3×6 meter

These instructions have to be saved during the whole product life cycle. We advise you to read these very carefully before proceeding to the assembly. The user will be reliable for any damages or injuries caused due to incorrect or improper installation.

NECESSARY TOOLS AND SAFETY GEAR (NOT SUPPLIED)

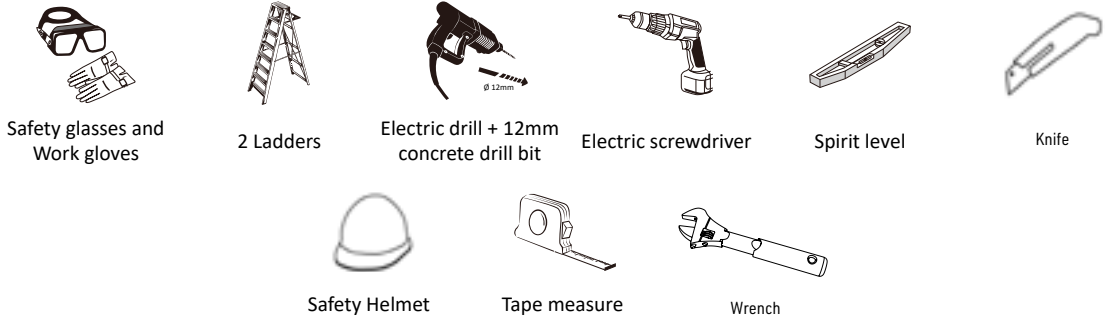

2D FOOTING MEASUREMENT (dimensions in mm)

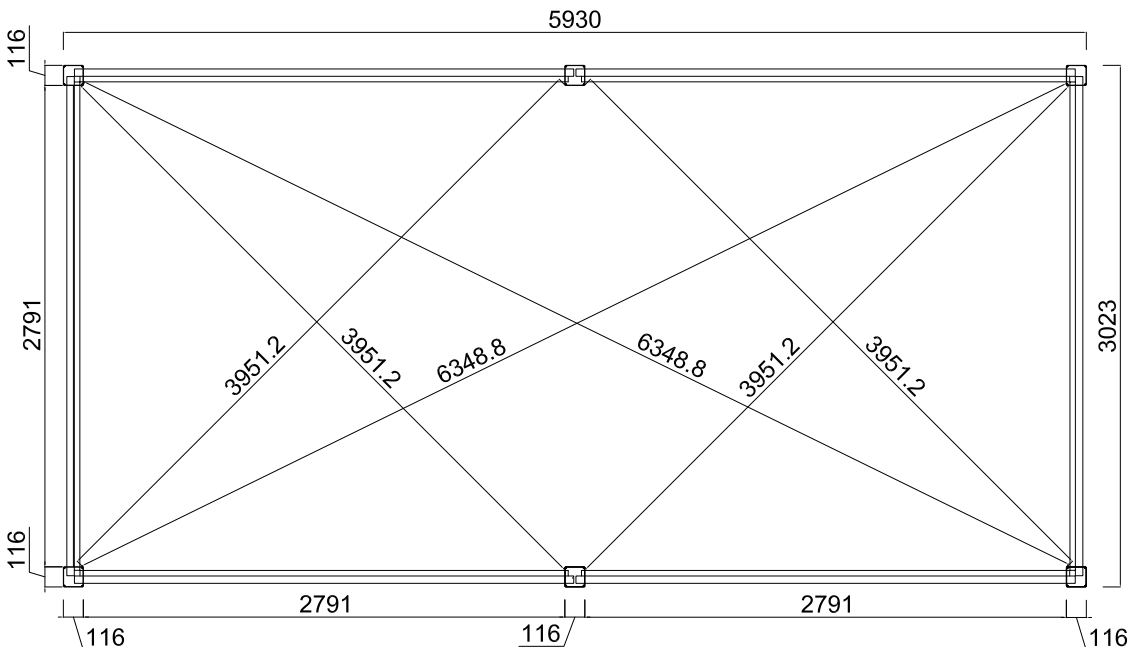

3D FOOTING MEASUREMENT (dimensions in mm)

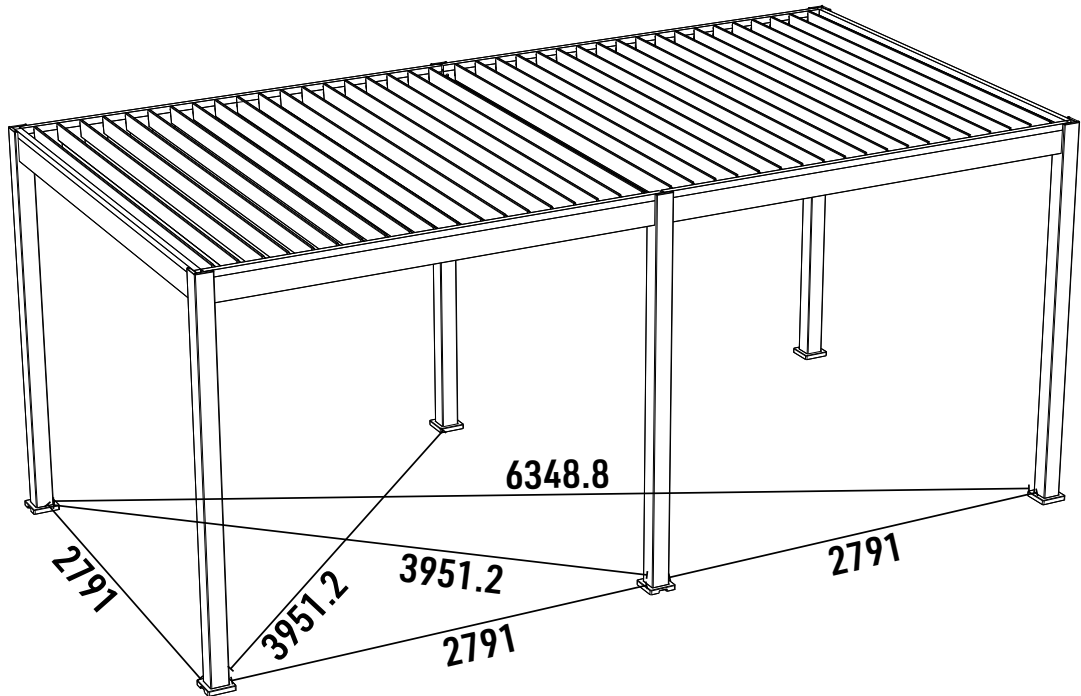

PRECAUTION OF USE

This product should not be used in extreme weather: storms, violent winds, hail, and snow. We guarantee the resistance of the pergola for winds up to 88 km/h and a maximum snow weight of 50kg/m².

As in the case of strong winds or snow, we highly recommend leaving the louvers open. To maintain good working conditions of your louvers, please clear any snow on them.

Our pergola can withstand heavy rain, but we cannot guarantee it will be 100% waterproof due to some extreme weather conditions.

Exceptional climatic events may compromise the perfect sealing of the product.

To avoid any damages and injuries, we do not recommend climbing on the roof or the structure of the pergola.

TIPS AND SAFETY INSTRUCTIONS

Depending on the location and surface area, construction may be subject to building permits. Make sure you have checked with your local authorities to obtain the needed information before the assembly.

Product assembly :

- At least 2/3 people required
- Remove protective film (around 1 hour needed)
- Do not keep children near the assembly area
- Beware of the risk of pinching
- Do not tighten the screws before assembling the whole product
- All assembly steps must be carefully followed
- Check the level of the structure on all sides
- Do not anchor the pergola before assembling the whole product

No changes can be made to the product. Products tampered with by the user are not covered by the warranty, thus being declared as void.

The location should be chosen carefully. It is recommended to avoid mounting your pergola on a rainy day, facing the prevailing winds, and under an overhanging tree.

The pergola must be mounted on a flat-level foundation. It is recommended to install it on a concrete slab or 25x25 cm concrete pads at each post. Please, anchor the pergola properly to the ground using expansion screw.

If you would like to mount your pergola near your house or a building, please check the presence of gutters for water drainage.

Should these instructions not be followed or only partially, the warranty will be voided by the seller.

MAINTENANCE

Regular maintenance is necessary to ensure its longevity and aesthetic appearance.

We recommend to :

- Clean your pergola once or twice a year with fresh water using a sponge or cloth.
- Do not use detergent or an abrasive material.
- Check the tightness of the screws regularly (at least once a year).
- Oil fastening regularly (at least once a year).
- Make sure that nothing hinders the water flow in the gutters (leaves, branches...).
- Remove any water that might stagnate around the legs of the pergola (lift the posts skirts).

WARRANTY

This warranty does not cover :

- Normal wear and tear inherent from the products.
- Loss or breakage of any part during unpacking or installation.
- Lack of care, neglect, vandalism, impact with foreign body, force, contact with a brasives material, product aesthetics, disassembly, rebuilding or relocation.
- Force majeure: hail, high winds, storms, snow, floods, lightning etc...
- Product tampered with by the user.

The warranty only takes in account the replacement of spare parts or the provided product, no refund will be issued.

All warranty claims must be made at the sales outlet (store or website) where the product has been purchased.

PARTS LISTS (PER CARTON)



Before proceeding with the assembly of your louvered pergola, it is necessary to check that all parts listed are supplied and not damaged.









Any missing part must be reported within 10 days of delivery.



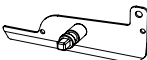
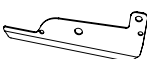







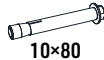



You can either go through your local outlet store or make the request directly on our website.

Do not discard the packaging without ensuring that the product is functioning properly.



CARTON 1/5(POSTS AND LOOSE PARTS)



Reference	Parts	Quantity
A0		4
A0-1		2

Reference	Parts	Quantity
I0		6
J0		6
K0		2
L0		36
LO-1		38
EO-1		2
M0		74
Q0		24
RO		24
SO		76

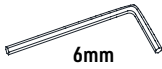
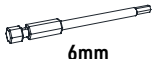

Reference	Parts	Quantity
T0	 10×80	24
U0	 lock nut	112
U0-3	 M14	2
W0	  PH2	152
W0-1	  5×19 5mm	6
X0	  6×40 4mm	74
X0-1	  6×35 4mm	24
X0-3	  6×16 4mm	4
V0		38

CARTON 1/5(POSTS AND LOOSE PARTS)



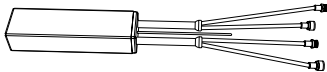

Reference	Parts	Quantity
ZO-1	 4mm	1
ZO-2	 4mm	1
ZO-3	 6mm	1
ZO-4	 6mm	1

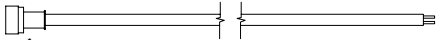
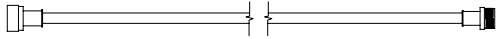
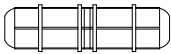
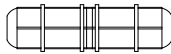
Reference	Parts	Quantity
ZO-5	 10mm	1
ZO-6	 PH2	1
ZO-7		1

Electrical products

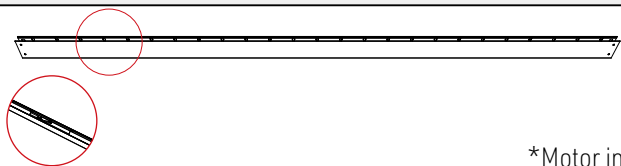
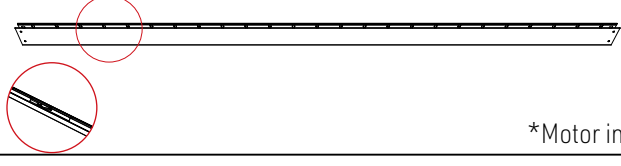
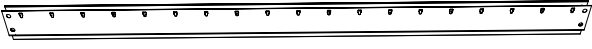
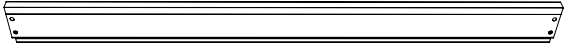
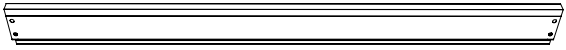
Reference	Parts	Quantity
E-C	 Controller	1
E-R	 Remote control	1
E-P	 Power cable(M15)	1
E-P1	 Motor connection cable(M12)	1
E-W2	 Waterproof joint(2)	1
E-W3	 Waterproof joint(3)	1

CARTON 2/5(BEAMS)

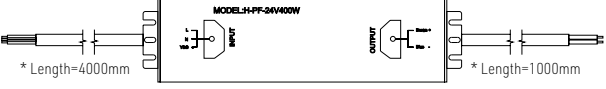
Reference	Parts	Quantity
B1	 <p>*Motor inside</p>	1
B2	 <p>*Motor inside</p>	1
BO-1		2
CO		1
CO-1		1
DO		4
FO		2
EO		1
E-T	 <p>Transformer</p>	1



ATTENTION!

Connecting Bar(FO) & Brush Inside!

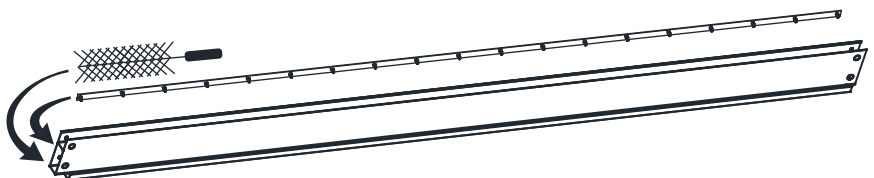

CARTON 3/5(LOUVERS)

Reference	Parts	Quantity
GO		13

CARTON 4/5(LOUVERS)

Reference	Parts	Quantity
GO		13

CARTON 5/5(LOUVERS)

Reference	Parts	Quantity
GO		12

ASSEMBLY GUIDELINES

Step 1: Frame & Motor

Step 2: Assembling louvers

Step 3: Install louvers & Connection

Step 1: Frame & Motor

Notes:

1. Please put the transformer into the side beam where is close to the motor.
2. Put the input wire of the transformer through the post, then pull the line from the notch at the base of post, to connect the power.
3. Please connect wiring in accordance with the diagram below.

E-T	 <p>Transformer</p>	1
-----	------------------------------------------------------------------------------------------------------	---

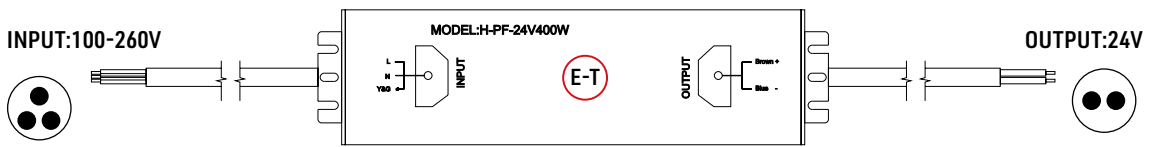

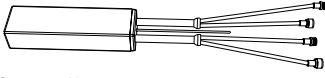
E-C	 <p>Controller</p>	1
-----	-----------------------------------------------------------------------------------------------------	---

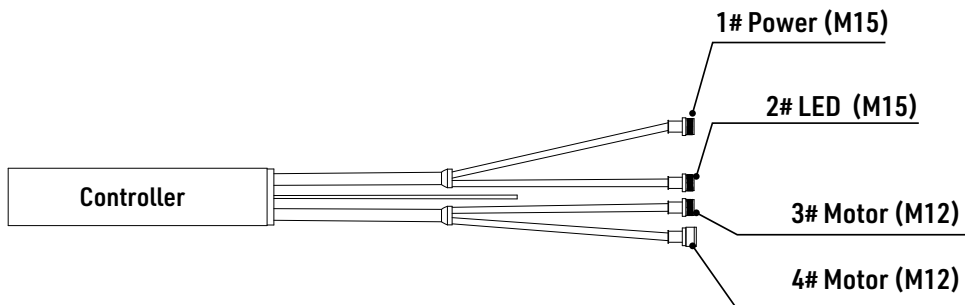

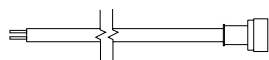
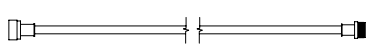
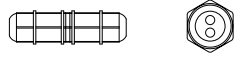
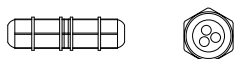
E-P		1
E-P1		1
E-W2		1
E-W3		1

Step 1: Frame & Motor

Motor, Controller and Transformer
Location in the Pergola

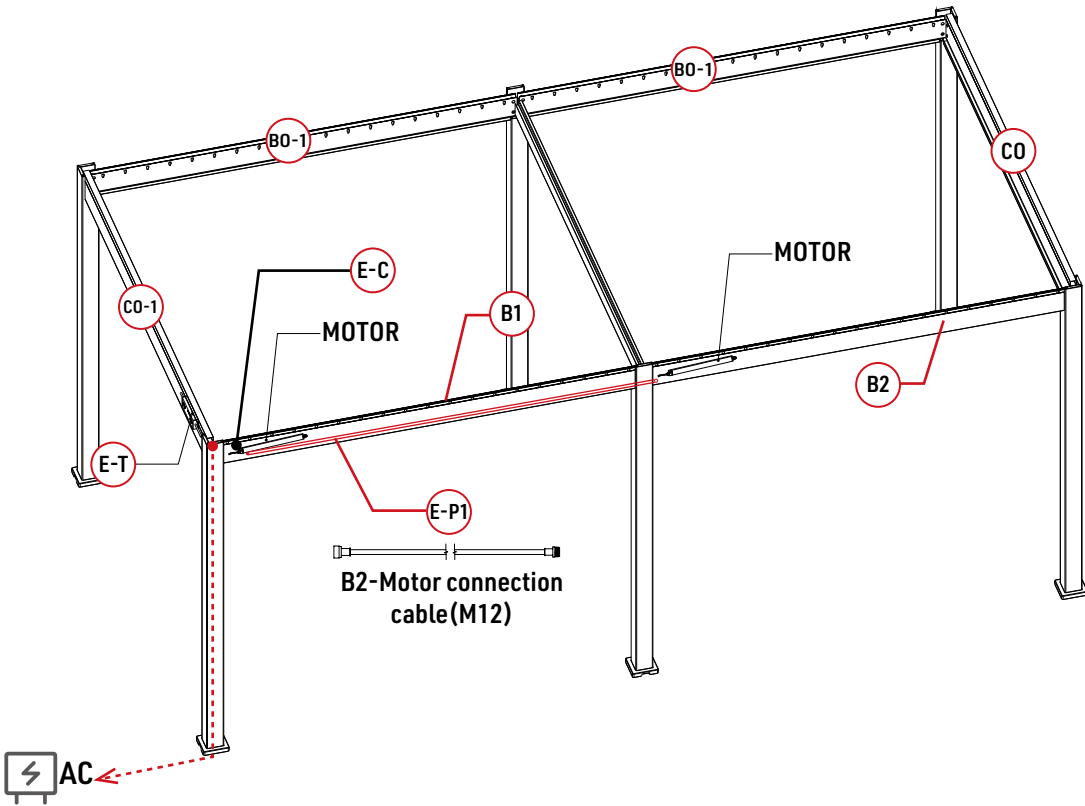



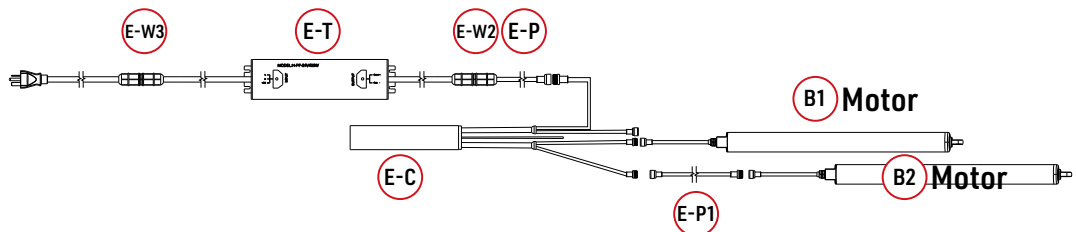

Wiring Diagram





Step 1: Frame & Motor

1-1

Parts

A0		4
I0		4
J0		4
X0-1	 6x35 4mm	16

Tools

Z0-1	 4mm	1
Z0-2	 4mm	1

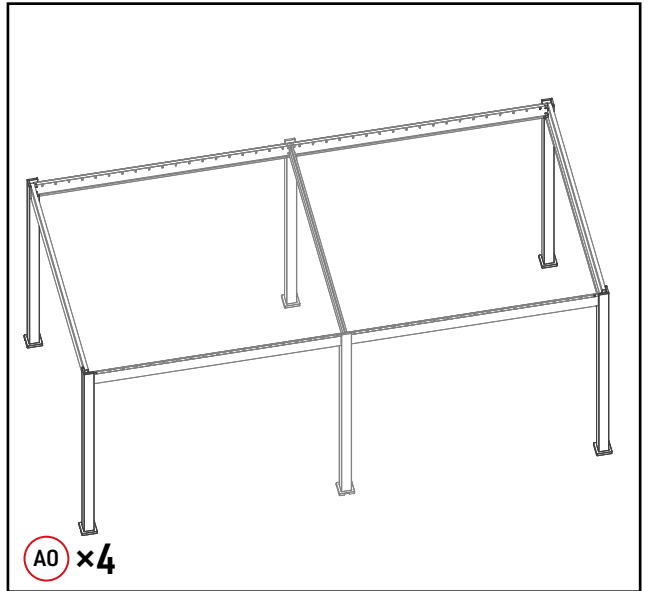

Post installation diagram

1.

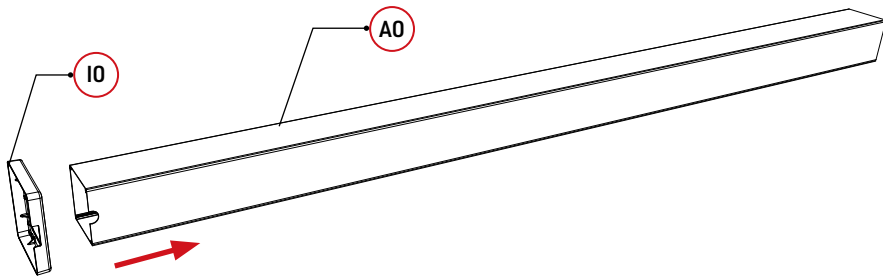

2.

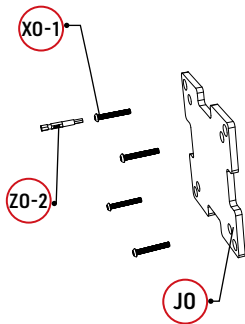



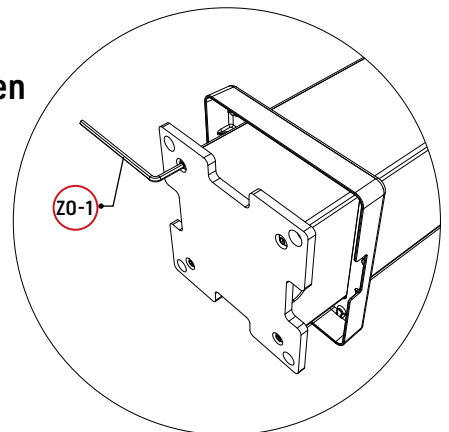

3. Tighten





Step 1: Frame & Motor

1-1

Parts

A0-1		2			
I0		2	X0-1		8
J0		2			

Tools

Z0-1		1
Z0-2		1

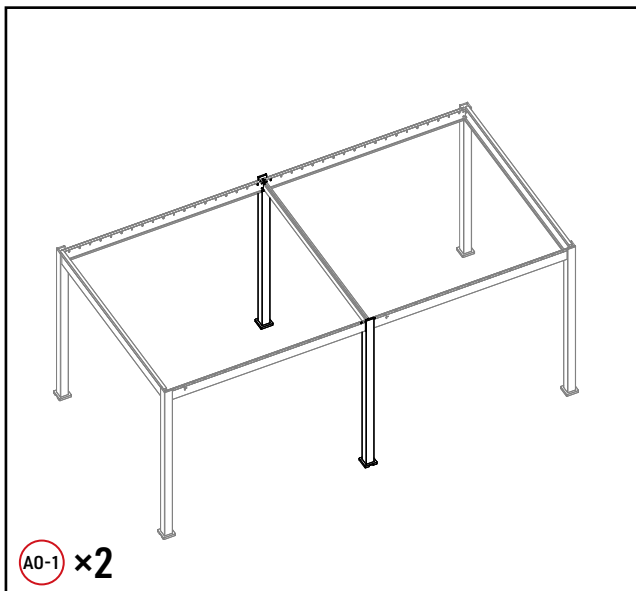

Post installation diagram

1.

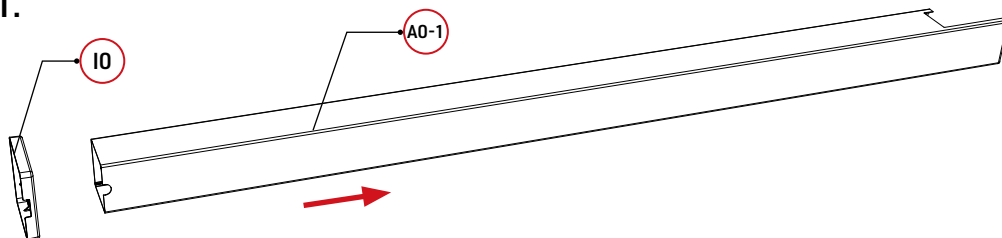

2.

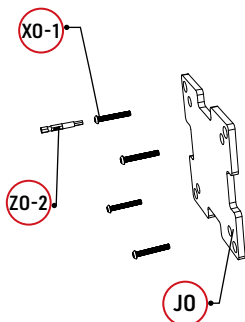

3. Tighten

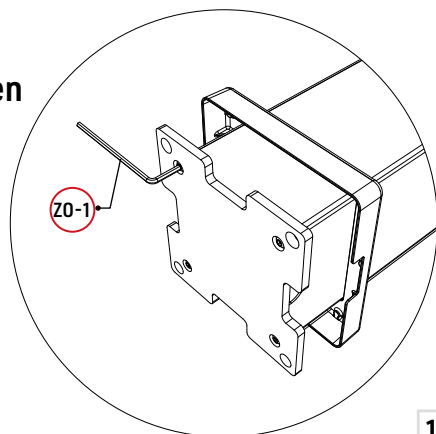

Step 1: Frame & Motor

1-2

Parts

B1		1
B2		1
B0-1		2
D0		4

Remove the end caps from the beam

1.

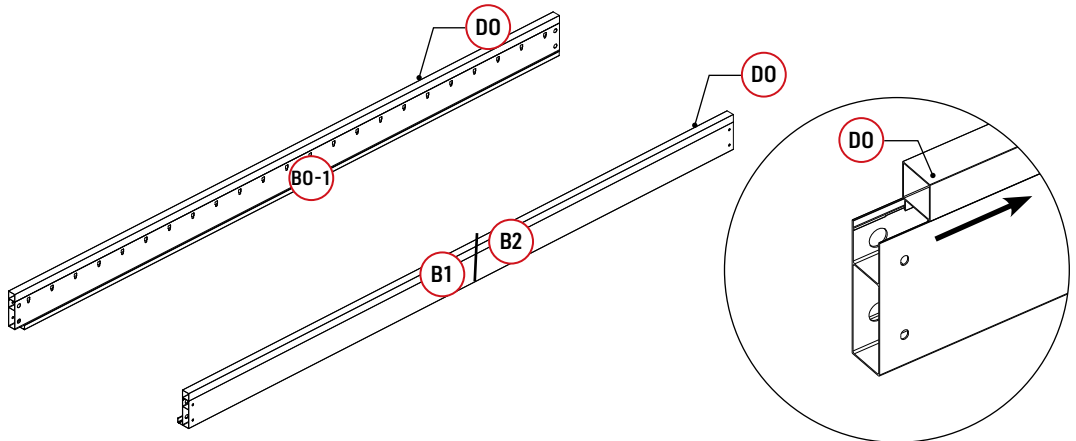

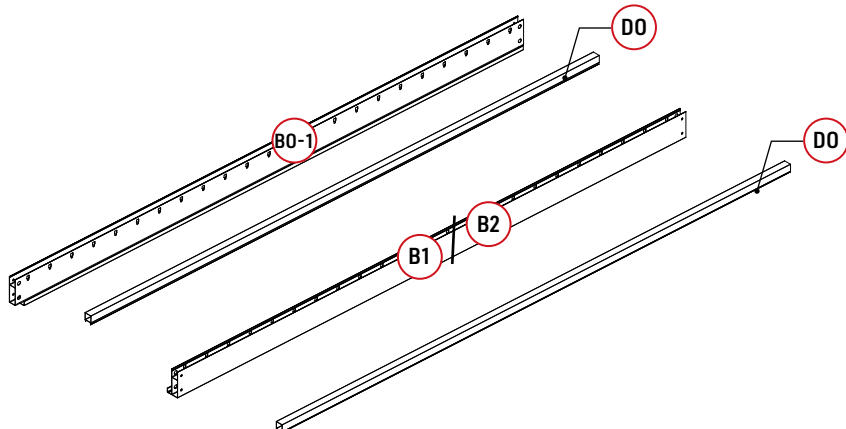

2.



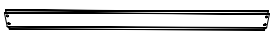

Step 1: Frame & Motor

1-3

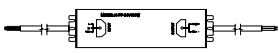

Parts

CO		1
CO-1		1

E-T	 Transformer	1
-----	--------------------------------------------------------------------------------------------------	---

Q0	 6mm	8
----	---------------------------------------------------------------------------------------	---

Tools

Z0-3	 6mm	1
Z0-4	 6mm	1

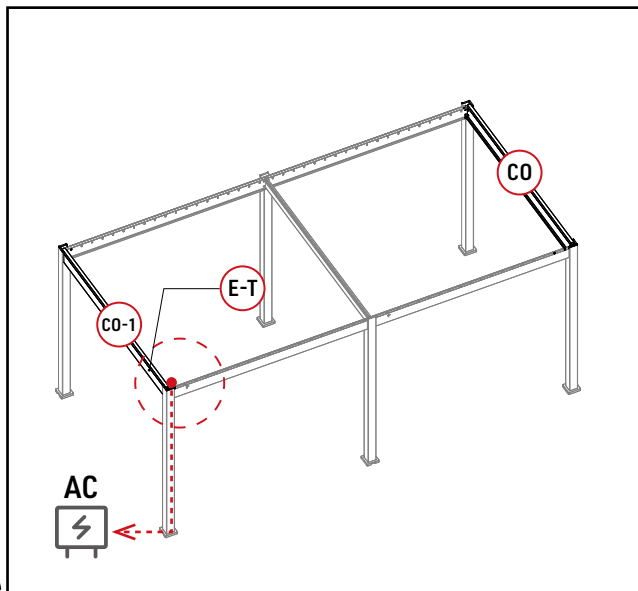

Connect beams to posts

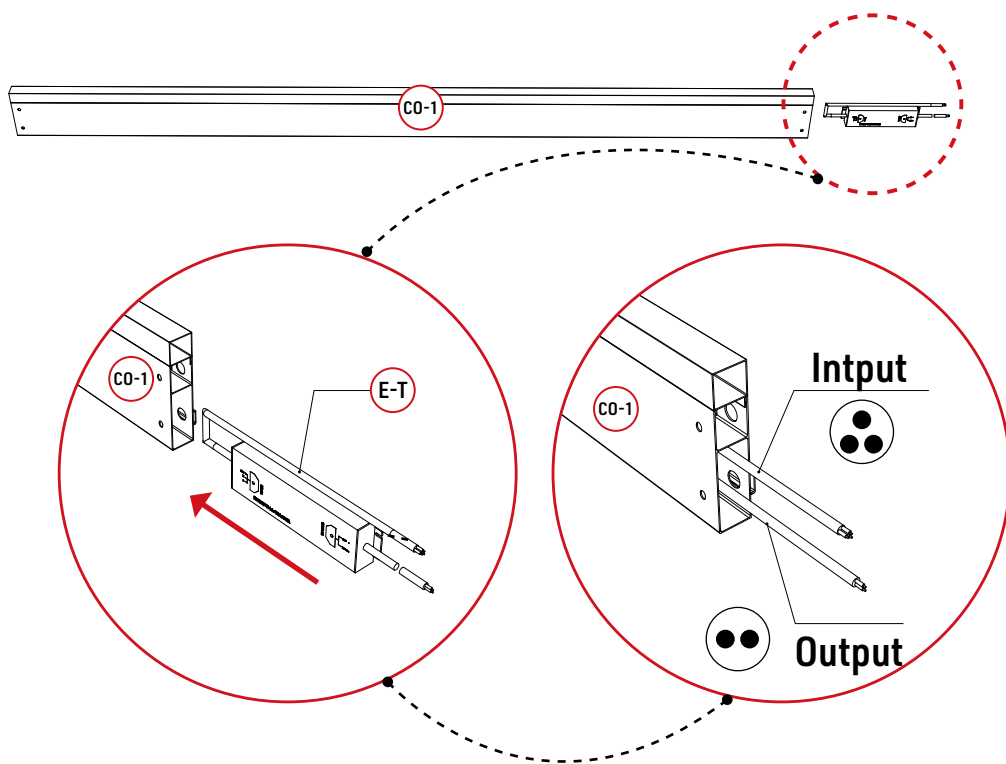

Step 1: Frame & Motor

1-3

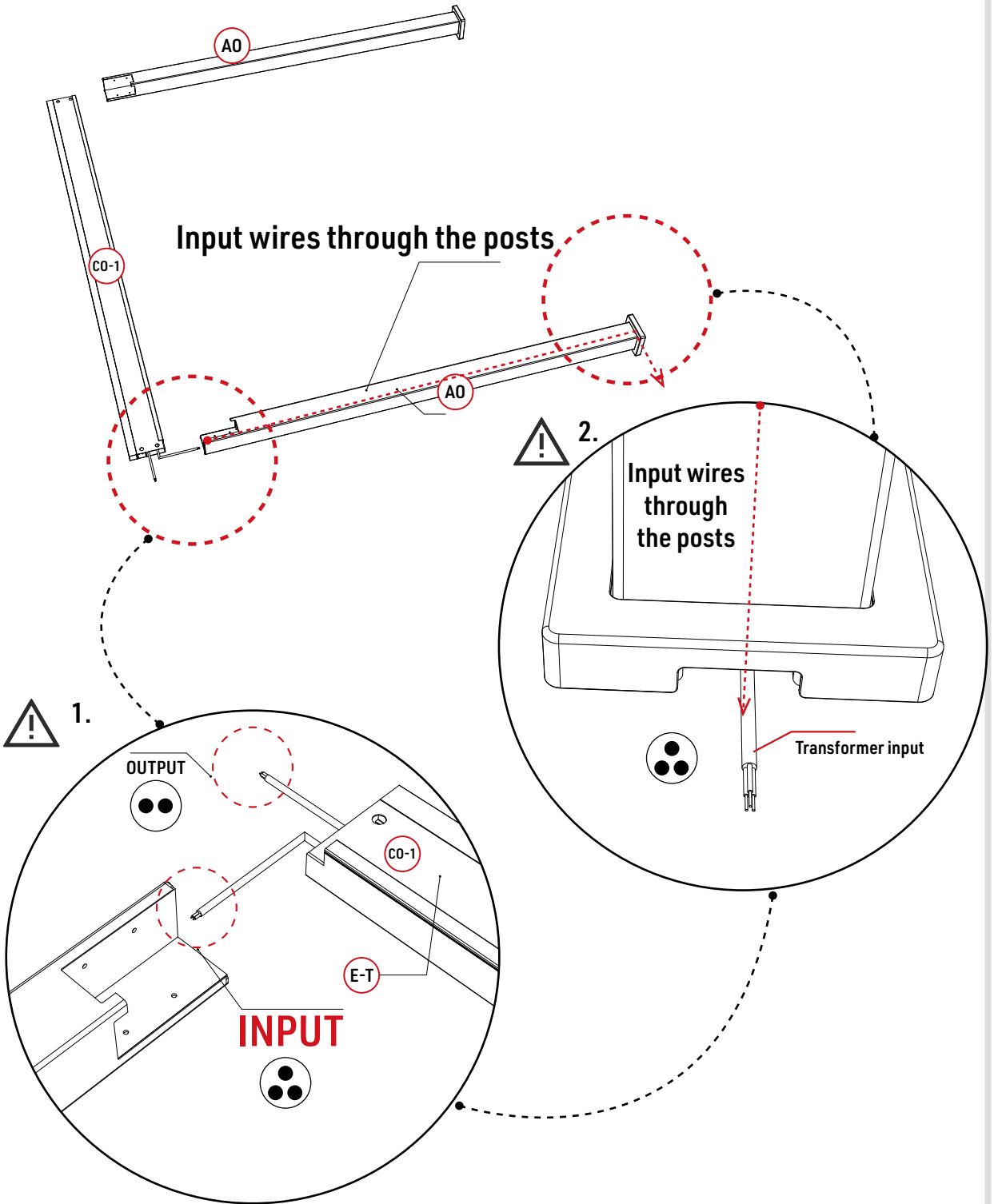

Step 1: Frame & Motor

1-3

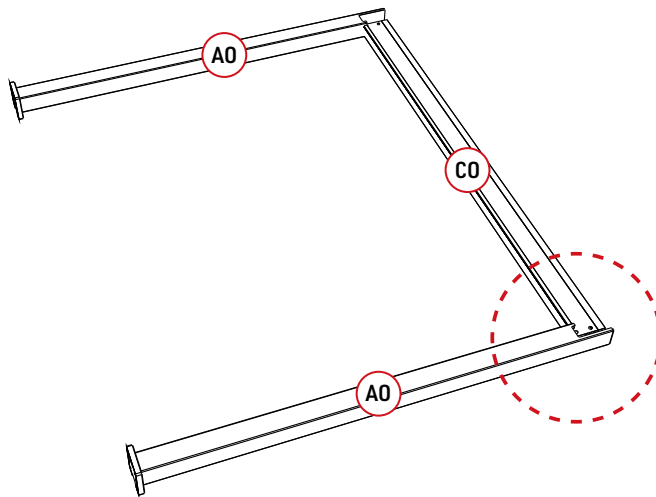
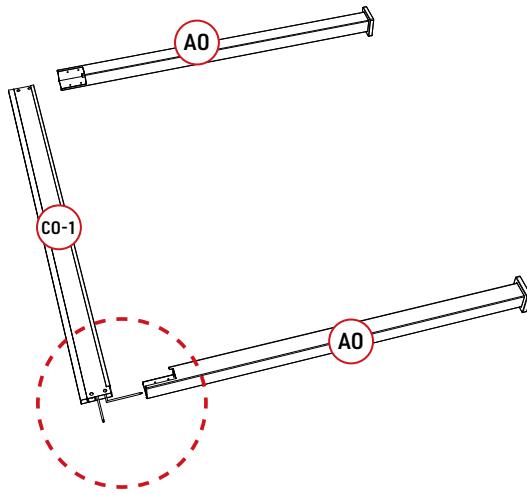

1.

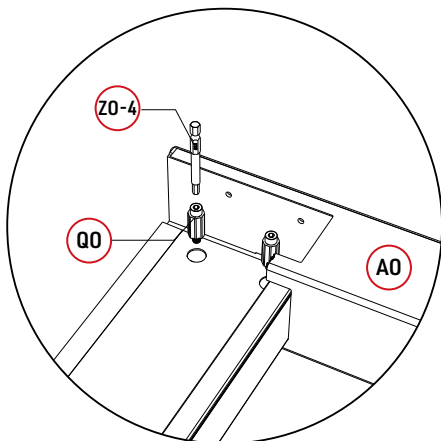



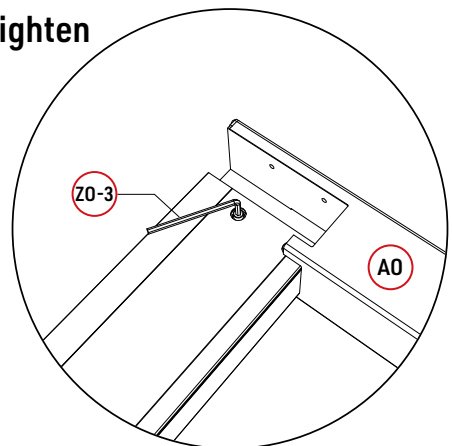

2. Tighten





Step 1: Frame & Motor

1-4

Parts

B1		1
B2		1
BO-1		2
Q0	 6mm	16

Tools

Z0-3	 6mm	1
Z0-4	 6mm	1

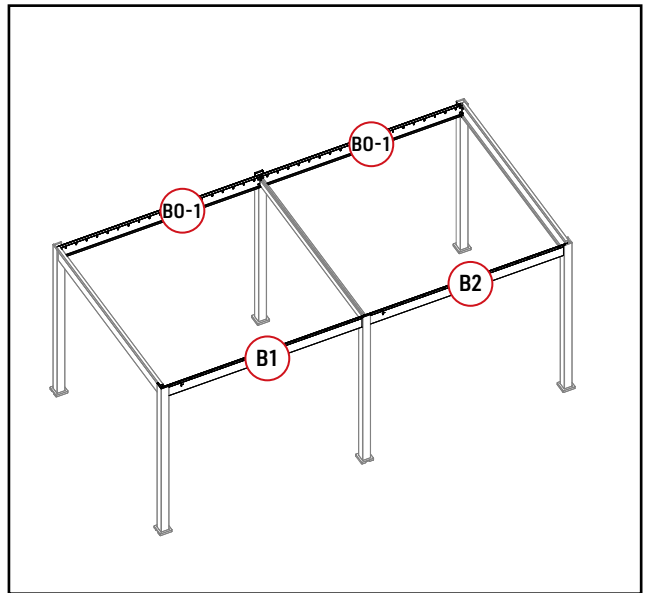

Connect beams to posts

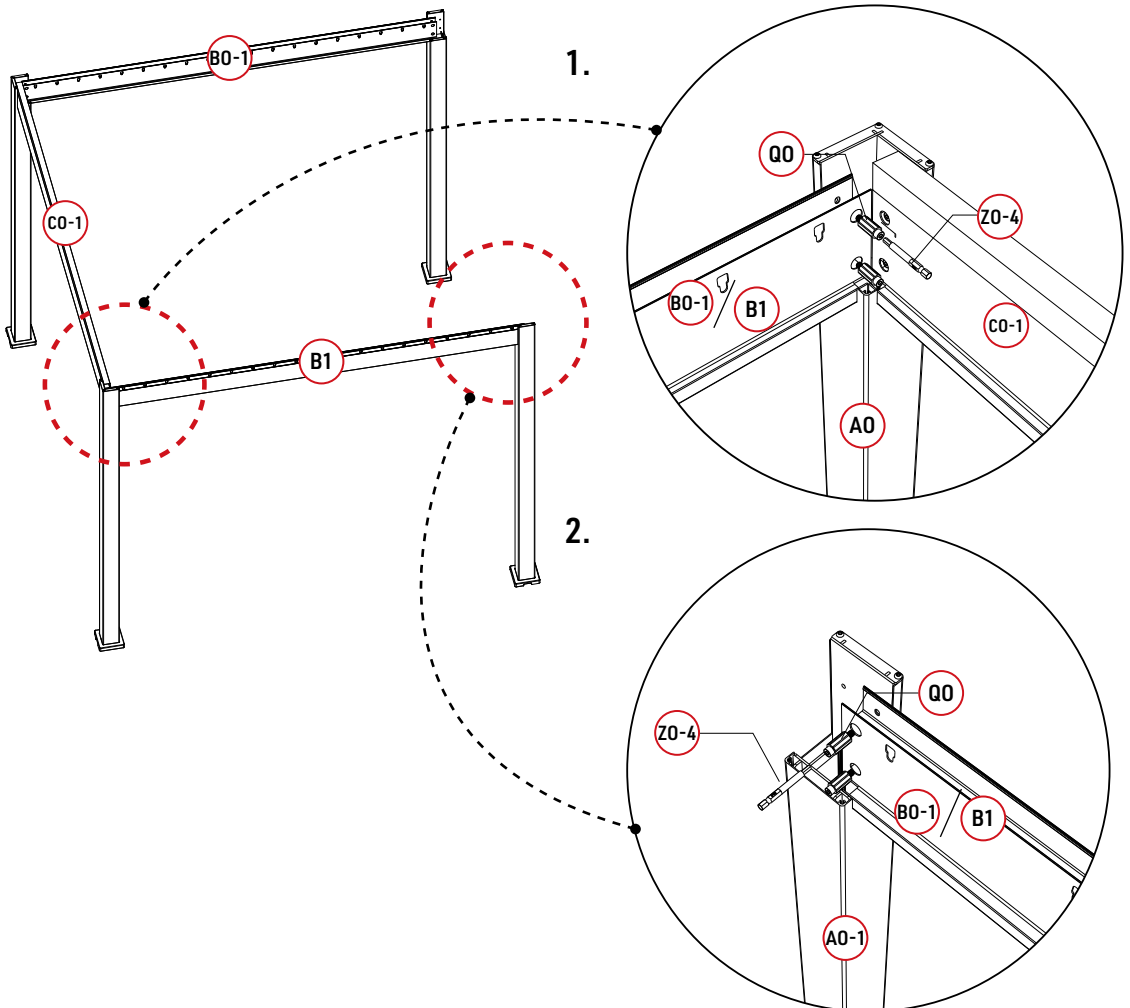

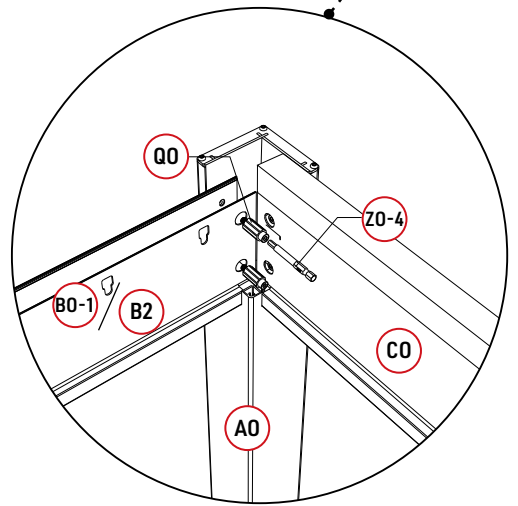
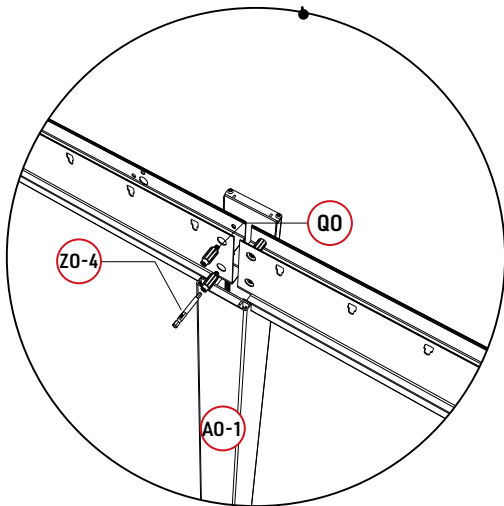
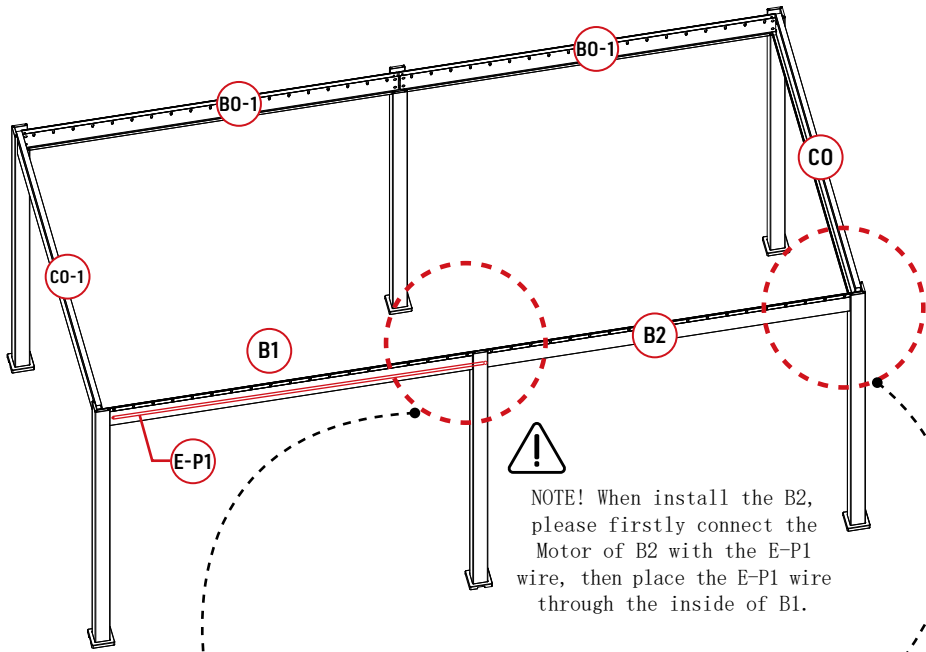

Tighten

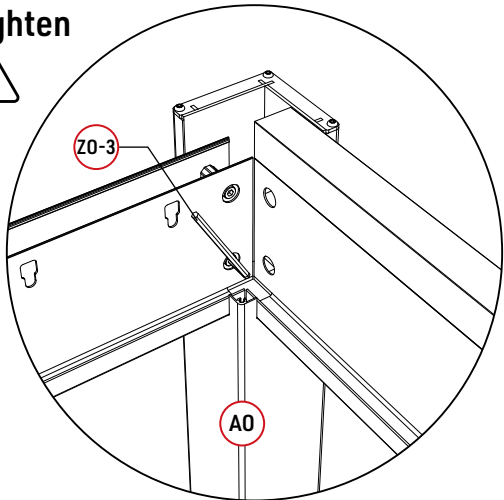

Tighten

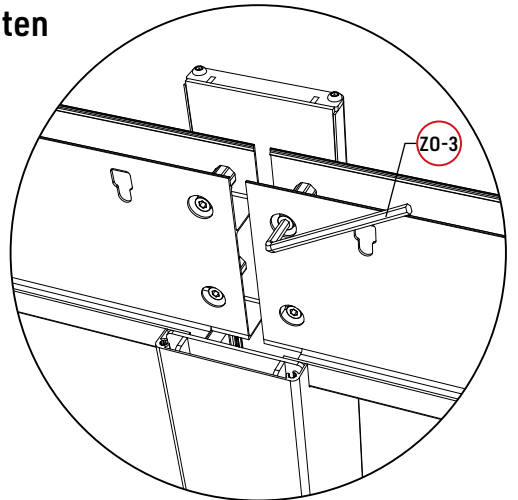

Step 1: Frame & Motor

1-5

Parts

E0		1
----	-----------------------------------------------------------------------------------	---

EO-1		2
------	-----------------------------------------------------------------------------------	---

WO-1	 5x19	 5mm	6
------	----------------------------------------------------------------------------------------	---------------------------------------------------------------------------------------	---

XO-3	 6x16	 4mm	4
------	----------------------------------------------------------------------------------------	---------------------------------------------------------------------------------------	---

Tools

ZO-1	 4mm	1
------	---------------------------------------------------------------------------------------	---

ZO-2	 4mm	1
------	---------------------------------------------------------------------------------------	---

ZO-7		1
------	-----------------------------------------------------------------------------------	---

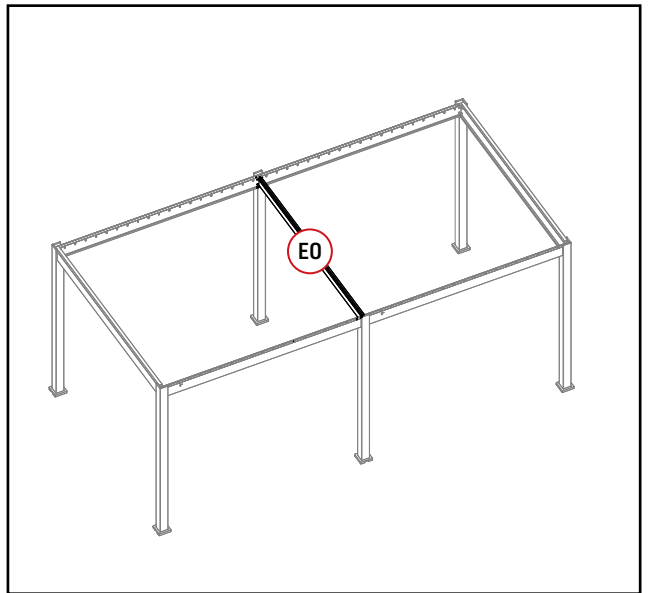

Connect beams to posts

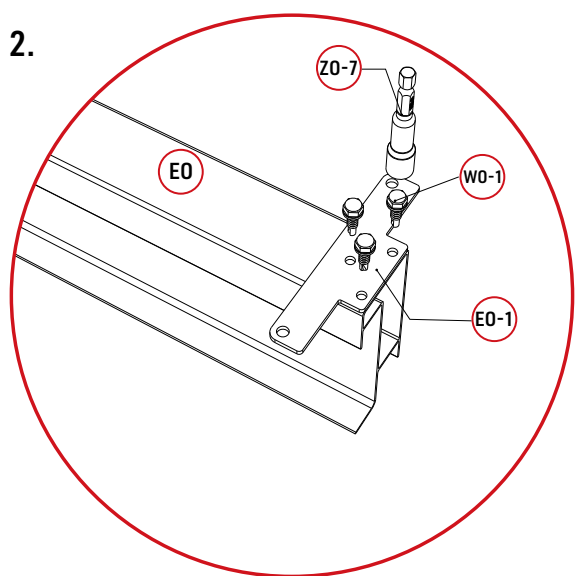
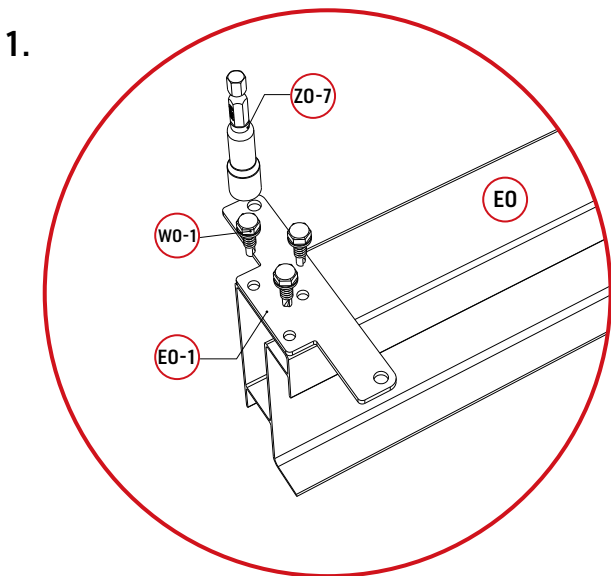
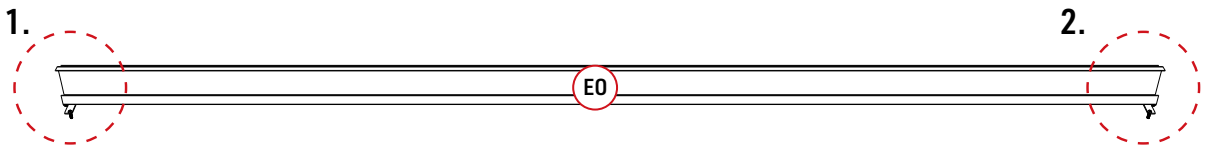

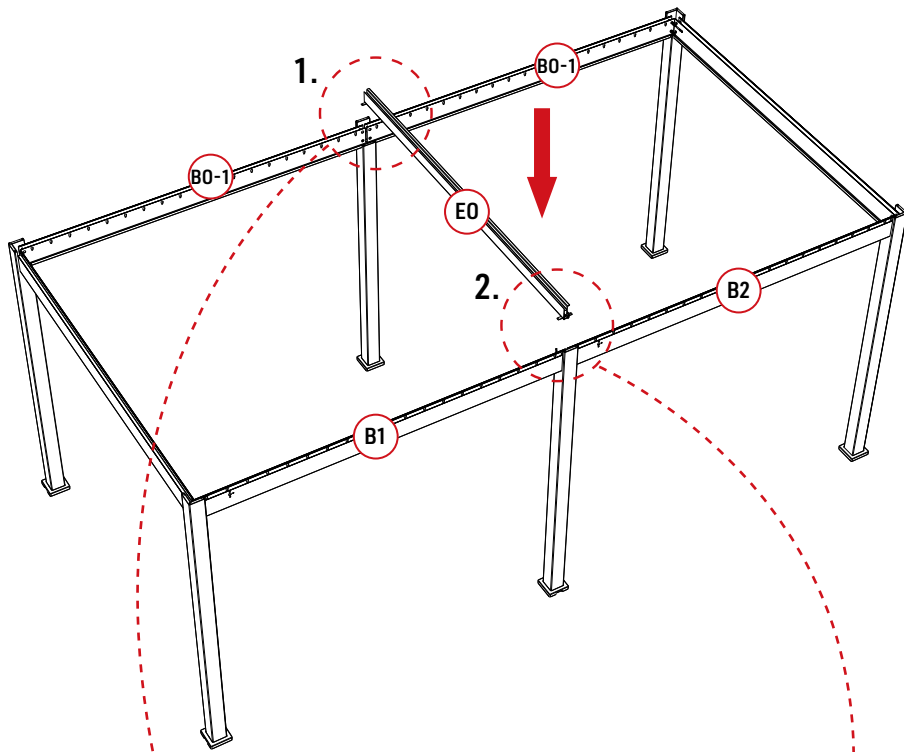

1.

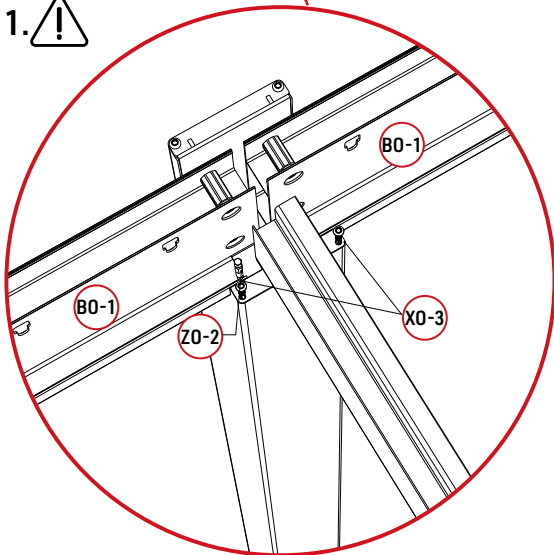

2.

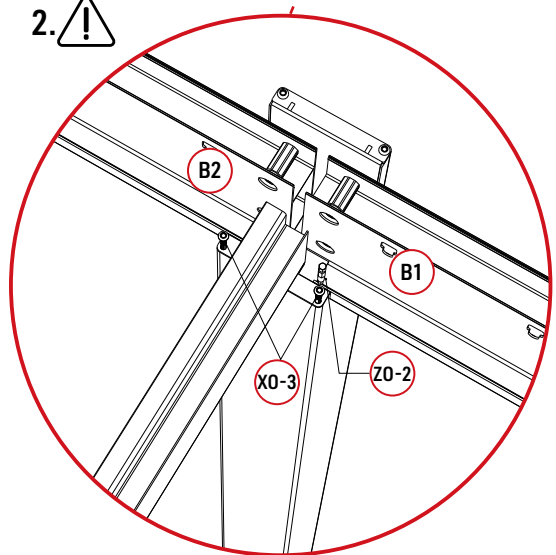



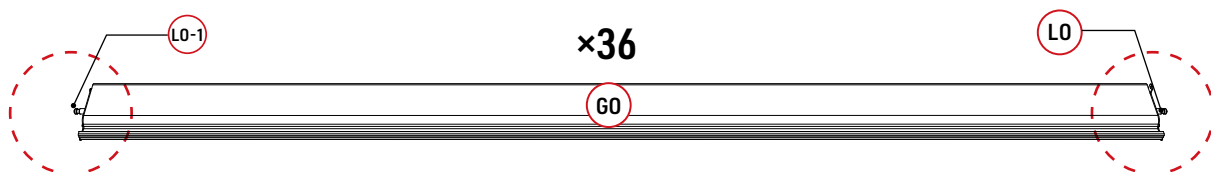
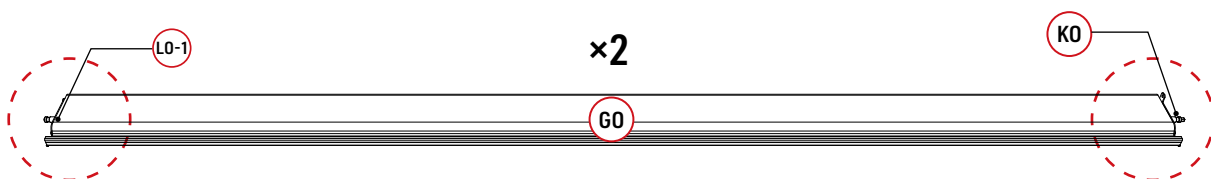
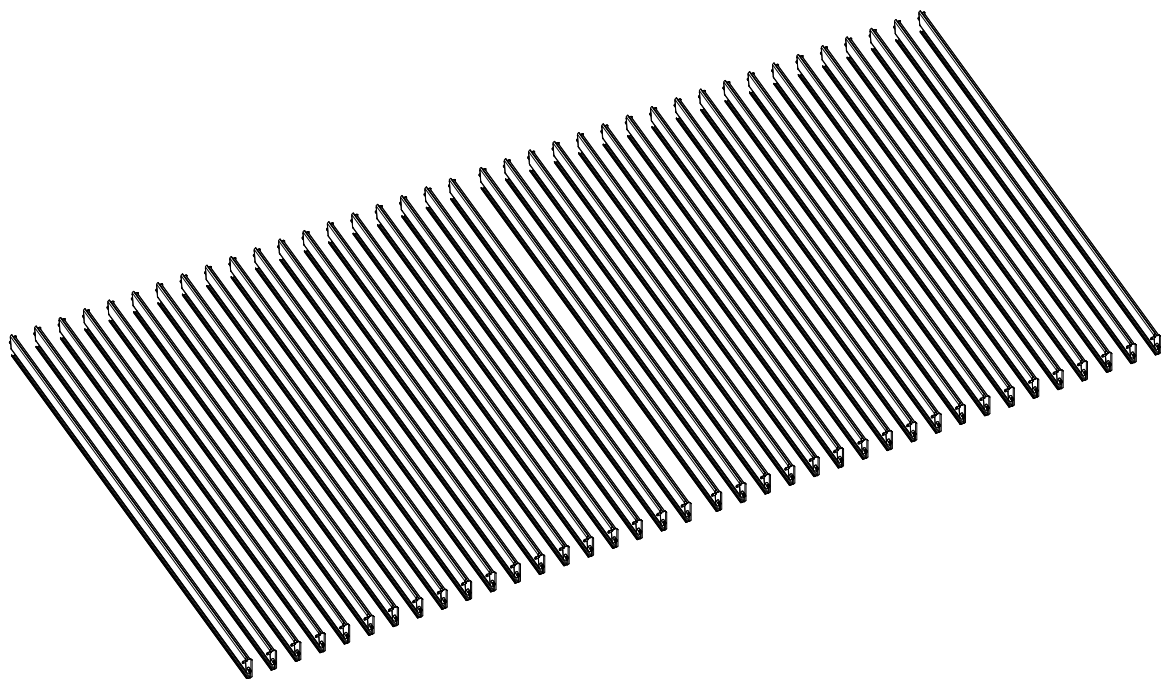

Step 2: Assembling louvers





Step 2: Assembling louvers 2-1

Parts

LO		36	XO		74
LO-1		38	UO		74
MO		74			

Tools

ZO-1		1
ZO-2		1

Install louvers end cap

LO ×36

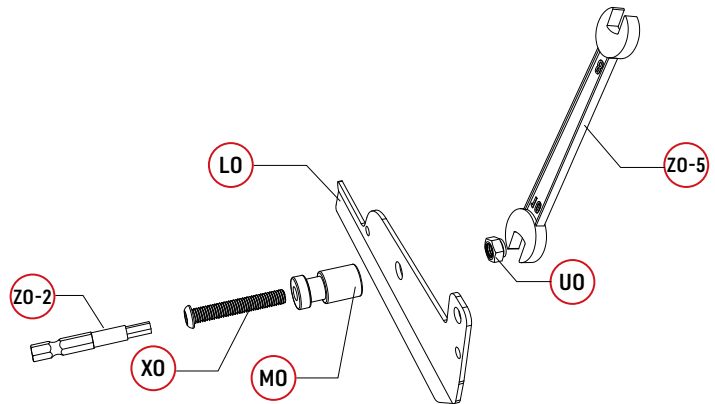
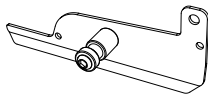



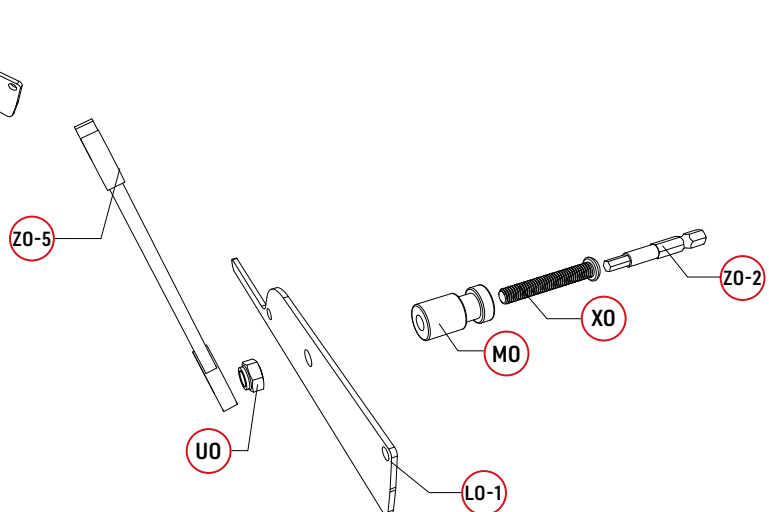
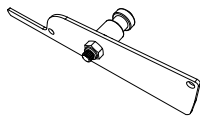

Install louvers end cap

LO ×38





Step 2: Assembling louvers 2-2

Parts

GO		38
KO		2
LO		36
LO-1		38
WO		152

Tools

ZO-1		1
ZO-2		1
ZO-6		1



GO ×38

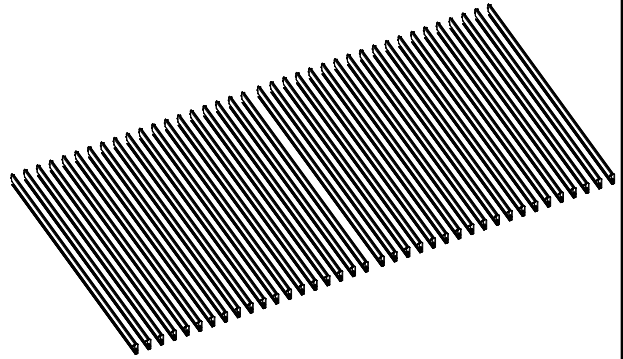

Connect end caps with the two louvres

Completion Diagram

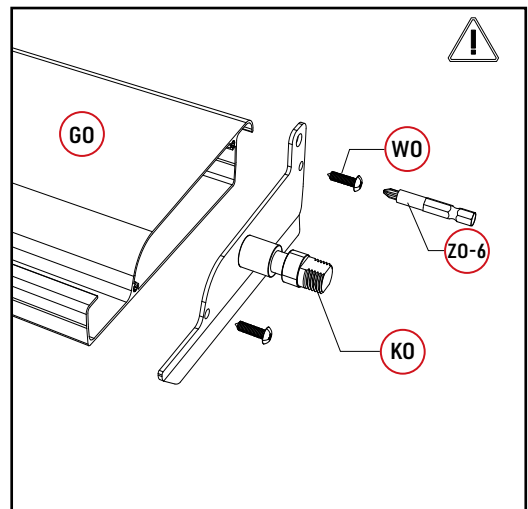
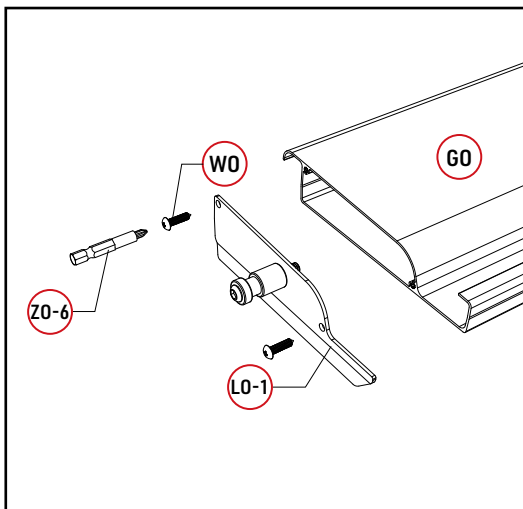
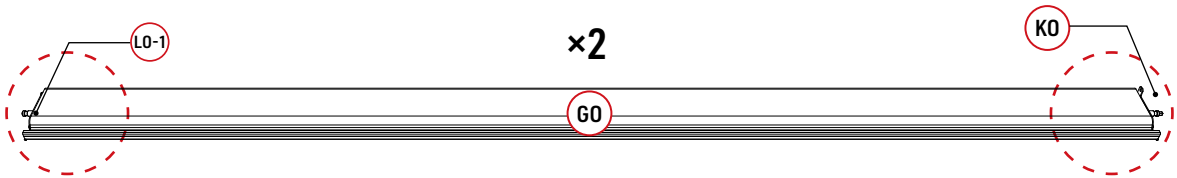

Connect end caps with the rest louvers

Completion Diagram

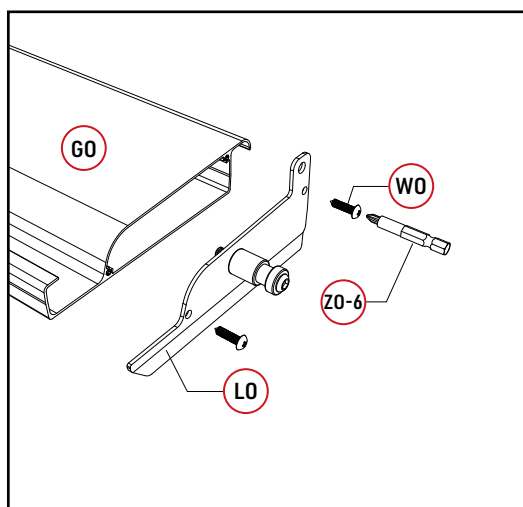
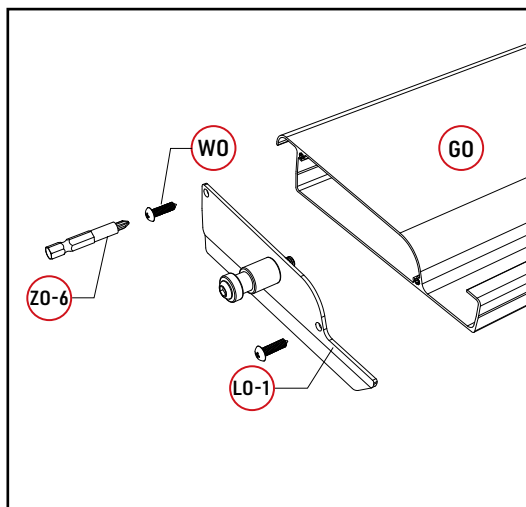
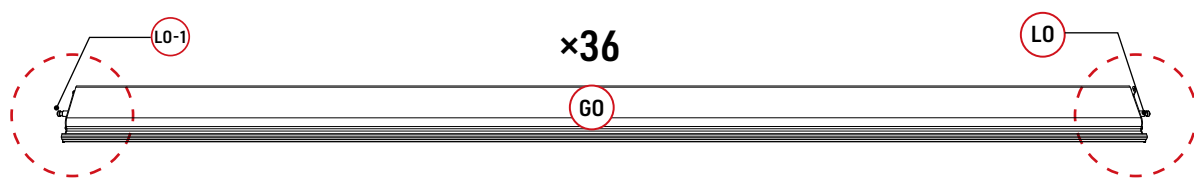

Step 3: Install louvers & Connection

3-1

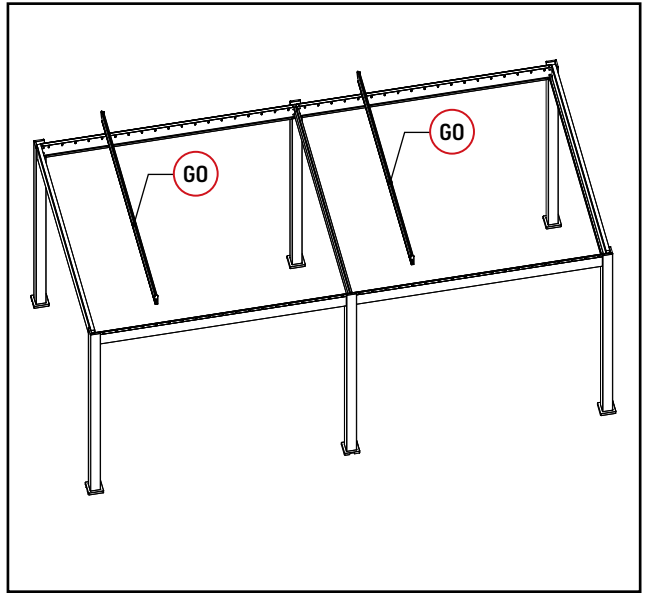

Install the the two first louvers on the beam

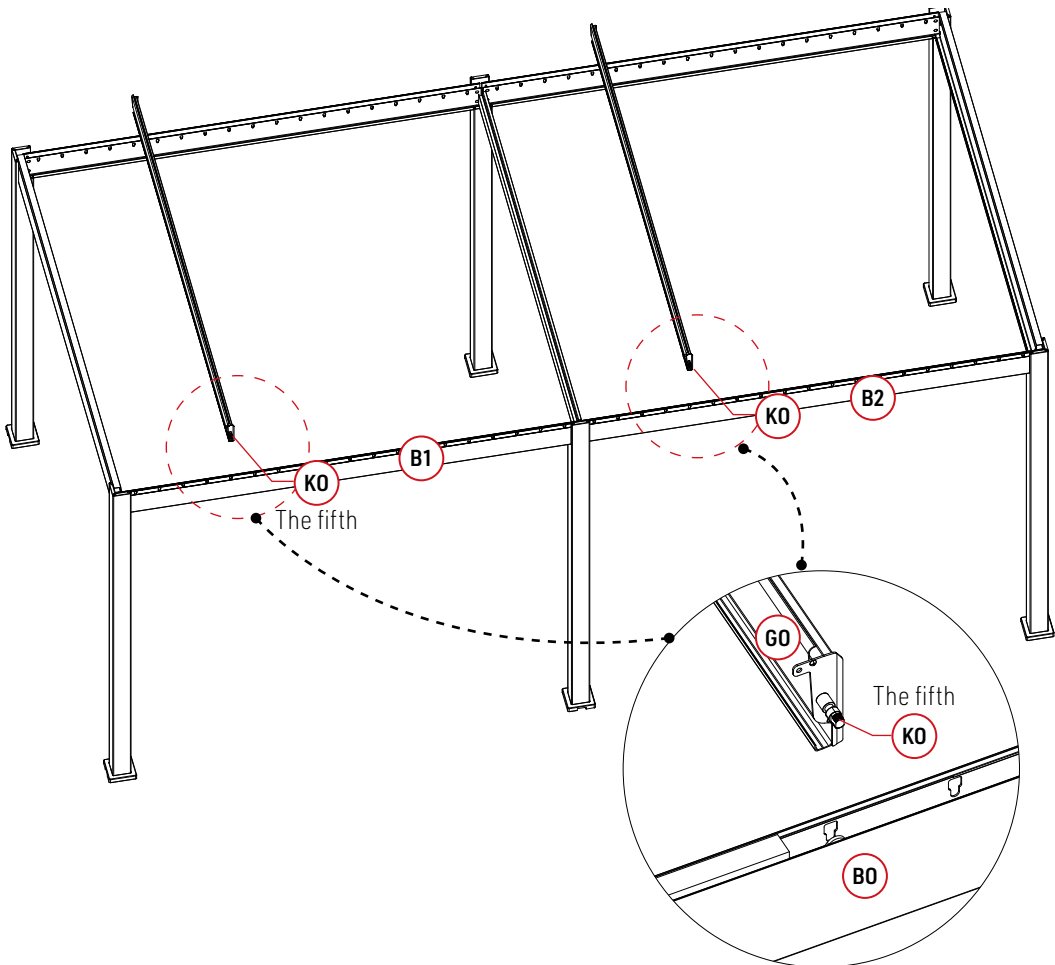

1

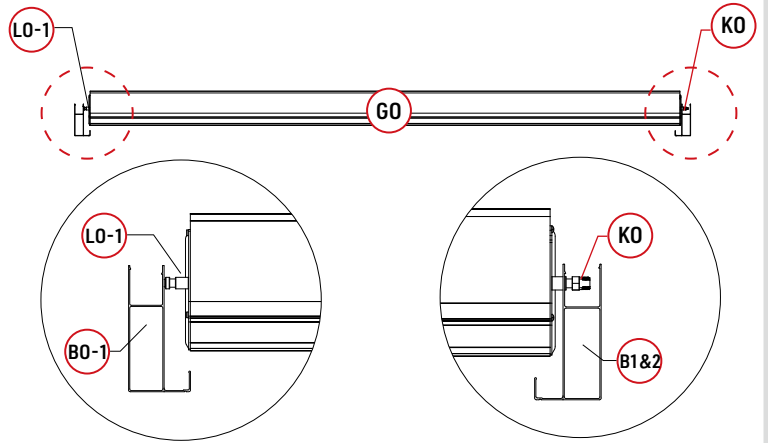
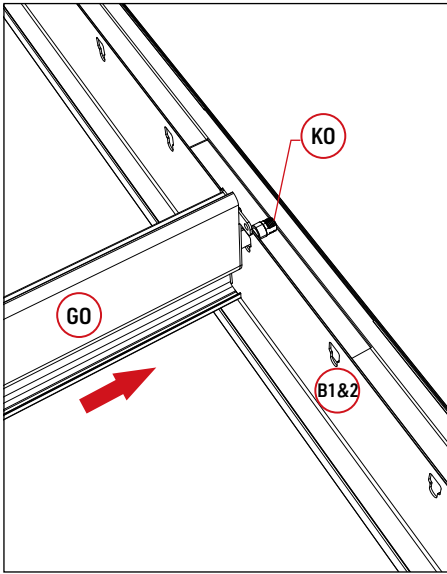

2

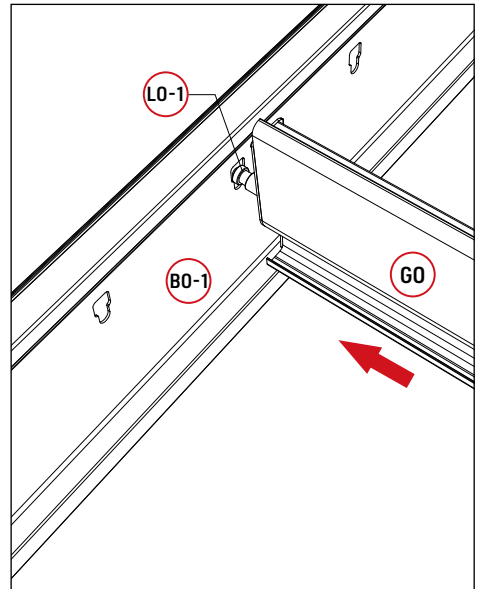
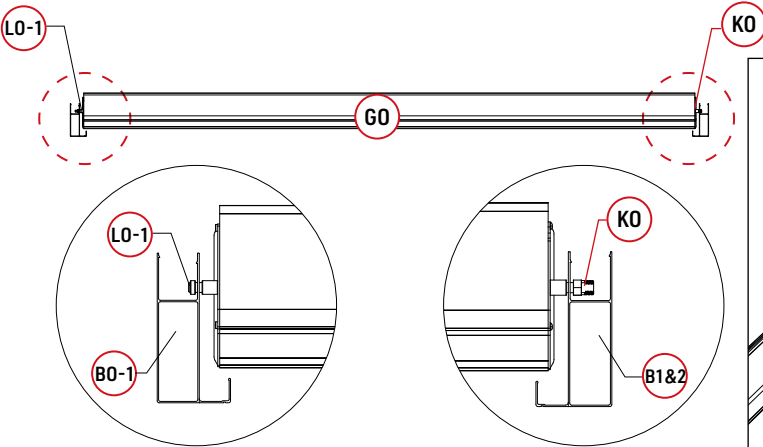

Step 3: Install louvers & Connection

3-2

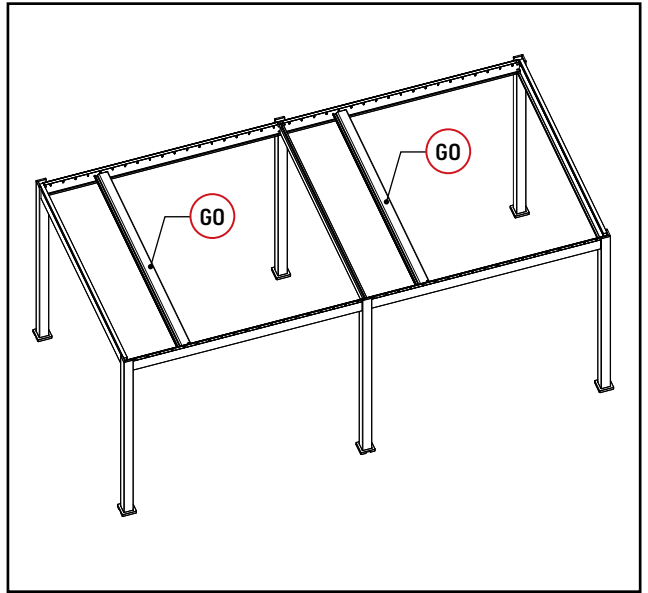

Make the louver flat, then connect the motor rocker arm to the spindle

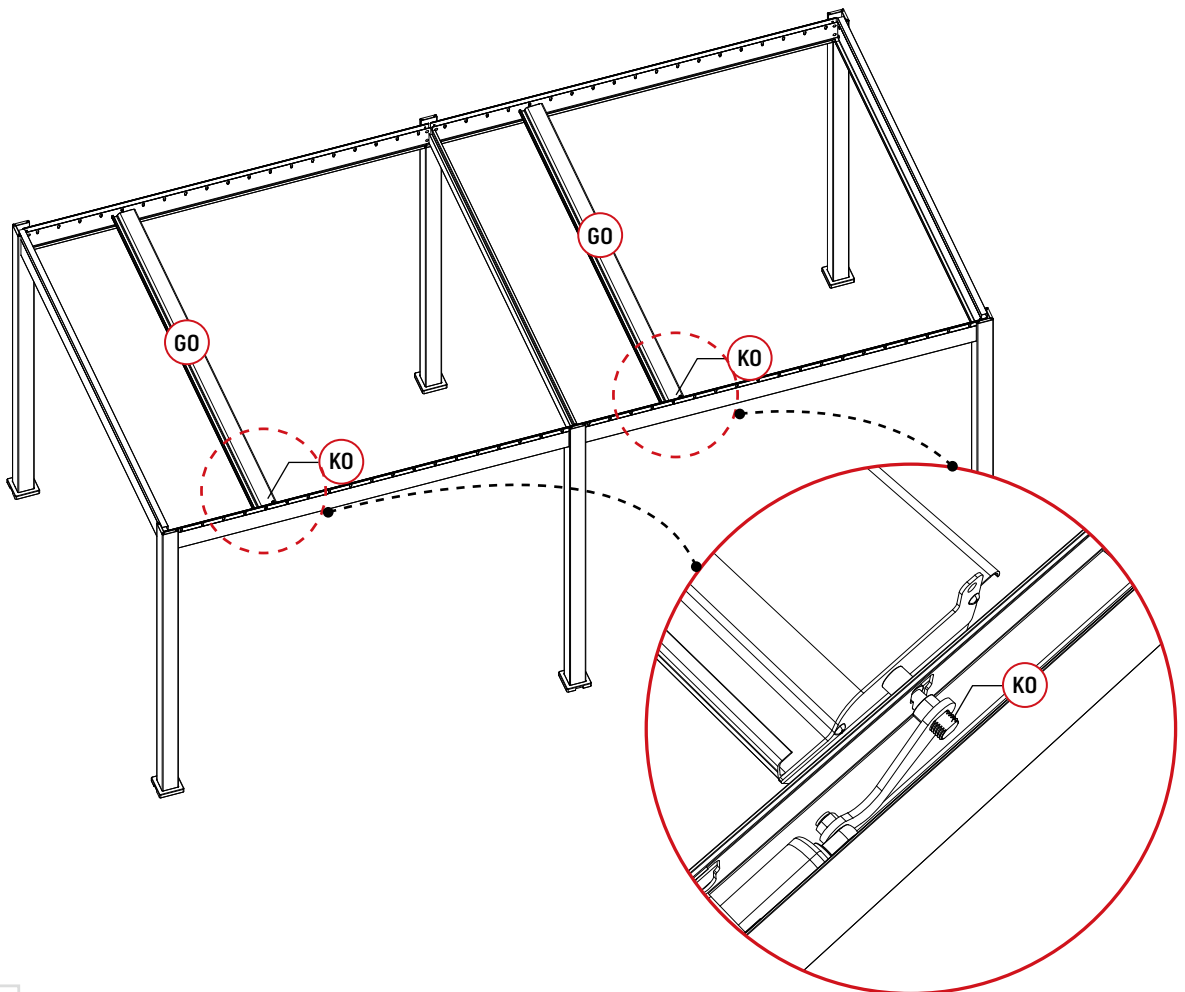

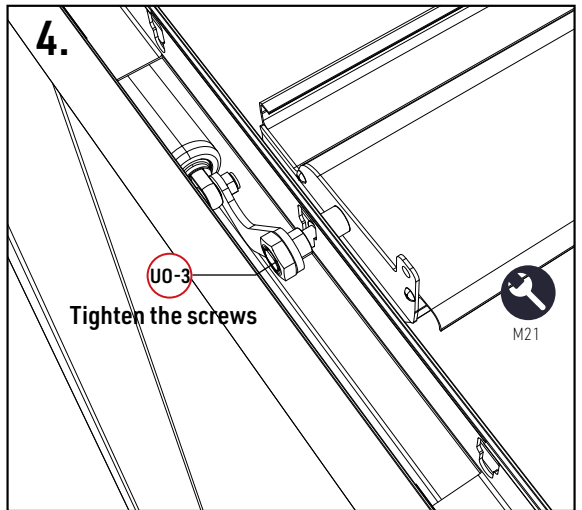
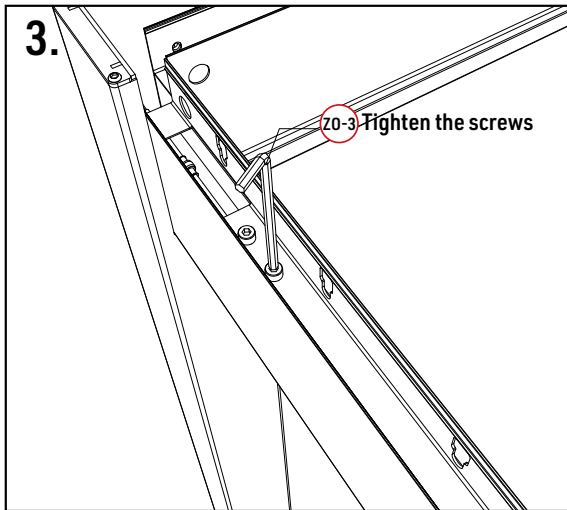
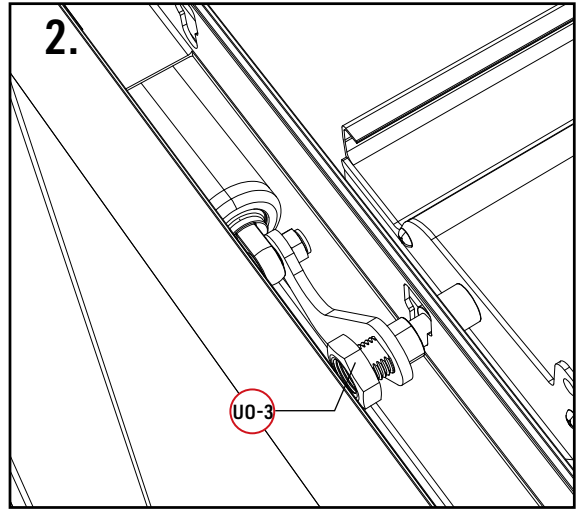
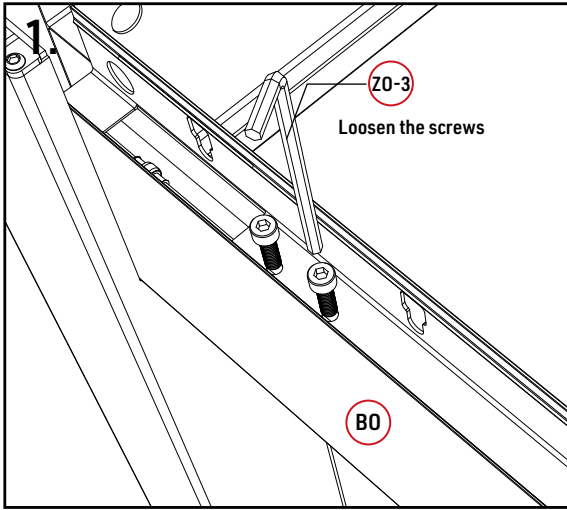

Step 3: Install louvers & Connection

3-3

E-R		1
-----	-----------------------------------------------------------------------------------	---

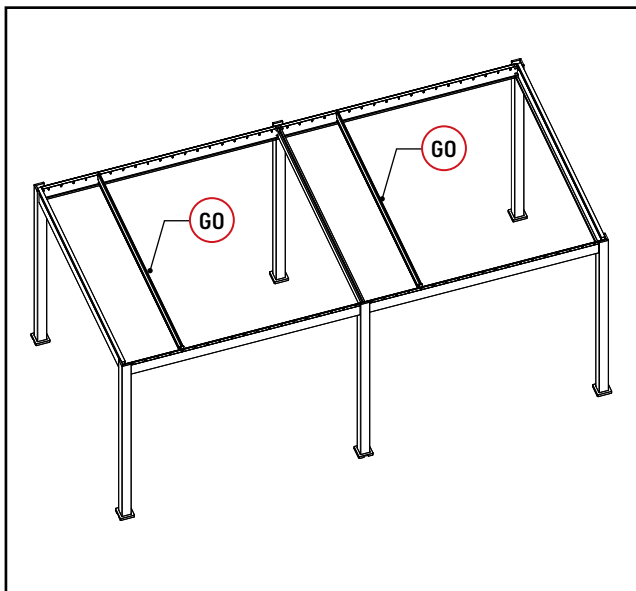

Motor Connection

1. Press the UP Button on the remote, hold this button for 3-5 seconds until the indicator becomes solid.
2. Plug in the power while press the UP button, when a slight vibration appears on the main louver, it means the remote and motor are paired.



Step1.

Press and hold for 3 seconds

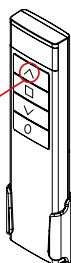

NTorch

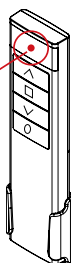

Step2.

Plug in the power

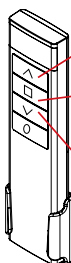
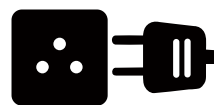

Up

Pause

Down

1. Check if the motor can work well, if not, please firstly check if the wiring in previous steps is correct.
2. When the motor works well, please rotate the main louvre to 90 degree, then install the rest louvres.

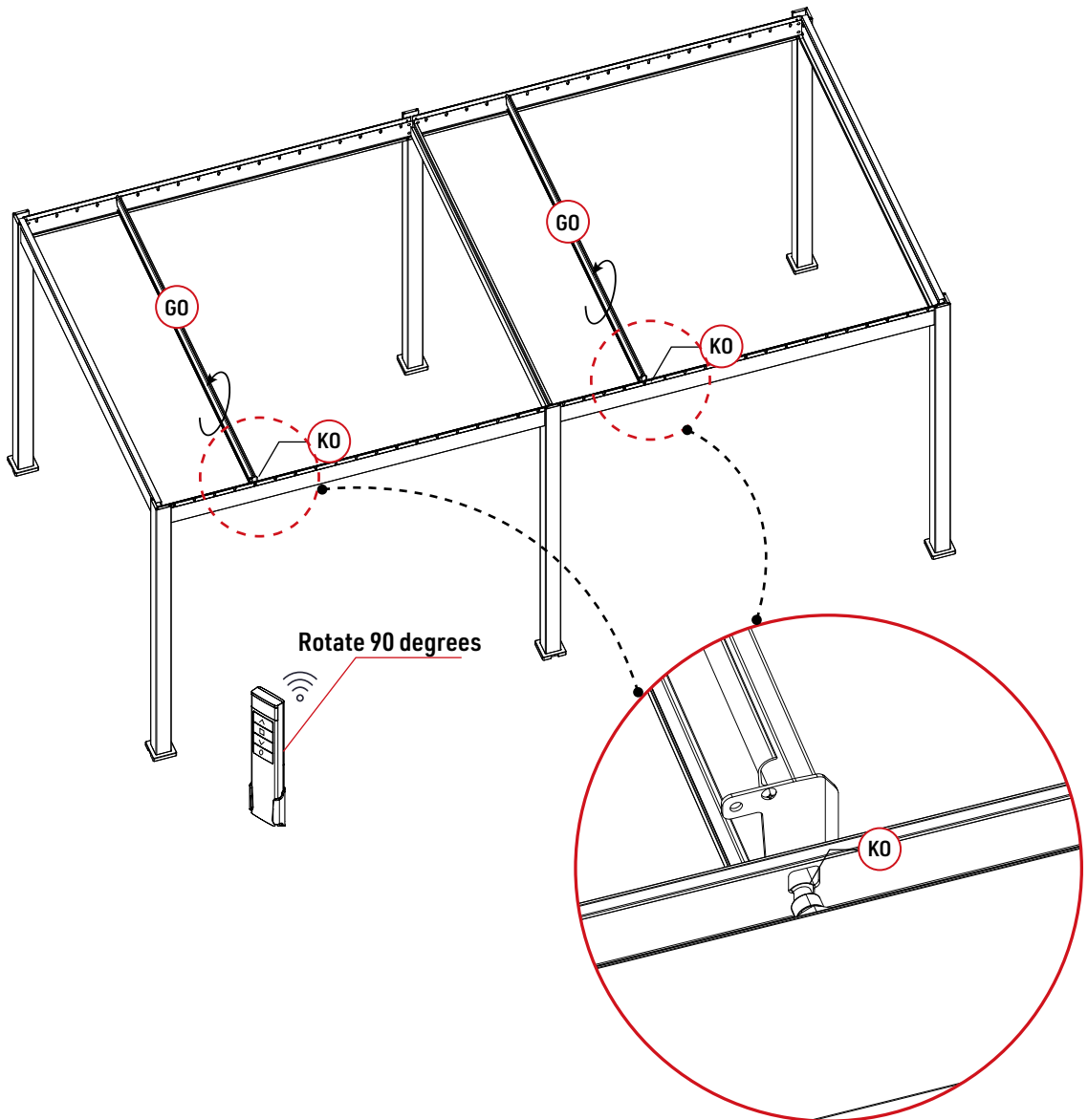

Step 3: Install louvers & Connection

3-4

Parts

S0		76
----	-----------------------------------------------------------------------------------	----

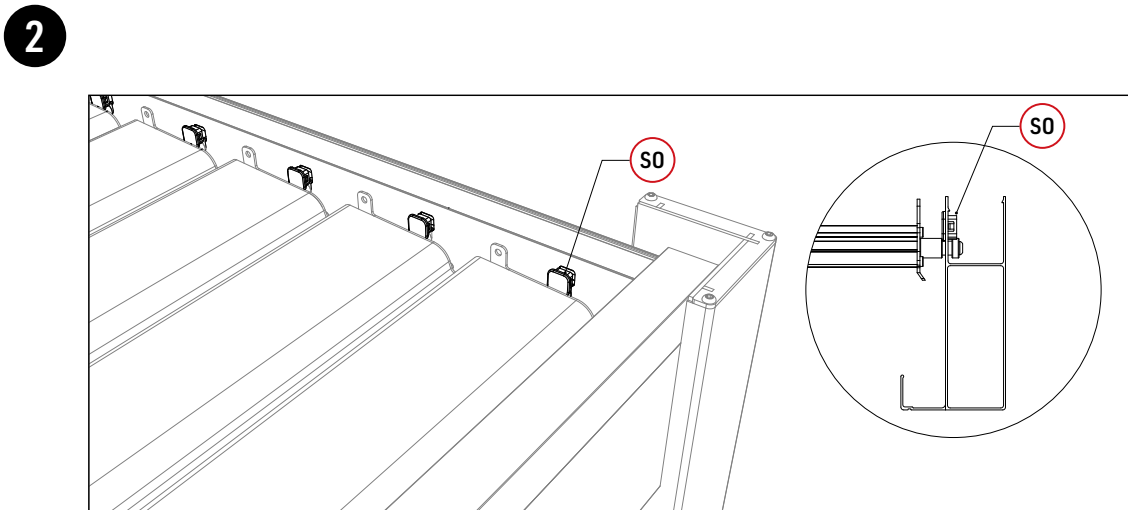
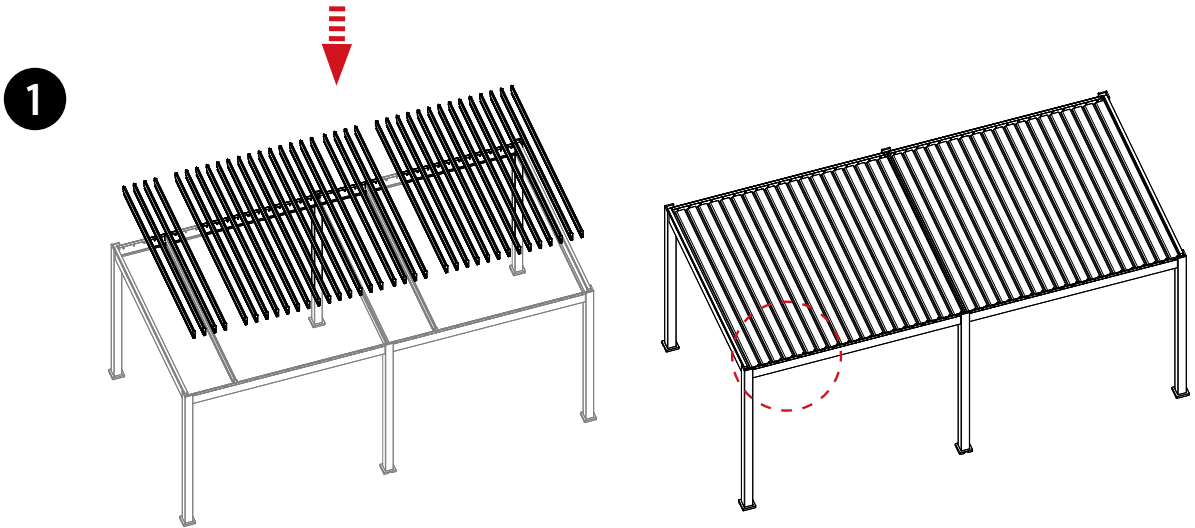

1. Install other louvers on the beam and make the louver flat
2. Cover the screw head with plastic caps



Step 3: Install louvers & Connection

3-5

Parts

F0		2
V0		38
U0	 lock nut	38

Tools

Z0-1	 4mm	1
Z0-2	 4mm	1
Z0-5	 10mm	1

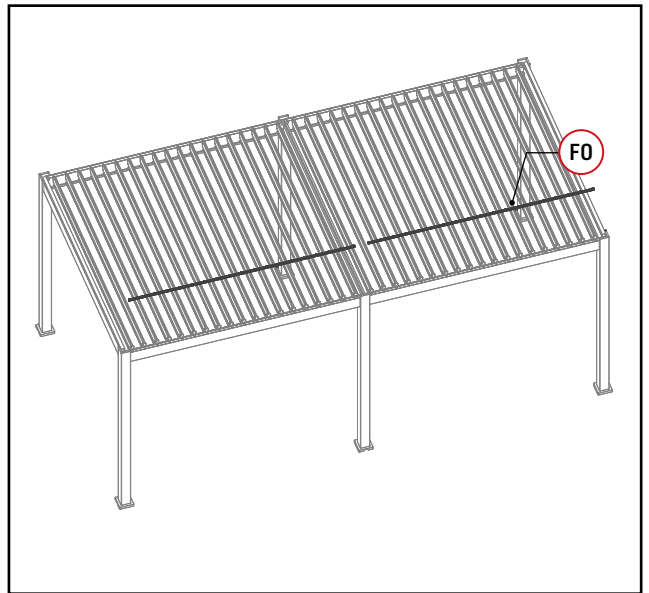



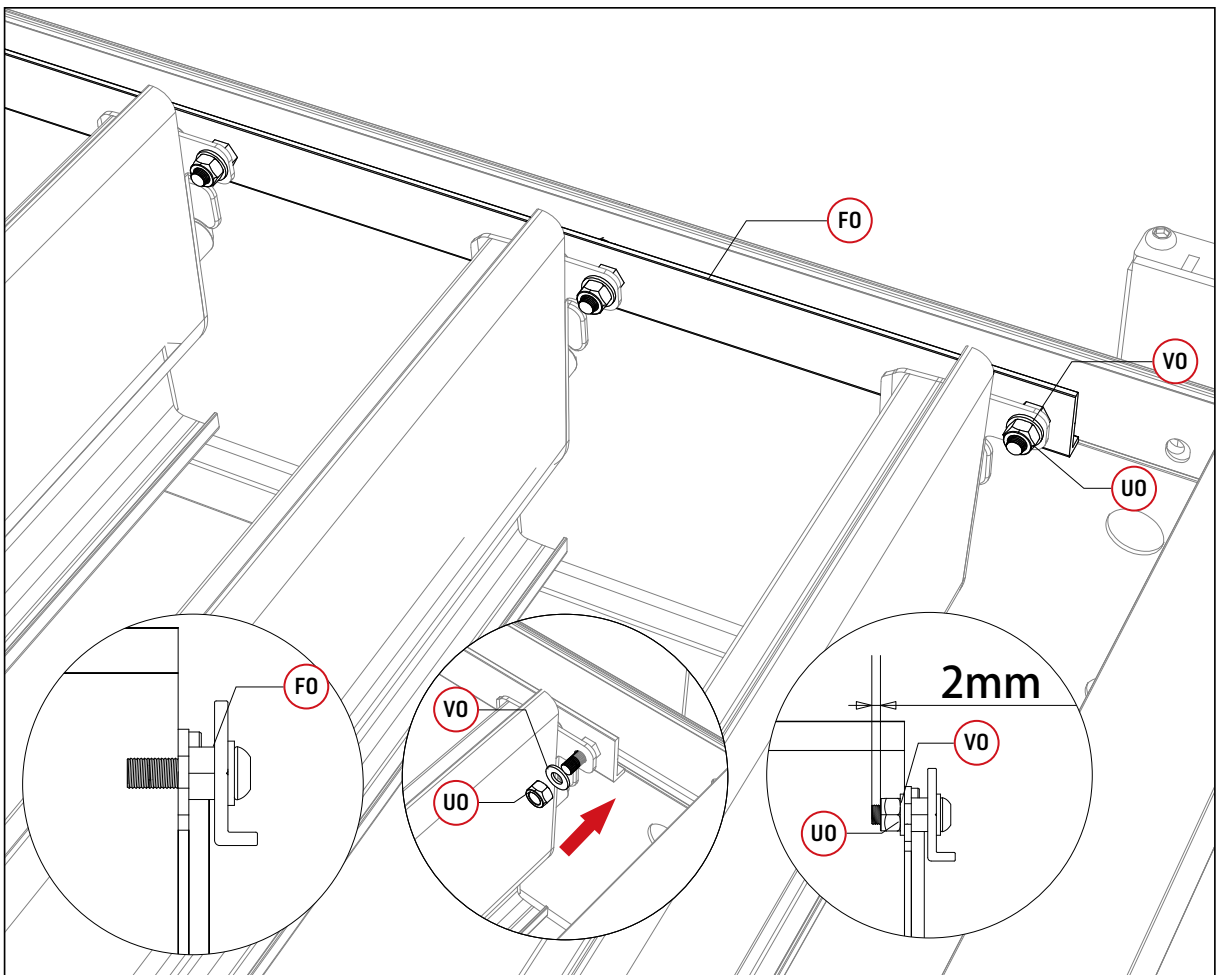

Install the connecting bar



Step 3: Install louvers & Connection

3-6

Parts

DO			4
RO			24
TO			24

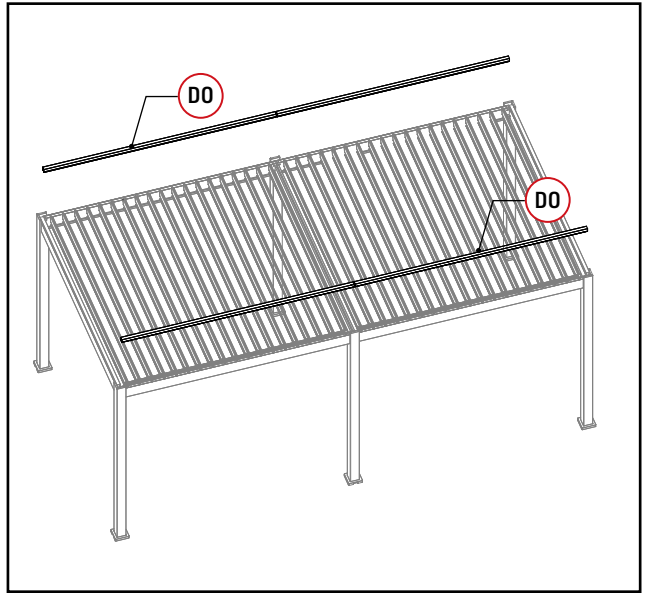

Cover the screw head with plastic caps

1

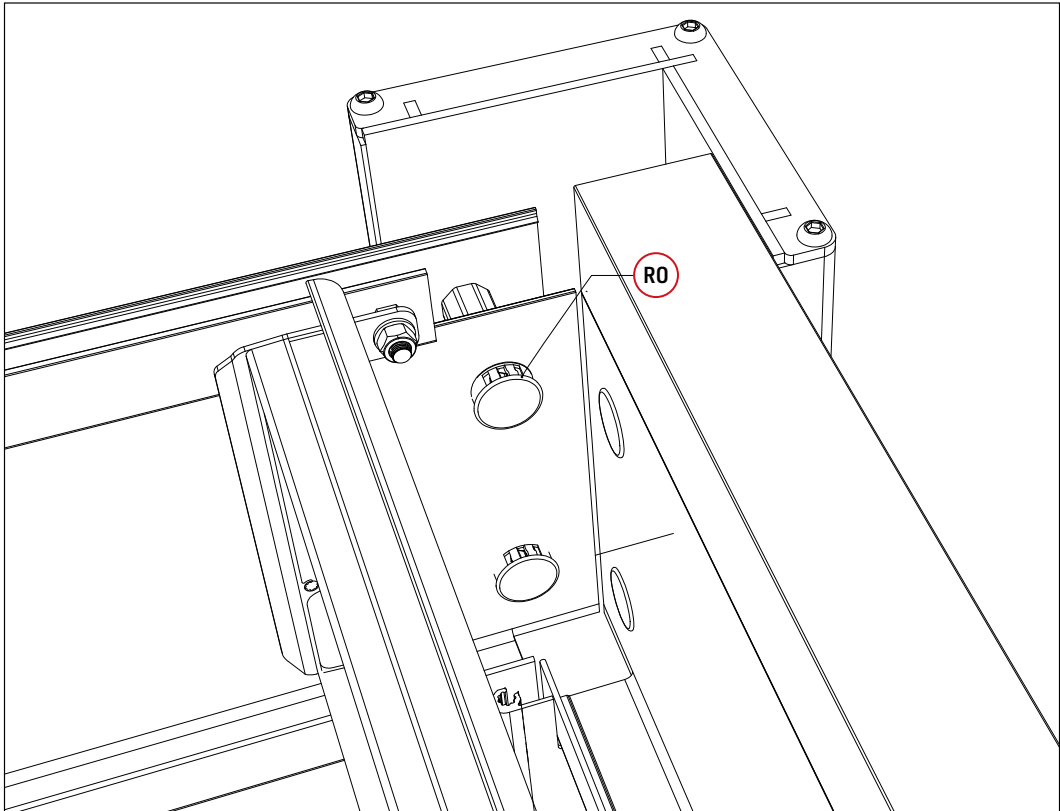

2

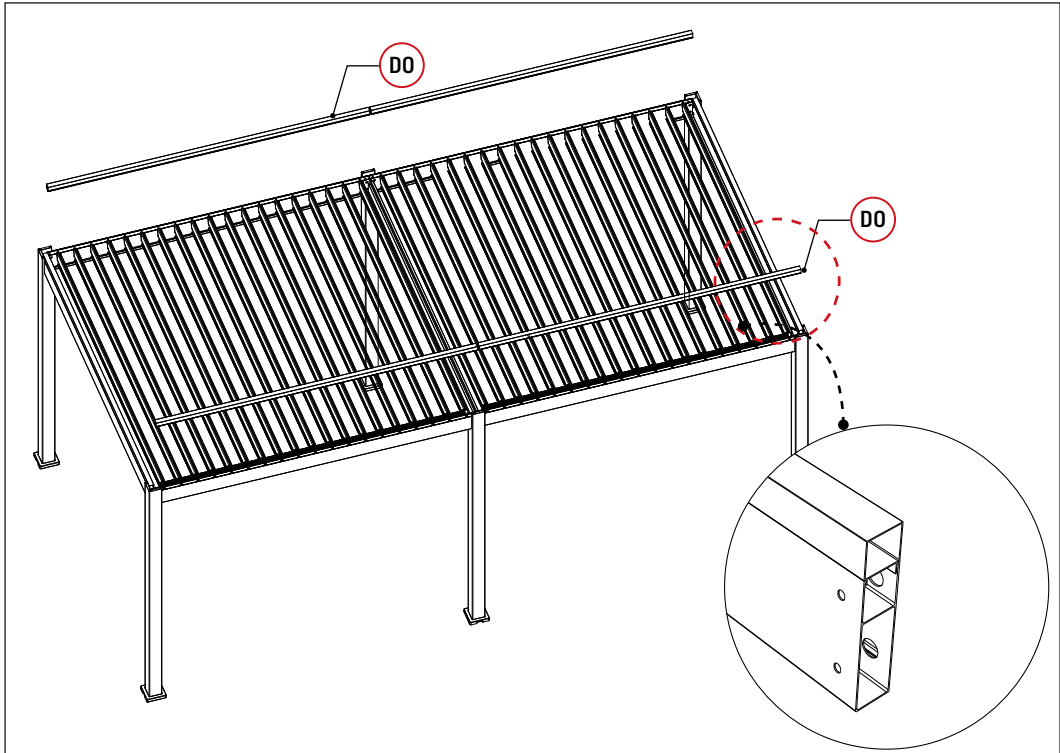

3

 Please check all footing dimension are correct, then fix all base plates.

